

SOLARMOUNT™

Code-Compliant Installation Manual 227.3

U.S. Des. Patent No. D496,248S, D496,249S. Other patents pending.



Unirac Code-Compliant Installation Manual

Table of Contents

i. Installer's Responsibilities	2
Part I. Procedure to Determine the Design Wind Load	3
Part II. Procedure to Select Rail Span and Rail Type	10
Part III. Installing SolarMount	
[3.1.] SolarMount rail components	14
[3.2.] Installing SolarMount with top mounting clamps	15
[3.3.] Installing SolarMount with bottom mounting clips	21
[3.4.] Installing SolarMount with grounding clips and lugs	25



Unirac welcomes input concerning the accuracy and user-friendliness of this publication. Please write to publications@unirac.com.

Pub 120220-1cc
February 2012

© 2012 by Unirac, Inc.
All rights reserved.

i. Installer's Responsibilities

Please review this manual thoroughly before installing your SolarMount system.

This manual provides (1) supporting documentation for building permit applications relating to Unirac's SolarMount Universal PV Module Mounting system, and (2) planning and assembly instructions for SolarMount

SolarMount products, when installed in accordance with this bulletin, will be structurally adequate and will meet the structural requirements of the IBC 2009, ASCE 7-05 and California Building Code 2010 (collectively referred to as "the Code"). Unirac also provides a limited warranty on SolarMount products (page 26).

SolarMount is much more than a product.

It's a system of engineered components that can be assembled into a wide variety of PV mounting structures. With SolarMount you'll be able to solve virtually any PV module mounting challenge.

It's also a system of technical support: complete installation and code compliance documentation, an on-line SolarMount Estimator, person-to-person customer service, and design assistance to help you solve the toughest challenges.

This is why SolarMount is PV's most widely used mounting system.



The installer is solely responsible for:

- Complying with all applicable local or national building codes, including any that may supersede this manual;
- Ensuring that Unirac and other products are appropriate for the particular installation and the installation environment;
- Ensuring that the roof, its rafters, connections, and other structural support members can support the array under all code level loading conditions (this total building assembly is referred to as the building structure);
- Using only Unirac parts and installer-supplied parts as specified by Unirac (substitution of parts may void the warranty and invalidate the letters of certification in all Unirac publications);
- Ensuring that lag screws have adequate pullout strength and shear capacities as installed;
- Verifying the strength of any alternate mounting used in lieu of the lag screws;
- Maintaining the waterproof integrity of the roof, including selection of appropriate flashing;
- Ensuring safe installation of all electrical aspects of the PV array;
- Ensuring correct and appropriate design parameters are used in determining the design loading used for design of the specific installation. Parameters, such as snow loading, wind speed, exposure and topographic factor should be confirmed with the local building official or a licensed professional engineer.

Part I. Procedure to Determine the Design Wind Load

[1.1.] Using the Simplified Method - ASCE 7-05

The procedure to determine Design Wind Load is specified by the American Society of Civil Engineers and referenced in the International Building Code 2009. For purposes of this document, the values, equations and procedures used in this document reference ASCE 7-05, Minimum Design Loads for Buildings and Other Structures. **Please refer to ASCE 7-05 if you have any questions about the definitions or procedures presented in this manual.** Unirac uses Method 1, the Simplified Method, for calculating the Design Wind Load for pressures on components and cladding in this document.

The method described in this document is valid for flush, no tilt, SolarMount Series applications on either roofs or walls. Flush is defined as panels parallel to the surface (or with no more than 3" difference between ends of assembly) with no more than 10" space between the roof surface, and the bottom of the PV panels.

This method is not approved for open structure calculations. **Applications of these procedures is subject to the following ASCE 7-05 limitations:**

1. The building height must be less than 60 feet, $h < 60$. See note for determining h in the next section. For installations on structures greater than 60 feet, contact your local Unirac Distributor.
2. The building must be enclosed, not an open or partially enclosed structure, for example a carport.
3. The building is regular shaped with no unusual geometrical irregularity in spatial form, for example a geodesic dome.
4. The building is not in an extreme geographic location such as a narrow canyon or steep cliff.
5. The building has a flat or gable roof with a pitch less than 45 degrees or a hip roof with a pitch less than 27 degrees.
6. If your installation does not conform to these requirements please contact your local Unirac distributor or a local professional engineer.

If your installation is outside the United States or does not meet all of these limitations, consult a local professional engineer or your local building authority. Consult ASCE 7-05

for more clarification on the use of Method I. Lower design wind loads may be obtained by applying Method II from ASCE 7-05. Consult with a licensed engineer if you want to use Method II procedures.

The equation for determining the Design Wind Load for components and cladding is:

$$p_{net} \text{ (psf)} = \lambda K_{zt} I p_{net30}$$

$p_{net} \text{ (psf)}$ = Design Wind Load

λ = adjustment factor for building height and exposure category

K_{zt} = Topographic Factor at mean roof height, h (ft)

I = Importance Factor

$p_{net30} \text{ (psf)}$ = net design wind pressure for Exposure B, at height = 30 feet, $I = 1.0$

You will also need to know the following information:

Basic Wind Speed = V (mph), the largest 3 second gust of wind in the last 50 years.

h (ft) = total roof height for flat roof buildings or mean roof height for pitched roof buildings

Roof Pitch (degrees)

This manual will help you determine:

Effective Wind Area (sf) = minimum total continuous area of modules being installed (Step 2)

Roof Zone = the area of the roof you are installing the pv system according to Step 3.

Roof Zone Dimension = a (ft) (Step 3)

Exposure Category (Step 6)

[1.2.] Procedure to Calculate Total Design Wind

The procedure for determining the Design Wind Load can be broken into steps that include looking up several values in different tables. Table 5 has been provided as a worksheet for the following 9 steps (page 8)

Step 1: Determine Basic Wind Speed, V (mph)

Determine the *Basic Wind Speed*, V (mph) by consulting your local building department or locating your installation on the maps in Figure 1, page 4.

Step 2: Determining Effective Wind Area

Determine the smallest area of continuous modules you will be installing. This is the smallest area tributary (contributing load) to a support or to a simple-span of rail. That area is the Effective Wind Area, the total area of the fewest number of modules on a run of rails. If the smallest area of continuous modules exceeds 100 sq ft, use 100 sq ft (See Table 2). If less, round down to values available in Table 2.

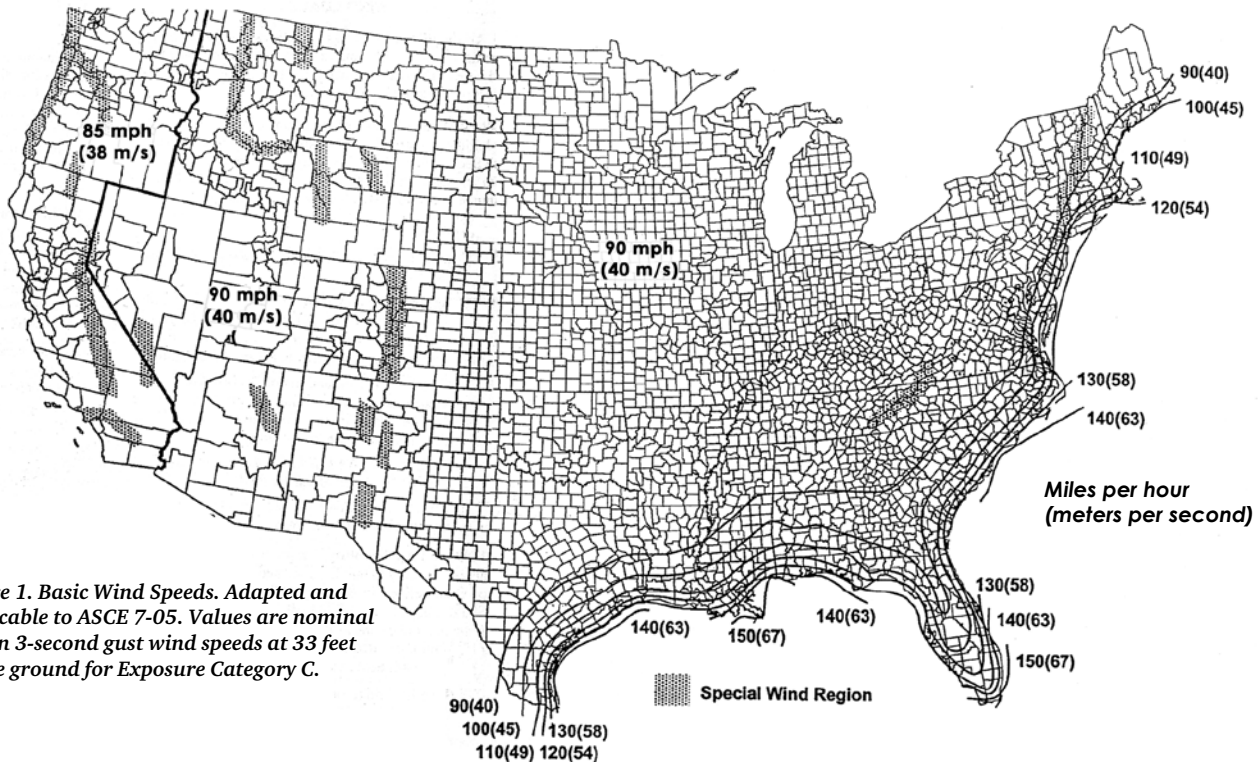

Figure 1. Basic Wind Speeds. Adapted and applicable to ASCE 7-05. Values are nominal design 3-second gust wind speeds at 33 feet above ground for Exposure Category C.

Step 3: Determine Roof/Wall Zone

The *Design Wind Load* will vary based on where the installation is located on a roof. Arrays may be located in more than one roof zone.

Using Table 1, determine the *Roof Zone Dimension Length, a (ft)*, according to the width and height of the building on which you are installing the pv system.

Table 1. Determine Roof/Wall Zone, dimension (a) according to building width and height

a = 10 percent of the least horizontal dimension or 0.4h, whichever is smaller, but not less than either 4% of the least horizontal dimension or 3 ft of the building.

Roof Height (ft)	Least Horizontal Dimension (ft)																		
	10	15	20	25	30	40	50	60	70	80	90	100	125	150	175	200	300	400	500
10	3	3	3	3	3	4	4	4	4	4	4	4	5	6	7	8	12	16	20
15	3	3	3	3	3	4	5	6	6	6	6	6	6	6	7	8	12	16	20
20	3	3	3	3	3	4	5	6	7	8	8	8	8	8	8	8	12	16	20
25	3	3	3	3	3	4	5	6	7	8	9	10	10	10	10	10	12	16	20
30	3	3	3	3	3	4	5	6	7	8	9	10	12	12	12	12	12	16	20
35	3	3	3	3	3	4	5	6	7	8	9	10	12.5	14	14	14	14	16	20
40	3	3	3	3	3	4	5	6	7	8	9	10	12.5	15	16	16	16	16	20
45	3	3	3	3	3	4	5	6	7	8	9	10	12.5	15	17.5	18	18	18	20
50	3	3	3	3	3	4	5	6	7	8	9	10	12.5	15	17.5	20	20	20	20
60	3	3	3	3	3	4	5	6	7	8	9	10	12.5	15	17.5	20	24	24	24

Source: ASCE/SEI 7-05, Minimum Design Loads for Buildings and Other Structures, Chapter 6, Figure 6-3, p. 41.

Step 3: Determine Roof Zone (continued)

Using *Roof Zone Dimension Length*, *a*, determine the roof zone locations according to your roof type, gable, hip or monoslope. Determine in which roof zone your pv system is located, Zone 1, 2, or 3 according to Figure 2.

Figure 2. Enclosed buildings, wall and roofs

Flat Roof

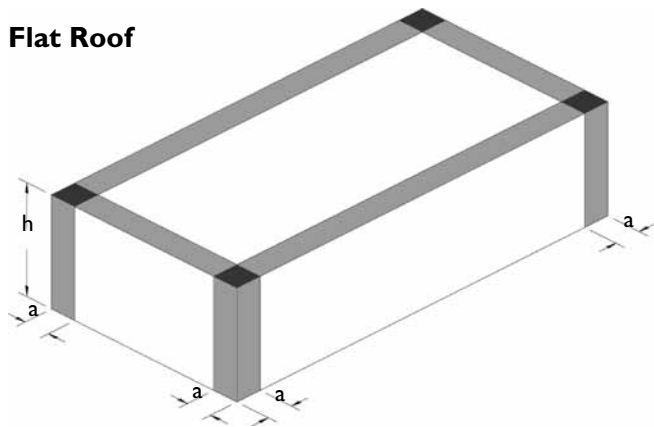

Hip Roof ($7^\circ < \theta \leq 27^\circ$)

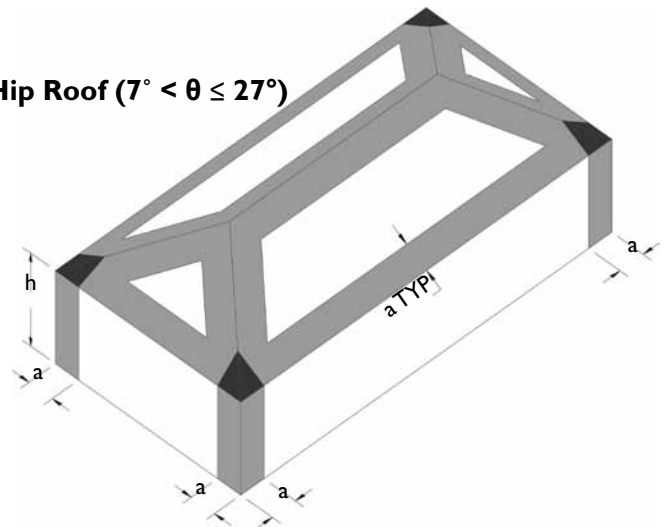

Gable Roof ($\theta \leq 7^\circ$)

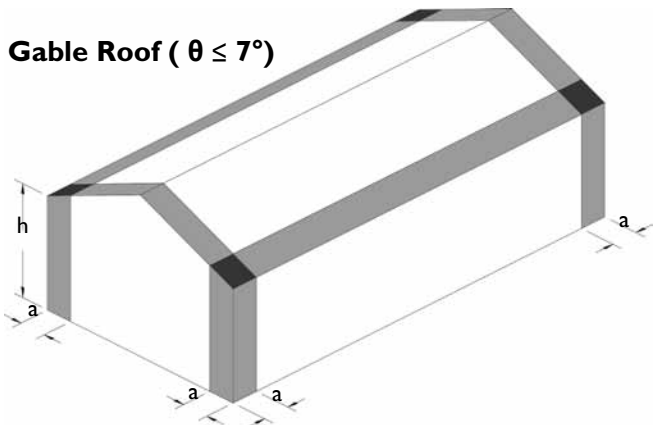

Gable Roof ($7^\circ < \theta \leq 45^\circ$)

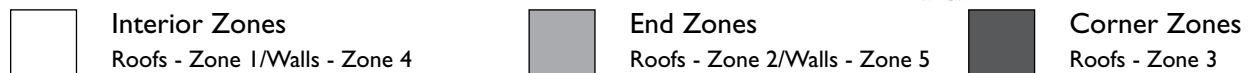
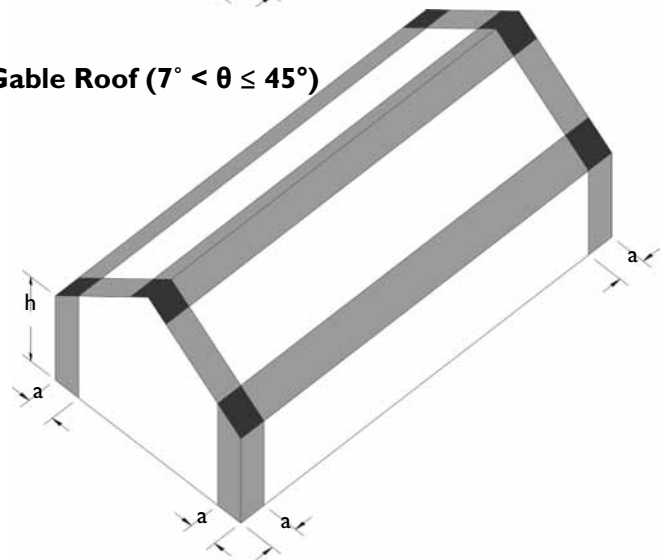

Source: ASCE/SEI 7-05, *Minimum Design Loads for Buildings and Other Structures*, Chapter 6, p. 41.

Step 4: Determine Net Design Wind Pressure, P_{net30} (psf)

Using the *Effective Wind Area* (Step 2), *Roof Zone Location* (Step 3), and *Basic Wind Speed* (Step 1), look up the appropriate *Net Design Wind Pressure* in Table 2, page 6. Use the *Effective Wind Area* value in the table which is smaller than the value calculated in Step 2. If the installation is located on a roof overhang, use Table 3, page 7.

Both downforce and uplift pressures must be considered in overall design. Refer to Section II, Step 1 for applying downforce and uplift pressures. Positive values are acting toward the surface. Negative values are acting away from the surface.

Table 2. p_{net30} (psf) Roof and Wall

		Basic Wind Speed, V (mph)																
Zone	Effective Wind Area (sf)	90		100		110		120		130		140		150		170		
		Downforce	Uplift	Downforce	Uplift	Downforce	Uplift	Downforce	Uplift	Downforce	Uplift	Downforce	Uplift	Downforce	Uplift	Downforce	Uplift	
Roof 0 to 7 degrees	1	10	5.9	-14.6	7.3	-18.0	8.9	-21.8	10.5	-25.9	12.4	-30.4	14.3	-35.3	16.5	-40.5	21.1	-52.0
		20	5.6	-14.2	6.9	-17.5	8.3	-21.2	9.9	-25.2	11.6	-29.6	13.4	-34.4	15.4	-39.4	19.8	-50.7
		50	5.1	-13.7	6.3	-16.9	7.6	-20.5	9.0	-24.4	10.6	-28.6	12.3	-33.2	14.1	-38.1	18.1	-48.9
		100	4.7	-13.3	5.8	-16.5	7.0	-19.9	8.3	-23.7	9.8	-27.8	11.4	-32.3	13.0	-37.0	16.7	-47.6
	2	10	5.9	-24.4	7.3	-30.2	8.9	-36.5	10.5	-43.5	12.4	-51.0	14.3	-59.2	16.5	-67.9	21.1	-87.2
		20	5.6	-21.8	6.9	-27.0	8.3	-32.6	9.9	-38.8	11.6	-45.6	13.4	-52.9	15.4	-60.7	19.8	-78.0
		50	5.1	-18.4	6.3	-22.7	7.6	-27.5	9.0	-32.7	10.6	-38.4	12.3	-44.5	14.1	-51.1	18.1	-65.7
		100	4.7	-15.8	5.8	-19.5	7.0	-23.6	8.3	-28.1	9.8	-33.0	11.4	-38.2	13.0	-43.9	16.7	-56.4
	3	10	5.9	-36.8	7.3	-45.4	8.9	-55.0	10.5	-65.4	12.4	-76.8	14.3	-89.0	16.5	-102.2	21.1	-131.3
		20	5.6	-30.5	6.9	-37.6	8.3	-45.5	9.9	-54.2	11.6	-63.6	13.4	-73.8	15.4	-84.7	19.8	-108.7
		50	5.1	-22.1	6.3	-27.3	7.6	-33.1	9.0	-39.3	10.6	-46.2	12.3	-53.5	14.1	-61.5	18.1	-78.9
		100	4.7	-15.8	5.8	-19.5	7.0	-23.6	8.3	-28.1	9.8	-33.0	11.4	-38.2	13.0	-43.9	16.7	-56.4
Roof > 7 to 27 degrees	1	10	8.4	-13.3	10.4	-16.5	12.5	-19.9	14.9	-23.7	17.5	-27.8	20.3	-32.3	23.3	-37.0	30.0	-47.6
		20	7.7	-13.0	9.4	-16.0	11.4	-19.4	13.6	-23.0	16.0	-27.0	18.5	-31.4	21.3	-36.0	27.3	-46.3
		50	6.7	-12.5	8.2	-15.4	10.0	-18.6	11.9	-22.2	13.9	-26.0	16.1	-30.2	18.5	-34.6	23.8	-44.5
		100	5.9	-12.1	7.3	-14.9	8.9	-18.1	10.5	-21.5	12.4	-25.2	14.3	-29.3	16.5	-33.6	21.1	-43.2
	2	10	8.4	-23.2	10.4	-28.7	12.5	-34.7	14.9	-41.3	17.5	-48.4	20.3	-56.2	23.3	-64.5	30.0	-82.8
		20	7.7	-21.4	9.4	-26.4	11.4	-31.9	13.6	-38.0	16.0	-44.6	18.5	-51.7	21.3	-59.3	27.3	-76.2
		50	6.7	-18.9	8.2	-23.3	10.0	-28.2	11.9	-33.6	13.9	-39.4	16.1	-45.7	18.5	-52.5	23.8	-67.4
		100	5.9	-17.0	7.3	-21.0	8.9	-25.5	10.5	-30.3	12.4	-35.6	14.3	-41.2	16.5	-47.3	21.1	-60.8
	3	10	8.4	-34.3	10.4	-42.4	12.5	-51.3	14.9	-61.0	17.5	-71.6	20.3	-83.1	23.3	-95.4	30.0	-122.5
		20	7.7	-32.1	9.4	-39.6	11.4	-47.9	13.6	-57.1	16.0	-67.0	18.5	-77.7	21.3	-89.2	27.3	-114.5
		50	6.7	-29.1	8.2	-36.0	10.0	-43.5	11.9	-51.8	13.9	-60.8	16.1	-70.5	18.5	-81.0	23.8	-104.0
		100	5.9	-26.9	7.3	-33.2	8.9	-40.2	10.5	-47.9	12.4	-56.2	14.3	-65.1	16.5	-74.8	21.1	-96.0
Roof > 27 to 45 degrees	1	10	13.3	-14.6	16.5	-18.0	19.9	-21.8	23.7	-25.9	27.8	-30.4	32.3	-35.3	37.0	-40.5	47.6	-52.0
		20	13.0	-13.8	16.0	-17.1	19.4	-20.7	23.0	-24.6	27.0	-28.9	31.4	-33.5	36.0	-38.4	46.3	-49.3
		50	12.5	-12.8	15.4	-15.9	18.6	-19.2	22.2	-22.8	26.0	-26.8	30.2	-31.1	34.6	-35.7	44.5	-45.8
		100	12.1	-12.1	14.9	-14.9	18.1	-18.1	21.5	-21.5	25.2	-25.2	29.3	-29.3	33.6	-33.6	43.2	-43.2
	2	10	13.3	-17.0	16.5	-21.0	19.9	-25.5	23.7	-30.3	27.8	-35.6	32.3	-41.2	37.0	-47.3	47.6	-60.8
		20	13.0	-16.3	16.0	-20.1	19.4	-24.3	23.0	-29.0	27.0	-34.0	31.4	-39.4	36.0	-45.3	46.3	-58.1
		50	12.5	-15.3	15.4	-18.9	18.6	-22.9	22.2	-27.2	26.0	-32.0	30.2	-37.1	34.6	-42.5	44.5	-54.6
		100	12.1	-14.6	14.9	-18.0	18.1	-21.8	21.5	-25.9	25.2	-30.4	29.3	-35.3	33.6	-40.5	43.2	-52.0
	3	10	13.3	-17.0	16.5	-21.0	19.9	-25.5	23.7	-30.3	27.8	-35.6	32.3	-41.2	37.0	-47.3	47.6	-60.8
		20	13.0	-16.3	16.0	-20.1	19.4	-24.3	23.0	-29.0	27.0	-34.0	31.4	-39.4	36.0	-45.3	46.3	-58.1
		50	12.5	-15.3	15.4	-18.9	18.6	-22.9	22.2	-27.2	26.0	-32.0	30.2	-37.1	34.6	-42.5	44.5	-54.6
		100	12.1	-14.6	14.9	-18.0	18.1	-21.8	21.5	-25.9	25.2	-30.4	29.3	-35.3	33.6	-40.5	43.2	-52.0
Wall	4	10	14.6	-15.8	18.0	-19.5	21.8	-23.6	25.9	-28.1	30.4	-33.0	35.3	-38.2	40.5	-43.9	52.0	-56.4
		20	13.9	-15.1	17.2	-18.7	20.8	-22.6	24.7	-26.9	29.0	-31.6	33.7	-36.7	38.7	-42.1	49.6	-54.1
		50	13.0	-14.3	16.1	-17.6	19.5	-21.3	23.2	-25.4	27.2	-29.8	31.6	-34.6	36.2	-39.7	46.6	-51.0
		100	12.4	-13.6	15.3	-16.8	18.5	-20.4	22.0	-24.2	25.9	-28.4	30.0	-33.0	34.4	-37.8	44.2	-48.6
	5	10	14.6	-19.5	18.0	-24.1	21.8	-29.1	25.9	-34.7	30.4	-40.7	35.3	-47.2	40.5	-54.2	52.0	-69.6
		20	13.9	-18.2	17.2	-22.5	20.8	-27.2	24.7	-32.4	29.0	-38.0	33.7	-44.0	38.7	-50.5	49.6	-64.9
		50	13.0	-16.5	16.1	-20.3	19.5	-24.6	23.2	-29.3	27.2	-34.3	31.6	-39.8	36.2	-45.7	46.6	-58.7
		100	12.4	-15.1	15.3	-18.7	18.5	-22.6	22.0	-26.9	25.9	-31.6	30.0	-36.7	34.4	-42.1	44.2	-54.1
	5	500	10.9	-12.1	13.4	-14.9	16.2	-18.1	19.3	-21.5	22.7	-25.2	26.3	-29.3	30.2	-33.6	38.8	-43.2
		10	14.6	-19.5	18.0	-24.1	21.8	-29.1	25.9	-34.7	30.4	-40.7	35.3	-47.2	40.5	-54.2	52.0	-69.6
		20	13.9	-18.2	17.2	-22.5	20.8	-27.2	24.7	-32.4	29.0	-38.0	33.7	-44.0	38.7	-50.5	49.6	-64.9
		50	13.0	-16.5	16.1	-20.3	19.5	-24.6	23.2	-29.3	27.2	-34.3	31.6	-39.8	36.2	-45.7	46.6	-58.7
5	100	12.4	-15.1	15.3	-18.7	18.5	-22.6	22.0	-26.9	25.9	-31.6	30.0	-36.7	34.4	-42.1	44.2	-54.1	
	500	10.9	-12.1	13.4	-14.9	16.2	-18.1	19.3	-21.5	22.7	-25.2	26.3	-29.3	30.2	-33.6	38.8	-43.2	

Source: ASCE/SEI 7-05, Minimum Design Loads for Buildings and Other Structures, Chapter 6, Figure 6-3, p. 42-43.

Table 3. p_{net30} (psf) Roof Overhang

	Zone	Effective Wind Area (sf)	Basic Wind Speed, V (mph)							
			90	100	110	120	130	140	150	170
Roof 0 to 7 degrees	2	10	-21.0	-25.9	-31.4	-37.3	-43.8	-50.8	-58.3	-74.9
	2	20	-20.6	-25.5	-30.8	-36.7	-43.0	-49.9	-57.3	-73.6
	2	50	-20.1	-24.9	-30.1	-35.8	-42.0	-48.7	-55.9	-71.8
	2	100	-19.8	-24.4	-29.5	-35.1	-41.2	-47.8	-54.9	-70.5
	3	10	-34.6	-42.7	-51.6	-61.5	-72.1	-83.7	-96.0	-123.4
	3	20	-27.1	-33.5	-40.5	-48.3	-56.6	-65.7	-75.4	-96.8
	3	50	-17.3	-21.4	-25.9	-30.8	-36.1	-41.9	-48.1	-61.8
	3	100	-10.0	-12.2	-14.8	-17.6	-20.6	-23.9	-27.4	-35.2
Roof >7 to 27 degrees	2	10	-27.2	-33.5	-40.6	-48.3	-56.7	-65.7	-75.5	-96.9
	2	20	-27.2	-33.5	-40.6	-48.3	-56.7	-65.7	-75.5	-96.9
	2	50	-27.2	-33.5	-40.6	-48.3	-56.7	-65.7	-75.5	-96.9
	2	100	-27.2	-33.5	-40.6	-48.3	-56.7	-65.7	-75.5	-96.9
	3	10	-45.7	-56.4	-68.3	-81.2	-95.3	-110.6	-126.9	-163.0
	3	20	-41.2	-50.9	-61.6	-73.3	-86.0	-99.8	-114.5	-147.1
	3	50	-35.3	-43.6	-52.8	-62.8	-73.7	-85.5	-98.1	-126.1
	3	100	-30.9	-38.1	-46.1	-54.9	-64.4	-74.7	-85.8	-110.1
Roof >27 to 45 degrees	2	10	-24.7	-30.5	-36.9	-43.9	-51.5	-59.8	-68.6	-88.1
	2	20	-24.0	-29.6	-35.8	-42.6	-50.0	-58.0	-66.5	-85.5
	2	50	-23.0	-28.4	-34.3	-40.8	-47.9	-55.6	-63.8	-82.0
	2	100	-22.2	-27.4	-33.2	-39.5	-46.4	-53.8	-61.7	-79.3
	3	10	-24.7	-30.5	-36.9	-43.9	-51.5	-59.8	-68.6	-88.1
	3	20	-24.0	-29.6	-35.8	-42.6	-50.0	-58.0	-66.5	-85.5
	3	50	-23.0	-28.4	-34.3	-40.8	-47.9	-55.6	-63.8	-82.0
	3	100	-22.2	-27.4	-33.2	-39.5	-46.4	-53.8	-61.7	-79.3

Source: ASCE/SEI 7-05, *Minimum Design Loads for Buildings and Other Structures*, Chapter 6, p. 44.

Step 5: Determine the Topographic Factor, K_{zt}

For the purposes of this code compliance document, the *Topographic Factor*, K_{zt} , is taken as equal to one (1), meaning, the installation is surrounded by level ground (less than 10% slope). If the installation is not surrounded by level ground, please consult ASCE 7-05, Section 6.5.7 and the local building authority to determine the *Topographic Factor*.

Step 6: Determine Exposure Category (B, C, D)

Determine the *Exposure Category* by using the following definitions for Surface Roughness Categories.

The ASCE/SEI 7-05 defines wind surface roughness categories as follows:

SURFACE ROUGHNESS B: is urban and suburban areas, wooded areas, or other terrain with numerous closely spaced obstructions having the size of single family dwellings.

SURFACE ROUGHNESS C: has open terrain with scattered obstructions having heights generally less than 30 feet. This category includes flat open country, grasslands, and all water surfaces in hurricane prone regions.

SURFACE ROUGHNESS D: has flat, unobstructed areas and water surfaces outside hurricane prone regions. This category includes smooth mud flats, salt flats, and unbroken ice.

Also see ASCE 7-05 pages 287-291 for further explanation and explanatory photographs, and confirm your selection with the local building authority.

Step 7: Determine adjustment factor for height and exposure category, λ

Using the *Exposure Category* (Step 6) and the *roof height, h (ft)*, look up the *adjustment factor for height and exposure* in **Table 4**.

Step 8: Determine the Importance Factor, I

Determine if the installation is in a hurricane prone region. Look up the *Importance Factor, I*, Table 6, page 9, using the occupancy category description and the hurricane prone region status.

Step 9: Calculate the Design Wind Load, p_{net} (psf)

Multiply the *Net Design Wind Pressure, p_{net30} (psf)* (Step 4) by the *adjustment factor for height and exposure, λ* (Step 7), the *Topographic Factor, K_{zt}* (Step 5), and the *Importance Factor, I* (Step 8) using the following equation, or Table 5 Worksheet.

$$p_{net} (psf) = \lambda K_{zt} I p_{net30}$$

p_{net} (psf) = Design Wind Load (10 psf minimum)

λ = adjustment factor for height and exposure category (Step 7)

K_{zt} = Topographic Factor at mean roof height, h (ft) (Step 5)

I = Importance Factor (Step 8)

p_{net30} (psf) = net design wind pressure for Exposure B, at height = 30, I = 1 (Step 4)

Use **Table 5** below to calculate Design Wind Load.

The Design Wind Load will be used in **Part II** to select the appropriate SolarMount Series rail, rail span and foot spacing.

In **Part II**, use both the positive (downforce) and the negative (uplift) results from this calculation.

Table 4. Adjustment Factor (λ) for Roof Height & Exposure Category

Mean roof height (ft)	Exposure		
	B	C	D
15	1.00	1.21	1.47
20	1.00	1.29	1.55
25	1.00	1.35	1.61
30	1.00	1.40	1.66
35	1.05	1.45	1.70
40	1.09	1.49	1.74
45	1.12	1.53	1.78
50	1.16	1.56	1.81
55	1.19	1.59	1.84
60	1.22	1.62	1.87

Source: ASCE/SEI 7-05, Minimum Design Loads for Buildings and Other Structures, Chapter 6, Figure 6-3, p. 44.

Table 5. Worksheet for Components and Cladding Wind Load Calculation: IBC 2009, ASCE 7-05

Variable Description	Symbol	Value	Unit	Step	Reference
Building Height	h		ft		
Building, Least Horizontal Dimension			ft		
Roof Pitch			degrees		
Exposure Category				6	
Basic Wind Speed	V		mph	1	Figure 1
Effective Wind Area			sf		
Roof Zone Setback Length	a		ft	2	
Roof Zone Location				3	Table 1
Roof Zone Location				3	Figure 2
Net Design Wind Pressure	p_{net30}		psf	4	Table 2, 3
Topographic Factor	K_{zt}	x		5	
Adjustment factor for height and exposure category	λ	x		7	Table 4
Importance Factor	I	x		8	Table 5
Total Design Wind Load	p_{net}		psf	9	

Table 6. Occupancy Category Importance Factor

Category	Category Description	Building Type Examples	Non-Hurricane Prone Regions and Hurricane Prone Regions with Basic Wind Speed, $V = 85-100$ mph, and Alaska	Hurricane Prone Regions with Basic Wind Speed, $V > 100$ mph
I	Buildings and other structures that represent a low hazard to human life in the event of failure, including, but limited to:	<ul style="list-style-type: none"> • Agricultural facilities • Certain Temporary facilities • Minor Storage facilities 	0.87	0.77
II	All buildings and other structures except those listed in Occupancy Categories I, III, and IV.		I	I
III	Buildings and other structures that represent a substantial hazard to human life in the event of a failure, including, but not limited to:	<ul style="list-style-type: none"> • Buildings where more than 300 people congregate • Schools with a capacity more than 250 • Day Cares with a capacity more than 150 • Buildings for colleges with a capacity more than 500 • Health Care facilities with a capacity more than 50 or more resident patients • Jails and Detention Facilities • Power Generating Stations • Water and Sewage Treatment Facilities • Telecommunication Centers • Buildings that manufacture or house hazardous materials 	1.15	1.15
IV	Buildings and other structures designated as essential facilities, including, but not limited to:	<ul style="list-style-type: none"> • Hospitals and other health care facilities having surgery or emergency treatment • Fire, rescue, ambulance and police stations • Designated earthquake, hurricane, or other emergency shelters • Designated emergency preparedness communication, and operation centers • Power generating stations and other public utility facilities required in an emergency • Ancillary structures required for operation of Occupancy Category IV structures • Aviation control towers, air traffic control centers, and emergency aircraft hangars • Water storage facilities and pump structures required to maintain water pressure for fire suppression • Buildings and other structures having critical national defense functions 	1.15	1.15

Source: IBC 2009, Table 1604.5, Occupancy Category of Buildings and other structures, p. 281; ASCE/SEI 7-05, Minimum Design Loads for Buildings and Other Structures, Table 6-1, p. 77

Part II. Procedure to Select Rail Span and Rail Type

[2.1.] Using Standard Beam Calculations, Structural Engineering Methodology

The procedure to determine the Unirac SolarMount series rail type and rail span uses standard beam calculations and structural engineering methodology. The beam calculations are based on a simply supported beam conservatively, ignoring the reductions allowed for supports of continuous beams over multiple supports. Please refer to **Part I** for more information on beam calculations, equations and assumptions. If beams are installed perpendicular to the eaves on a roof steeper than a 4/12 pitch in an area with a ground snow load greater than 30psf, then additional analysis is required for side loading on the roof attachment and beam.

In using this document, obtaining correct results is dependent upon the following:

1. Obtain the *Snow Load* for your area from your local building official.
2. Obtain the *Design Wind Load, p_{net}*. See **Part I** (Procedure to Determine the Design Wind Load) for more information on calculating the *Design Wind Load*.
3. **Please Note:** The terms rail span and footing spacing are interchangeable in this document. See **Figure 3** for illustrations.
4. To use **Table 8**, the *Dead Load* for your specific installation must be less than 5 psf, including modules and Unirac racking systems. If the *Dead Load* is greater than 5 psf, see your Unirac distributor, a local structural engineer or contact Unirac.

The following procedure will guide you in selecting a Unirac rail for a flush mount installation. It will also help determine the design loading imposed by the Unirac PV Mounting Assembly that the building structure must be capable of supporting.

Step 1: Determine the Total Design Load

Figure 3. Rail span and footing spacing are interchangeable.

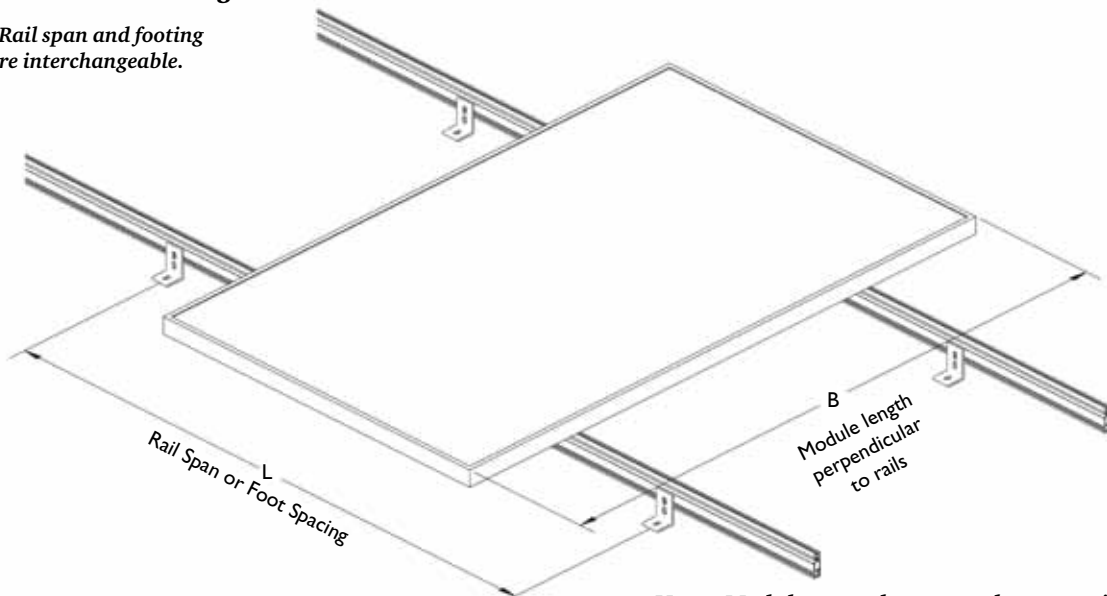

Note: Modules must be centered symmetrically on the rails (+/- 2*), as shown in Figure 3.

The *Total Design Load, P (psf)* is determined using ASCE 7-05 2.4.1 (ASD Method equations 3,5,6 and 7) by adding the *Snow Load¹, S (psf)*, *Design Wind Load, p_{net} (psf)* from **Part I, Step 9** and the *Dead Load (psf)*. Both Uplift and Downforce Wind Loads calculated in **Step 9 of Part 1** must be investigated. Use **Table 7** to calculate the Total Design Load for the load cases. Use the maximum absolute value of the three downforce cases and the uplift case for sizing the rail. Use the uplift case only for sizing lag bolts pull out capacities (**Part II, Step 6**). Use the following equations or **Table 7**.

$$P (psf) = 1.0D + 1.0S^1 \text{ (downforce case 1)}$$

$$P (psf) = 1.0D + 1.0p_{net} \text{ (downforce case 2)}$$

$$P (psf) = 1.0D + 0.75S^1 + 0.75p_{net} \text{ (downforce case 3)}$$

$$P (psf) = 0.6D + 1.0p_{net} \text{ (uplift)}$$

$$D = \text{Dead Load (psf)}$$

$$S = \text{Snow Load (psf)}$$

$$p_{net} = \text{Design Wind Load (psf) (Positive for downforce, negative for uplift)}$$

The maximum Dead Load, D (psf), is 5 psf based on market research and internal data.

¹ *Snow Load Reduction* - The snow load can be reduced according to Chapter 7 of ASCE 7-05. The reduction is a function of the roof slope, Exposure Factor, Importance Factor and Thermal Factor. Please refer to Chapter 7 of ASCE 7-05 for more information.

Table 7. ASCE 7 ASD Load Combinations

Description	Variable	Downforce Case 1	Downforce Case 2	Downforce Case 3	Uplift	units
Dead Load	D	1.0 x	1.0 x	1.0 x	0.6 x	psf
Snow Load	S	1.0 x + _____		0.75 x + _____		psf
Design Wind Load	Pnet		1.0 x + _____	0.75 x + _____	1.0 x -	psf
Total Design Load	P					psf

Note: Table to be filled out or attached for evaluation.

Step 2: Determine the Distributed Load on the rail, *w* (plf)

Determine the *Distributed Load, w (plf)*, by multiplying the module length, *B* (ft), by the *Total Design Load, P (psf)* and dividing by two. Use the maximum absolute value of the three downforce cases and the Uplift Case. We assume each module is supported by two rails.

$$w = PB/2$$

w = Distributed Load (pounds per linear foot, plf)

B = Module Length Perpendicular to Rails (ft)

P = Total Design Pressure (pounds per square foot, psf)

Step 3: Determine Rail Span/ L-Foot Spacing

Using the *distributed load, w*, from Part II, **Step 2**, look up the *allowable spans, L*, for each Unirac rail type, SolarMount (SM) and SolarMount Heavy Duty (HD).

The L-Foot SolarMount Series Rail Span Table uses a single L-foot connection to the roof, wall or stand-off. Please refer to the **Part III** for more installation information.

Table 8. L-Foot SolarMount Series Rail Span

SM - SolarMount HD - SolarMount Heavy Duty

Span (ft)	Distributed Load (pounds/linear foot)																
	20	25	30	40	50	60	80	100	120	140	160	180	200	220	240	260	
2	SM	SM	SM	SM	SM	SM	SM	SM	SM	SM	SM	SM	SM	SM	SM	SM	
2.5	SM	SM	SM	SM	SM	SM	SM	SM	SM	SM	SM	SM	SM	SM	HD	HD	HD
3	SM	SM	SM	SM	SM	SM	SM	SM	SM	SM	SM	HD	HD	HD	HD	HD	
3.5	SM	SM	SM	SM	SM	SM	SM	SM	SM	SM	HD	HD	HD	HD			
4	SM	SM	SM	SM	SM	SM	SM	SM	SM	HD	HD	HD	HD				
4.5	SM	SM	SM	SM	SM	SM	SM	SM	HD	HD	HD						
5	SM	SM	SM	SM	SM	SM	SM	SM	HD	HD	HD						
5.5	SM	SM	SM	SM	SM	SM	SM	HD	HD	HD							
6	SM	SM	SM	SM	SM	SM	SM	HD	HD								
6.5	SM	SM	SM	SM	SM	SM	SM	HD	HD								
7	SM	SM	SM	SM	SM	SM	HD	HD									
7.5	SM	SM	SM	SM	SM	SM	SM	HD	HD								
8	SM	SM	SM	SM	SM	SM	HD	HD									
8.5	SM	SM	SM	SM	SM	HD	HD										
9	SM	SM	SM	SM	HD	HD	HD										
9.5	SM	SM	SM	SM	HD	HD	HD										
10	SM	SM	SM	HD	HD	HD	HD										
10.5	SM	SM	SM	HD	HD	HD											
11	SM	SM	HD	HD	HD	HD											
11.5	SM	HD	HD	HD	HD	HD											
12	SM	HD	HD	HD	HD	HD											

Step 4: Select Rail Type

Selecting a span and rail type affects the price of your installation. Longer spans produce fewer wall or roof penetrations. However, longer spans create higher point load forces on the building structure. A point load force is the amount of force transferred to the building structure at each connection.

It is the installer’s responsibility to verify that the building structure is strong enough to support the point load forces.

Step 5: Determine the Downforce Point Load, R (lbs), at each connection based on rail span

When designing the Unirac Flush Mount Installation, you must consider the downforce Point Load, R (lbs) on the roof structure.

The Downforce, Point Load, R (lbs), is determined by multiplying the Total Design Load, P (psf) (Step 1) by the Rail Span, L (ft) (Step 3) and the Module Length Perpendicular to the Rails, B (ft) divided by two.

$$R \text{ (lbs)} = PLB/2$$

R = Point Load (lbs)

P = Total Design Load (psf)

L = Rail Span (ft)

B = Module Length Perpendicular to Rails (ft)

It is the installer’s responsibility to verify that the building structure is strong enough to support the maximum point loads calculated according to Step 5.

Table 10. Downforce Point Load Calculation

Total Design Load (downforce) (max of case 1, 2 or 3):	P		psf	Step 1
Module length perpendicular to rails:	B	x	ft	
Rail Span:	L	x	ft	Step 4
			/2	
Downforce Point Load:	R		lbs	

Step 6: Determine the Uplift Point Load, R (lbs), at each connection based on rail span

You must also consider the Uplift Point Load, R (lbs), to determine the required lag bolt attachment to the roof (building) structure.

Table 11. Uplift Point Load Calculation

Total Design Load (uplift):	P		psf	Step 1
Module length perpendicular to rails:	B	x	ft	
Rail Span:	L	x	ft	Step 4
			/2	
Uplift Point Load:	R		lbs	

Table 12. Lag pull-out (withdrawal) capacities (lbs) in typical roof lumber (ASD)

	Specific gravity	Lag screw specifications
		⁵ / ₁₆ " shaft,* per inch thread depth
Douglas Fir, Larch	0.50	266
Douglas Fir, South	0.46	235
Engelmann Spruce, Lodgepole Pine (MSR 1650 f & higher)	0.46	235
Hem, Fir, Redwood (close grain)	0.43	212
Hem, Fir (North)	0.46	235
Southern Pine	0.55	307
Spruce, Pine, Fir	0.42	205
Spruce, Pine, Fir (E of 2 million psi and higher grades of MSR and MEL)	0.50	266

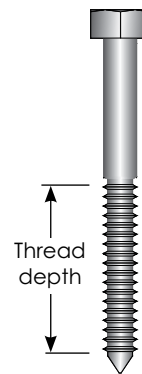

Use **Table 12** to select a lag bolt size and embedment depth to satisfy your Uplift Point Load Force, R (lbs), requirements. Divide the uplift pointload (from **Table 11**) by the withdrawal capacity in the 2nd column of **Table 12**. This results in inches of ⁵/₁₆ lagbolt embedded thread depth needed to counteract the uplift force. If other than lag bolt is used (as with a concrete or steel), consult fastener mfr documentation.

It is the installer’s responsibility to verify that the substructure and attachment method is strong enough to support the maximum point loads calculated according to Step 5 and Step 6.

Sources: American Wood Council, NDS 2005, Table 11.2A, 11.3.2A.

Notes: (1) Thread must be embedded in the side grain of a rafter or other structural member integral with the building structure.

(2) Lag bolts must be located in the middle third of the structural member.

(3) These values are not valid for wet service.

(4) This table does not include shear capacities. If necessary, contact a local engineer to specify lag bolt size with regard to shear forces.

(5) Install lag bolts with head and washer flush to surface (no gap). Do not over-torque.

(6) Withdrawal design values for lag screw connections shall be multiplied by applicable adjustment factors if necessary. See Table 10.3.1 in the American Wood Council NDS for Wood Construction.

*Use flat washers with lag screws.

Part III. Installing SolarMount

The Unirac Code-Compliant Installation Instructions support applications for building permits for photovoltaic arrays using Unirac PV module mounting systems.

This manual, SolarMount Planning and Assembly, governs installations using the SolarMount and SolarMount HD (Heavy Duty) systems.

[3.1.] SolarMount rail components

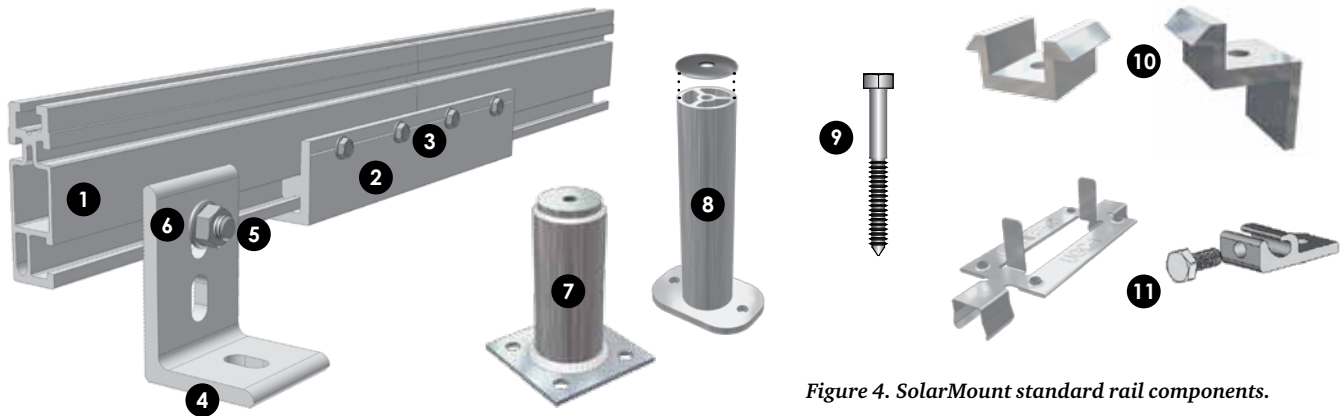

Figure 4. SolarMount standard rail components.

- 1 Rail** – Supports PV modules. Use two per row of modules. Aluminum extrusion, anodized.
- 2 Rail splice** – Joins and aligns rail sections into single length of rail. It can form either a rigid or thermal expansion joint, 8 inches long, predrilled. Aluminum extrusion, anodized.
- 3 Self-drilling screw** – (No. 10 x 3/4") – Use 4 per rigid splice or 2 per expansion joint. Galvanized steel.
- 4 L-foot** – Use to secure rails either through roofing material to building structure or standoffs. Refer to loading tables for spacing. Note: Please contact Unirac for use and specification of double L-foot.
- 5 L-foot bolt** (3/8" x 3/4") – Use one per L-foot to secure rail to L-foot. Stainless steel.
- 6 Flange nut** (3/8") – Use one per L-foot to secure rail to L-foot. Stainless steel.
- 7 Flattop standoff** (optional) (3/8") – Use standoffs to increase the height of the array above the surface of the roof or to allow for the use of flashings. Use one per L-foot. One piece: Service Condition 4 (very severe) zinc-plated-welded steel. Includes 3/8" x 3/4" bolt with

lock washer for attaching L-foot. Flashings: Use one per standoff. Unirac offers appropriate flashings for both standoff types.

Note: There is also a flange type standoff that does not require an L-foot.

- 8 Aluminum two-piece standoff** (optional) (4" and 7") – Use one per L-foot. Two-piece: Aluminum extrusion. Includes 3/8" x 3/4" serrated flange bolt with EPDM washer for attaching L-foot, and two 5/16" lag bolts.
- 9 Lag screw for L-foot** (5/16") – Attaches standoff to rafter.
- 10 Top Mounting Clamps**
- 11 Top Mounting Grounding Clips and Lugs**

Installer supplied materials:

- **Lag screw for L-foot** – Attaches L-foot or standoff to rafter. Determine the length and diameter based on pull-out values. If lag screw head is exposed to elements, use stainless steel. Under flashings, zinc plated hardware is adequate.
- **Waterproof roofing sealant** – Use a sealant appropriate to your roofing material. Consult with the company currently providing warranty of roofing.

[3.2.] Installing SolarMount with top mounting clamps

This section covers SolarMount rack assembly where the installer has elected to use top mounting clamps to secure modules to the rails. It details the procedure for flush mounting SolarMount systems to a pitched roof.

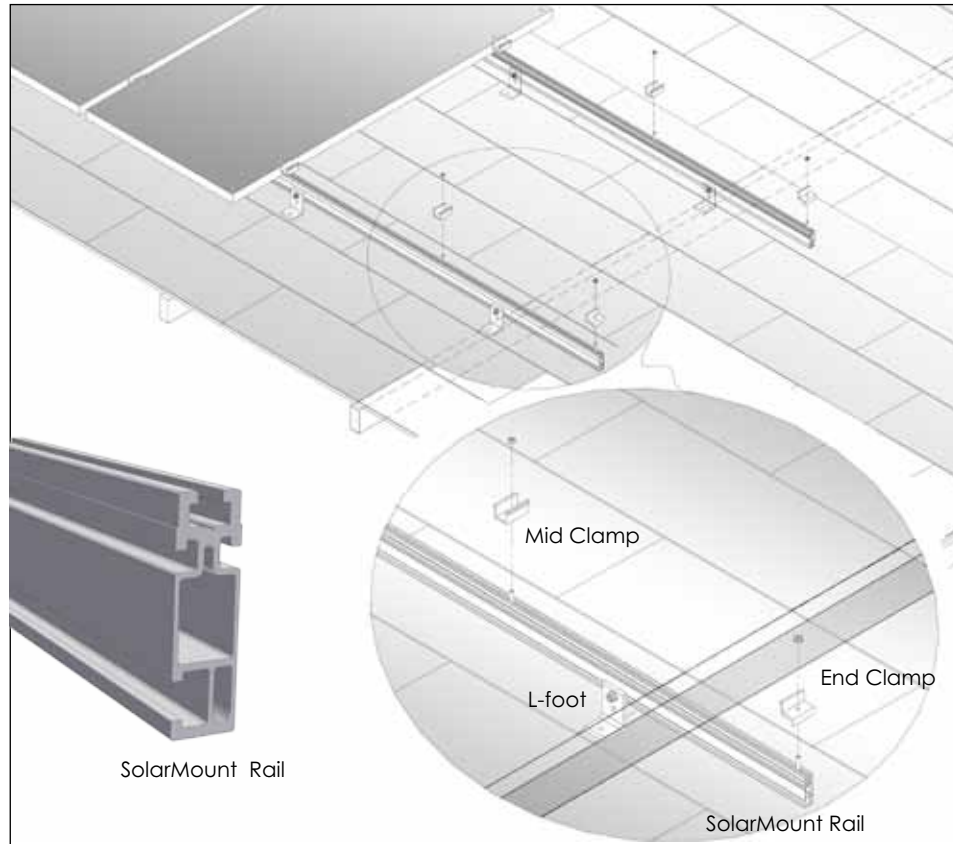



Figure 5. Exploded view of a flushmount installation mounted with L-feet.

Table 13. Wrenches and torque

	Wrench size	Recommended torque (ft-lbs)
1/4" hardware	7/16"	10 
3/8" hardware	9/16"	30

Torques are not designated for use with wood connectors.

Top mounting clamps and L-feet **require** the use of anti-seize.



All top down clamps and L-feet must be installed with anti-seize to prevent galling and provide uniformity in clamp load. UniRac Inc recommends Silver Grade LocTite Anti-Seize Item numbers: 38181, 80209, 76732, 76759, 76764, 80206, and 76775, or equivalent. 1/4" - 20 hardware used in conjunction with top down clamps must be installed to 10 ft-lbs of torque. When using UGC-1, UGC-2, WEEB 9.5 and WEEB 6.7, 1/4" - 20 hardware must be installed to 10 ft-lbs of torque. Additionally, when used with a top down clamp, the module frame cross section must be boxed shaped as opposed to a single, l-shaped member. Please refer to installation supplement 910: **Galling and Its Prevention** for more information on galling and anti-seize and installation manual 225: **Top Mounting Unirac Grounding Clips and WEEBLugs** for more information on Grounding Clips."

[3.2.1] Planning your SolarMount installations

The installation can be laid out with rails parallel to the rafters or perpendicular to the rafters. Note that SolarMount rails make excellent straight edges for doing layouts.

Center the installation area over the structural members as much as possible.

Leave enough room to safely move around the array during installation. Some building codes require minimum clearances around such installations, and the user should be directed to also check 'The Code'.

The width of the installation area equals the length of one module.

The length of the installation area is equal to:

- the total width of the modules,
- plus 1 inch for each space between modules (for mid-clamp),
- plus 3 inches (1½ inches for each pair of end clamps).

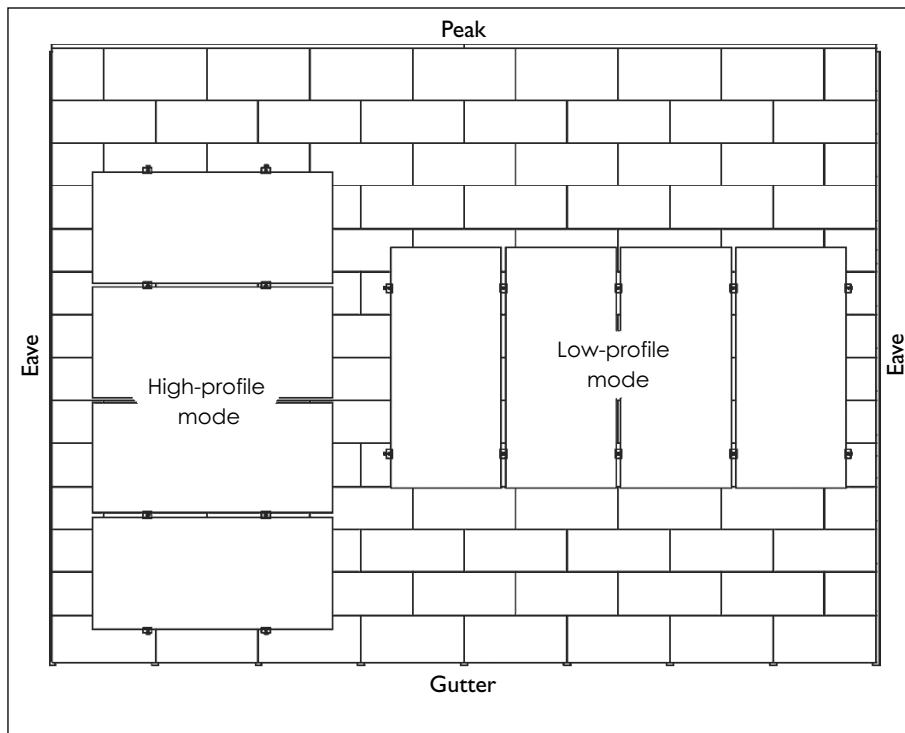

Figure 6. Rails may be placed parallel or perpendicular to rafters.

[3.2.2] Laying out L-feet

L-feet (**Fig. 7**) can be used for attachment through existing roofing material, such as asphalt shingles, sheathing or sheet metal to the building structure.

Use **Figure 8 or 9** below to locate and mark the position of the L-foot lag screw holes within the installation area.

If multiple rows are to be installed adjacent to one another, it is not likely that each row will be centered above the rafters.

Adjust as needed, following the guidelines in **Figure 9** as closely as possible.



Figure 7

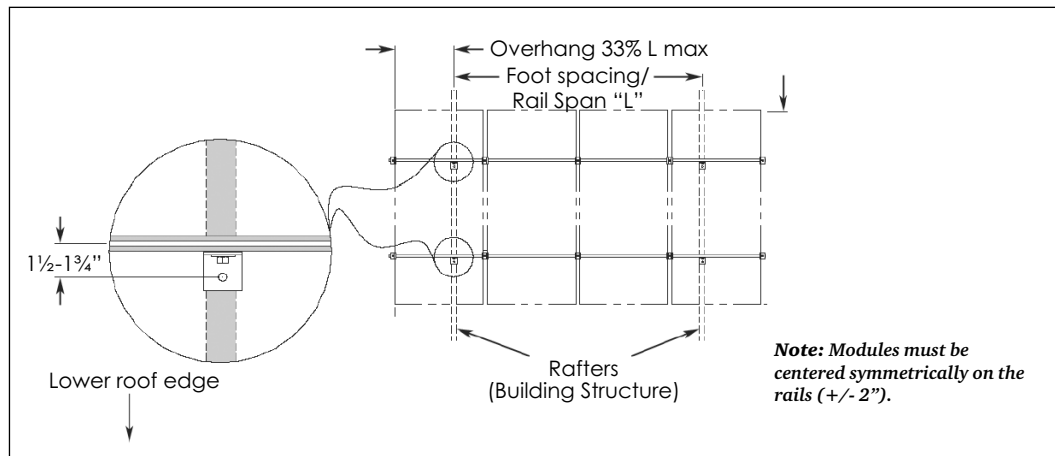

Figure 8. Layout with rails perpendicular to rafters.

Installing L-feet:

Drill pilot holes through the roof into the center of the rafter at each L-foot lag screw hole location.

Squirt sealant into the hole, and on the shafts of the lag screws. Seal the underside of the L-foot with a suitable sealant. Consult with the company providing the roofing warranty.

Securely fasten the L-feet to the roof with the lag screws. Ensure that the L-feet face as shown in **Figure 8 and 9**. For greater ventilation, the preferred method is to place the single-slotted square side of the L-foot against the roof with the double-slotted side perpendicular to the roof. If the installer chooses to mount the L-foot with the long leg against the roof, the bolt slot closest to the bend must be used.

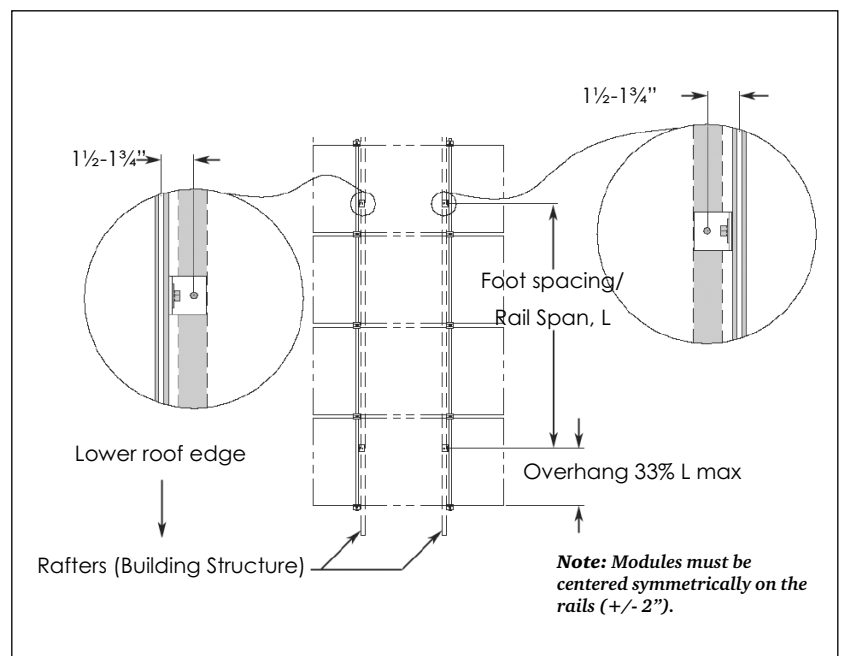

Figure 9. Layout with rails parallel to rafters.

[3.2.3] Laying out standoffs

Standoffs (Figure 10) are used to increase the height of the array above the surface of the roof. Pair each standoff with a flashing to seal the lag bolt penetrations to the roof.

Use Figure 11 or 12 to locate and mark the location of the standoff lag screw holes within the installation area.

Remove the tile or shake underneath each standoff location, exposing the roofing underlayment. Ensure that the standoff base lies flat on the underlayment, but remove no more material than required for the flashings to be installed properly.

The standoffs must be firmly attached to the building structure.



Figure 10. Raised flange standoff (left) and flat top standoff used in conjunction with an L-foot.

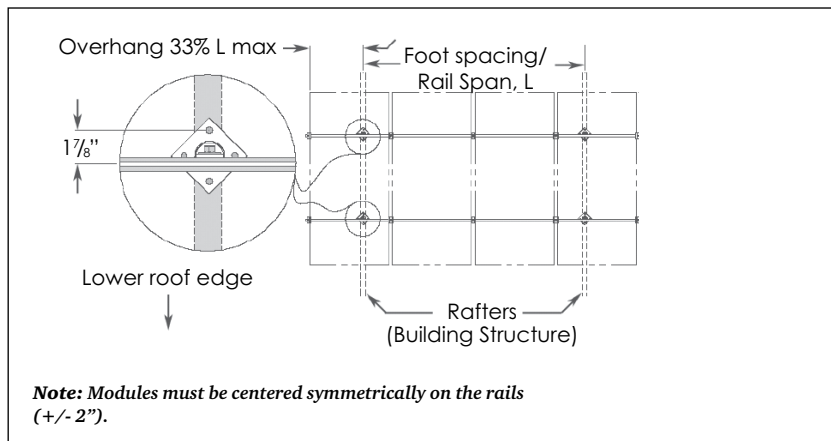

Figure 11. Layout with rails perpendicular to rafters. perpendicular to rafters.

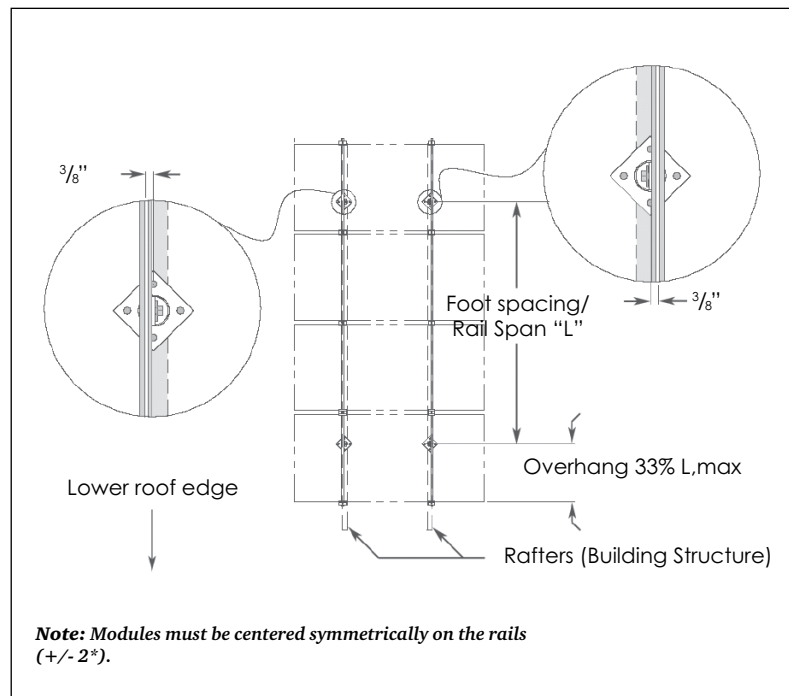

Figure 12. Layout with rails parallel to rafters.

If multiple high-profile rows are to be installed adjacent to each other, it may not be possible for each row to be centered above the rafters. Adjust as needed, following the guidelines of Fig. 12 as closely as possible.

Installing standoffs:

Drill 3/16 inch pilot holes through the underlayment into the center of the rafters at each standoff location. Securely fasten each standoff to the rafters with the two 5/16" lag screws.

Ensure that the standoffs face as shown in Figure 11 or 12.

Unirac steel and aluminum two-piece standoffs (1-5/8" O.D.) are designed for collared flashings available from Unirac.

Install and seal flashings and standoffs using standard building practices or as the company providing roofing warranty directs.

[3.2.4] Installing SolarMount rails

Keep rail slots free of roofing grit or other debris. Foreign matter will cause bolts to bind as they slide in the slots.

Installing Splices: If your installation uses SolarMount splice bars, attach the rails together (**Fig. 13**) before mounting the rails to the footings. Use splice bars only with flush installations or those that use low-profile tilt legs.

Although structural, the joint is not as strong as the rail itself. A rail should always be supported by **more than one** footing on **both** sides of the splice. (Reference installation manual 908, Splices/Expansion Joints.)

Mounting Rails on Footings: Rails may be attached to either of two mounting holes in the L-feet (**Fig. 14**). Mount in the lower hole for a low profile, more aesthetically pleasing installation. Mount in the upper hole for a higher profile, which will maximize airflow under the modules. This will cool them more and may enhance performance in hotter climates.

Slide the $\frac{3}{8}$ -inch mounting bolts into the footing bolt slots. Loosely attach the rails to the footings with the flange nuts.

Ensure that the rails are oriented to the footings as shown in **Figure 8, 9, 11, or 12**, whichever is appropriate.

Aligning the Rail End: Align one pair of rail ends to the edge of the installation area (**Fig. 15 or Fig. 16**).

The opposite pair of rail ends will overhang the side of the installation area. Do not trim them off until the installation is complete.

If the rails are perpendicular to the rafters (**Fig. 15**), either end of the rails can be aligned, but the first module must be installed at the aligned end.

If the rails are parallel to the rafters (**Fig. 16**), the aligned end of the rails must face the lower edge of the roof. Securely tighten all hardware after alignment is complete (20 ft lbs).

Mount modules to the rails as soon as possible. Large temperature changes may bow the rails within a few hours if module placement is delayed.

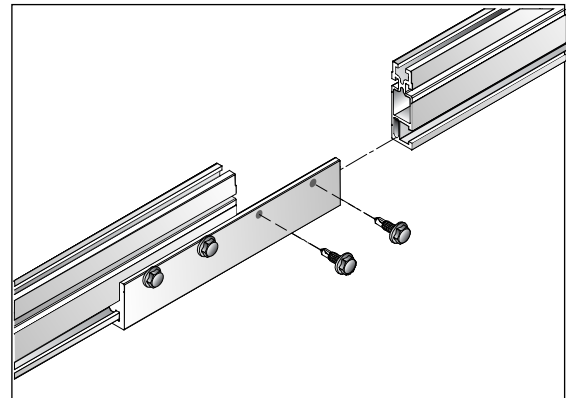

Figure 13. Splice bars slide into the footing bolt slots of SolarMount rail sections.

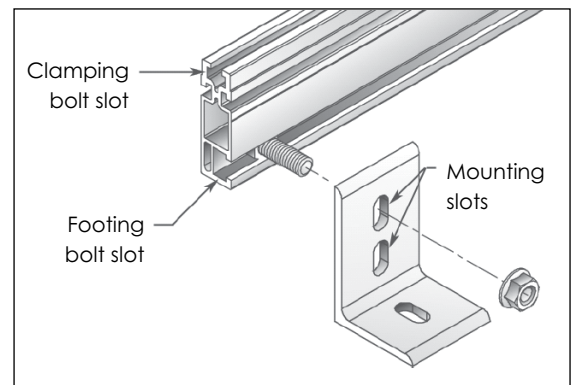

Figure 14. Foot-to-rail splice attachment

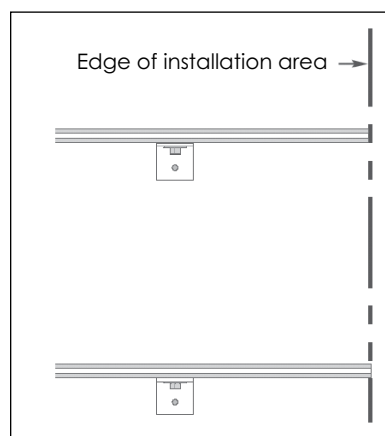

Figure 15. Rails perpendicular to the rafters.

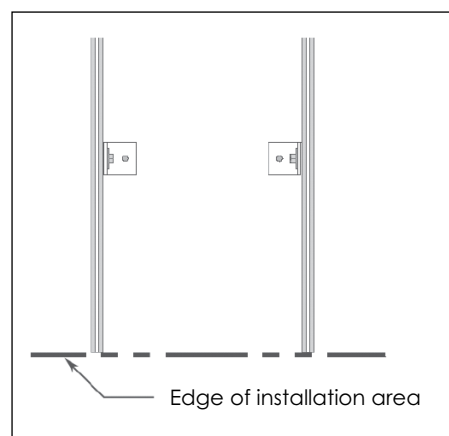

Figure 16. Rails parallel to the rafters.

[3.2.5] Installing the modules

Pre-wiring Modules: If modules are the Plug and Play type, no pre-wiring is required, and you can proceed directly to “Installing the First Module” below.

If modules have standard J-boxes, each module should be pre-wired with one end of the intermodule cable for ease of installation. For safety reasons, module pre-wiring should not be performed on the roof.

Leave covers off J-boxes. They will be installed when the modules are installed on the rails.

Installing the First Module: In high-profile installations, the best practice would be to install a safety bolt (1/4”-20 x 1/2”) and flange nut (both installer provided) fastened to the module bolt slot at the aligned (lower) end of each rail. It will prevent the lower end clamps and clamping bolts from sliding out of the rail slot during installation.

If there is a return cable to the inverter, connect it to the first module. Close the J-box cover. Secure the first module with T-bolts and end clamps at the aligned end of each rail. Allow half an inch between the rail ends and the end clamps (**Fig. 18**). Finger tighten flange nuts, center and align the module as needed, and securely tighten the flange nuts (10 ft lbs).

Installing the Other Modules: Lay the second module face down (glass to glass) on the first module. Connect intermodule cable to the second module and close the J-box cover. Turn the second module face up (**Fig. 17**). With T-bolts, mid-clamps and flange nuts, secure the adjacent sides of the first and second modules. Align the second module and securely tighten the flange nuts (**Fig. 19**).

For a neat installation, fasten wire management devices to rails with self-drilling screws.

Repeat the procedure until all modules are installed. Attach the outside edge of the last module to the rail with end clamps.

Trim off any excess rail, being careful not to cut into the roof. Allow half an inch between the end clamp and the end of the rail (**Fig. 18**).

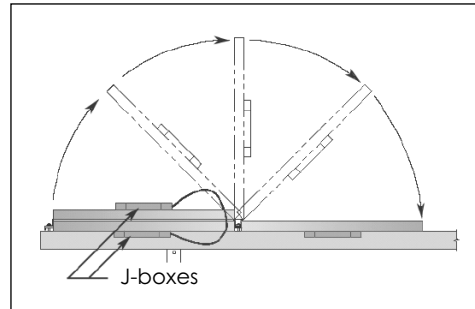

Figure 17

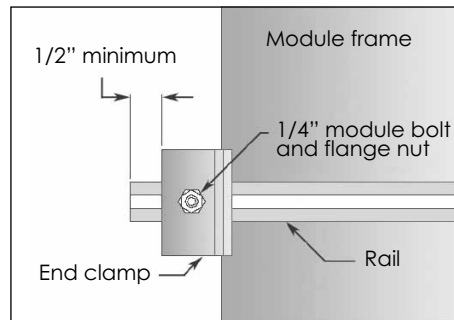

Figure 18

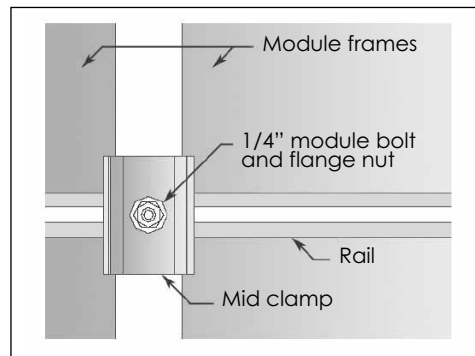

Figure 19

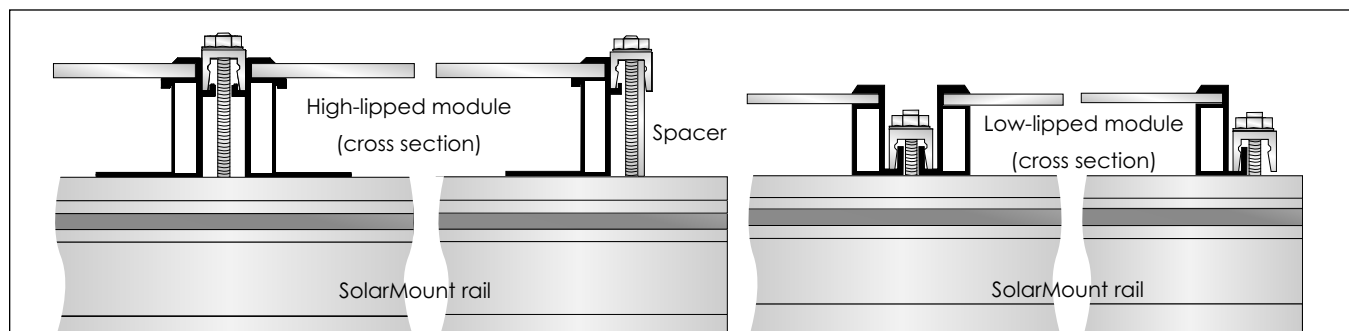

Figure 20. Mid clamps and end clamps for lipped-frame modules are identical. A spacer for the end clamps is necessary only if the lips are located high on the module frame.

[3.3] Installing SolarMount with bottom mounting clips

This section covers SolarMount rack assembly where the installer has elected to use bottom mounting clamps to secure modules to the rails. It details the procedure for flush mounting SolarMount systems to a pitched roof.

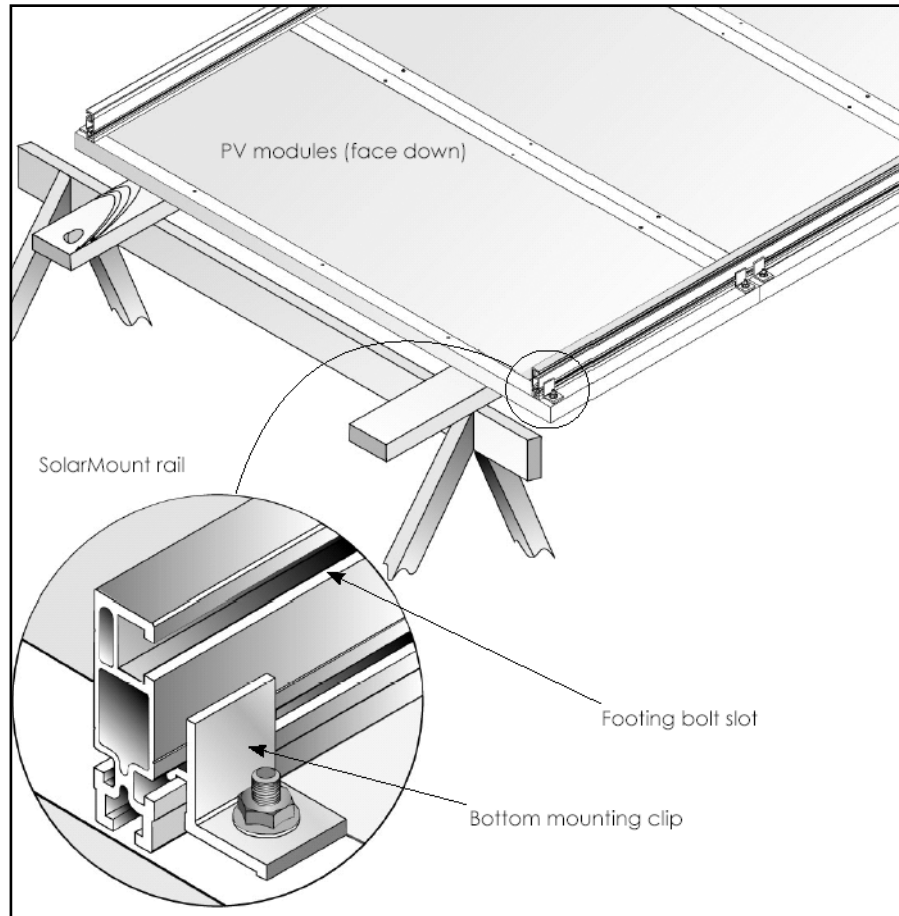

Figure 21. SMR and CB components

Table 14. Wrenches and torque

	Wrench size	Recommended torque (ft-lbs)
1/4" hardware	7/16"	10
3/8" hardware	9/16"	30

Note: Torque specifications do not apply to lag bolt connections.



Stainless steel hardware can seize up, a process called galling. To significantly reduce its likelihood, (1) apply lubricant to bolts, preferably an anti-seize lubricant, available at auto parts stores, (2) shade hardware prior to installation, and (3) avoid spinning on nuts at high speed. See Installation Supplement 910, Galling and Its Prevention, at www.unirac.com.

[3.3.1] Planning the installation area

Decide on an arrangement for clips, rails, and L-feet (Fig. 22).

Use Arrangement A if the full width of the rails contacts the module. Otherwise use Arrangement B.

Caution: If you choose Arrangement B, either (1) use the upper mounting holes of the L-feet or (2) be certain that the L-feet and clip positions don't conflict.

If rails must be parallel to the rafters, it is unlikely that they can be spaced to match rafters. In that case, add structural supports – either sleepers over the roof or mounting blocks beneath it. These additional members must meet code; if in doubt, consult a professional engineer.

Never secure the footings to the roof decking alone. Such an arrangement will not meet code and leaves the installation and the roof itself vulnerable to severe damage from wind.

Leave enough room to safely move around the array during installation. The width of a rail-module assembly equals the length of one module. Note that L-feet may extend beyond the width of the assembly by as much as 2 inches on each side. The length of the assembly equals the total width of the modules.

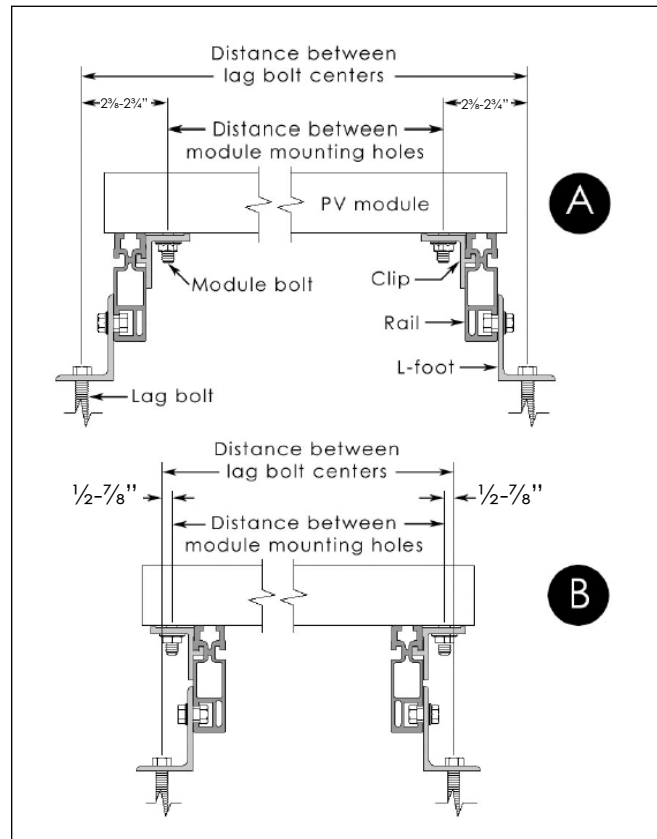

Figure 22. Clip Arrangements A and B

[3.3.2] Laying out the installing L-feet

L-feet are used for installation through existing low profile roofing material, such as asphalt shingles or sheet metal. They are also used for most ground mount installations. To ensure that the L-feet will be easily accessible during flush installation:

- Use the PV module mounting holes nearest the ends of the modules.
- Situate the rails so that footing bolt slots face outward.

The single slotted square side of the L-foot must always lie against the roof with the double-slotted side perpendicular to the roof.

Foot spacing (along the same rail) and rail overhang depend on design wind loads.

Install half the L-feet:

- If rails are perpendicular to rafters (Fig. 23), install the feet closest to the lower edge of the roof.
- If rails are parallel to rafters (Fig. 24), install the feet for one of the rails, but not both.

For the L-feet being installed now, drill pilot holes through the roofing into the center of the rafter at each lag screw hole location.

Squirt sealant into the hole and onto the shafts of the lag screws. Seal the underside of the L-feet with a sealant. Securely fasten the L-feet to the building structure with the lag screws. Ensure that the L-feet face as shown in Figure 23 or Figure 24.

Hold the rest of the L-feet and fasteners aside until the panels are ready for the installation.

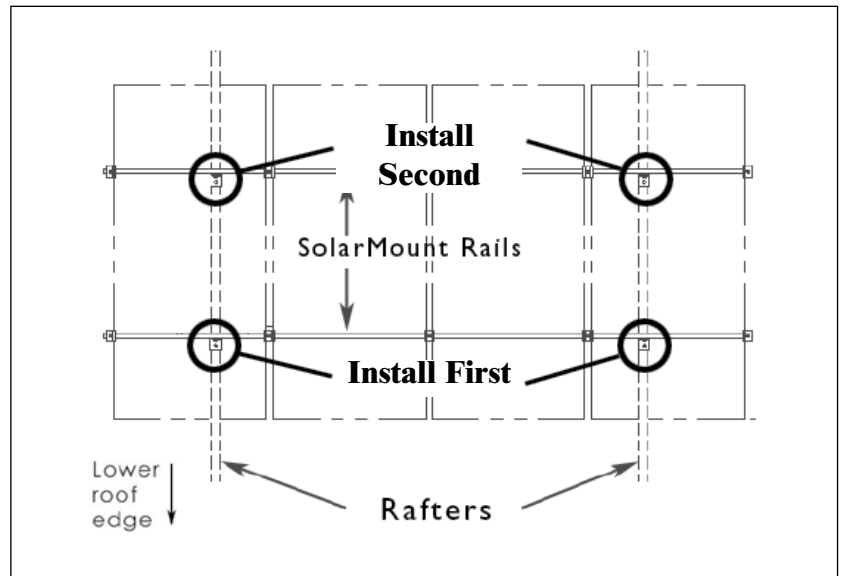

Figure 23. Layout with rails perpendicular to rafters.

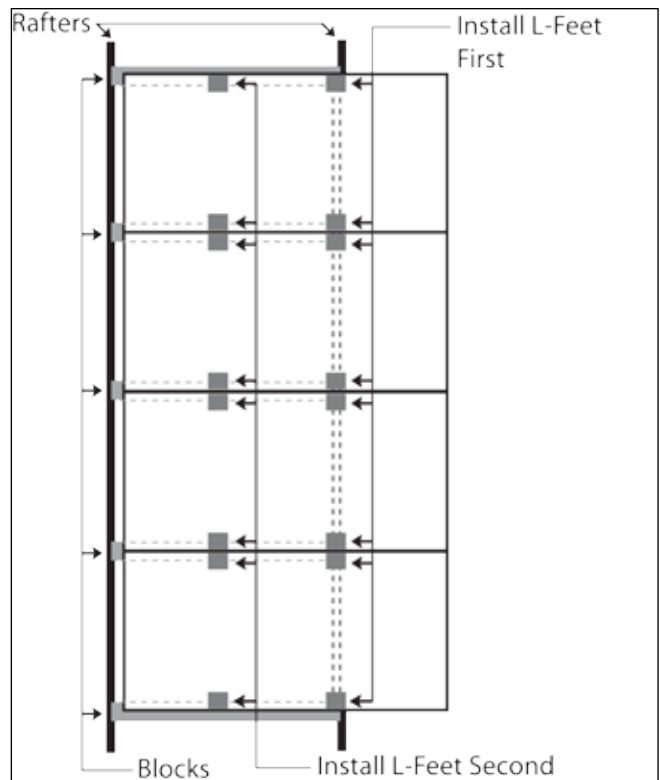

Figure 24. Layout with rails parallel to rafters.

[3.3.3] Attaching modules to the rails

Lay the modules for a given panel face down on a surface that will not damage the module glass. Align the edges of the modules and snug them together (Fig. 21, page 22).

Trim the rails to the total width of the modules to be mounted. Place a rail adjacent to the outer mounting holes. Orient the footing bolt slot outward. Place a clip slot adjacent to the mounting holes, following the arrangement you selected earlier.

Assemble the clips, mounting bolts, and flange nuts. Torque the flange nuts to 10 foot-pounds.

[3.3.4] Installing the module-rail assembly

Bring the module-rail assembly to the installation site. Keep rail slots free of debris that might cause bolts to bind in the slots.

Consider the weight of a fully assembled panel. Unirac recommends safety lines whenever lifting one to a roof.

Align the panel with the previously installed L-feet. Slide 3/8 inch L-foot mounting bolts onto the rail and align them with the L-foot mounting holes. Attach the panel to the L-feet and finger tighten the flange nuts.

Rails may be attached to either of two mounting holes in the footings (Fig. 25).

- Mount in the lower hole for a low, more aesthetically pleasing installation.
- Or mount in the upper hole to maximize a cooling airflow under the modules. This may enhance performance in hotter climates.

Adjust the position of the panel as needed to fit the installation area. Slide the remaining L-feet bolts onto the other rail, attach L-feet, and finger tighten with flange nuts. Align L-feet with mounting holes previously drilled into the roof. Install lag bolts into remaining L-feet as described in “Laying out and installing L-feet” above.

Torque all footing flange nuts to 30 foot-pounds. Verify that all lag bolts are securely fastened.

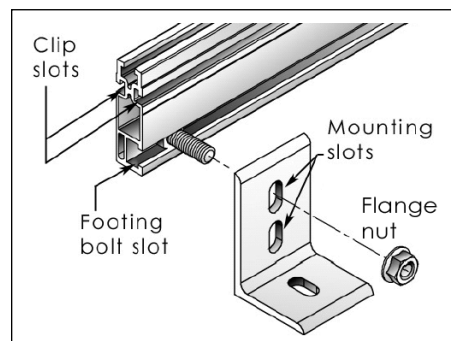

Figure 25. Leg-to-rail attachment

[3.4] Installing SolarMount with grounding clips and lugs

Clips and lugs are sold separately.

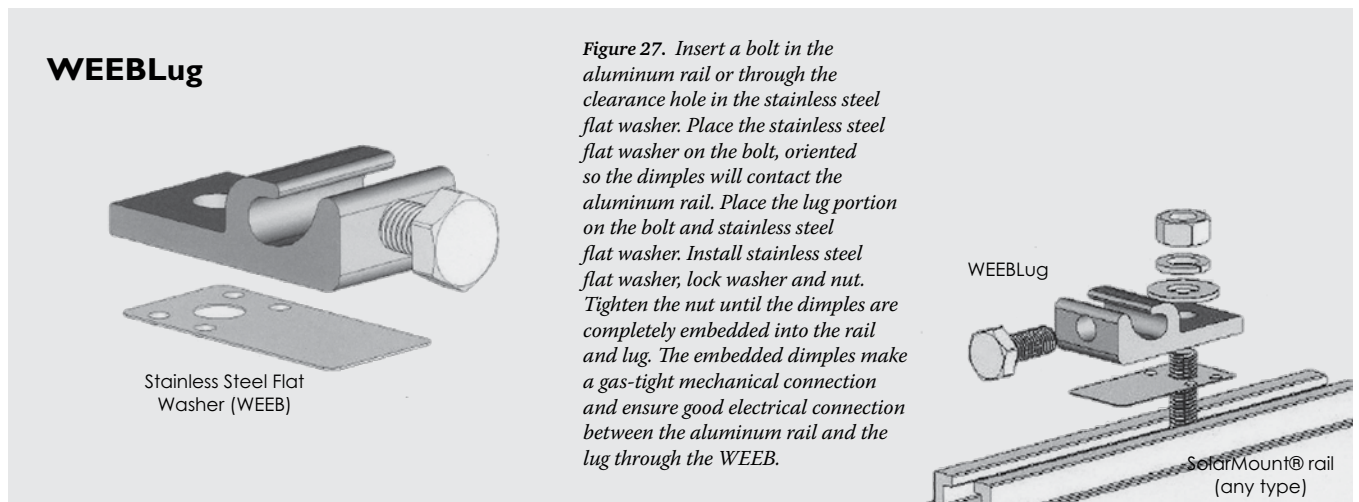
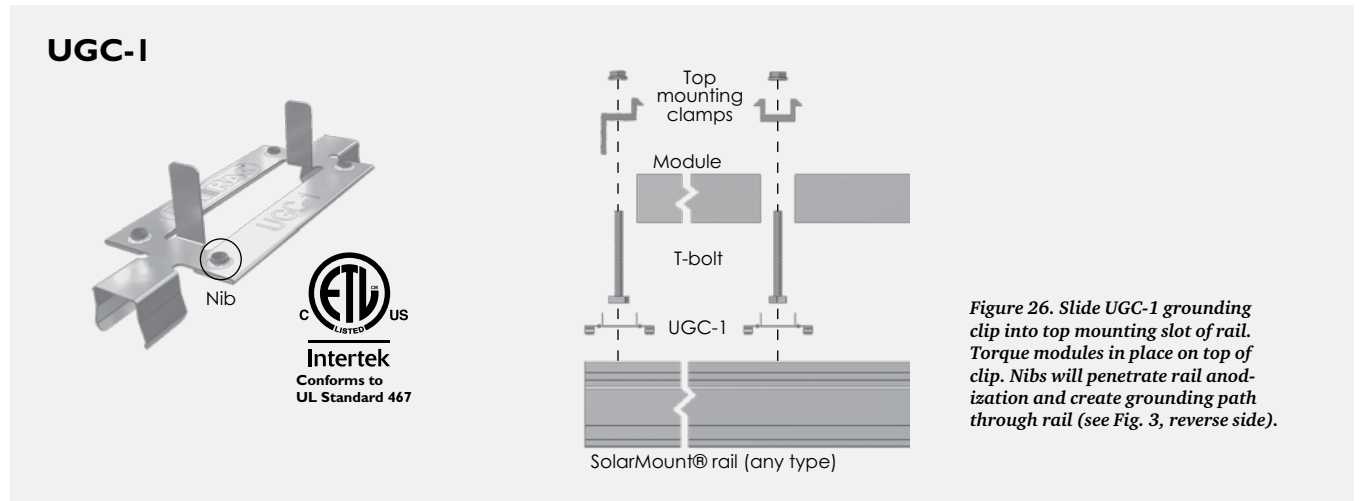

Figure 28. UGC-1 layout for even and odd number of modules in row. "X" denotes places to install UGC-1.

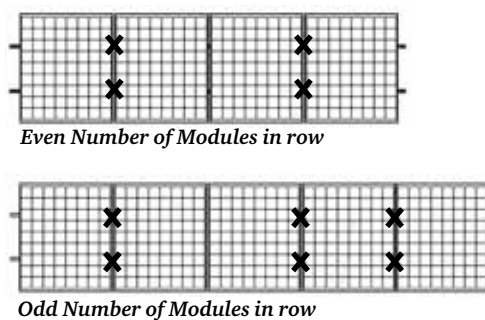
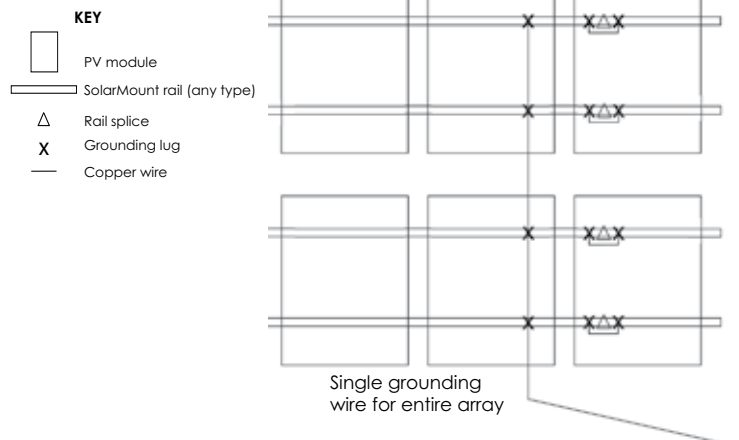

Figure 29. Single wire grounding with spliced rails.



Warranty Information

See <http://www.unirac.com> for current warranty documents and information.