



**Safety Technology  
International, Inc.**

## Stopper Station Series

SS-2002, SS-2005, SS-2009 Push Buttons  
Key to Reset, Momentary and Turn-to-Reset



ADA  
for operation



Key Reset Models		Momentary Models		Turn-to-Reset Models	
SS-2002	Red	SS-2005	Red	SS-2009	Red
SS-2102	Green	SS-2105	Green	SS-2109	Green
SS-2202	Yellow	SS-2205	Yellow	SS-2209	Yellow
SS-2302	White	SS-2305	White	SS-2309	White
SS-2402	Blue	SS-2405	Blue	SS-2409	Blue

ALL MODELS COME WITH A COLOR MATCHED SURFACE MOUNT BACKBOX

**NOTE:** For SS-2XX5/LTUL the enclosed timer is to be used and installed per the enclosed LT-1UL installation sheet. SS-2XX5/LTUL maximum rating 30 VDC 3A. For access control installations, power for the LT-1 Timer must be supplied by a power source listed to UL294. When used for access control, this device shall be used as part of an access controlled egress door system. It is up to the local AHJ to allow use of this device in place of an automatic sensor. For higher security installations, lower time limits should be used.

**We protect the things that protect you.**

# Installation and Service Instructions

## STOPPER STATION SERIES 2000 PUSH BUTTON

### SAFETY NOTICE TO INSTALLERS AND USERS

**INSTALLATION NOTE:** This push button has been tested according to UL2017. It is important to read, understand and follow all instructions provided with this product. Non-fire alarm initiating devices are listed in UL category UEHX. It is the installer's responsibility to comply with NFPA72 and 101, NEC, mounting specifications according to ADA and other applicable fire and electrical codes. To avoid electrical shock, DO NOT attempt to install this product when power is on. To avoid possible confusion with fire alarm initiating devices, do not mount a red stopper station near a manual fire alarm initiating device. ADA mounting compliance requires the operable part of the initiating device shall not be less than 1.1m (3 1/2 ft.) or greater than 1.37m (4 1/2 ft.) above finished floor service. After installation and testing are complete, provide a copy of this manual to all personnel responsible for testing and maintenance of this product.

#### I. GENERAL

<b>Product Dimensions</b>	See page 7
<b>Switch Rating</b>	SS-2XX5/LTUL MODELS, FORM C CONTACTS ON TIMER, RATED 30 VDC 3A
2 Form C contacts	
125/250 VAC, 10 A, 1/2 HP	
30 VDC, 6 A	

#### II. CONTENTS LIST

QTY.	DESCRIPTION
1	Button and Switch Assembly
1	18061 Reset Key
1	19001 Allen Head Screw #8-32 x 3/8 in.
1	19015 Allen Wrench 3/32 in.
4	19068 Screw 3.5mm x 13mm
2	19060 Screw #6-32 x 1 in.
1	19021 Ground Screw
4	19039 #6 x 1 1/4 in. SS SMS
4	19018 Plastic Screw Anchor
1	71100A Surface Backbox

#### III. INSTRUCTIONS

Housing Removal .....	Page 2
Backbox Preparation .....	Page 3
Wire Connections .....	Page 4
Installation .....	Page 5
Key Reset Procedure.....	Page 6
Product Dimensions .....	Page 7
Warranty .....	Page 7

# HOUSING REMOVAL

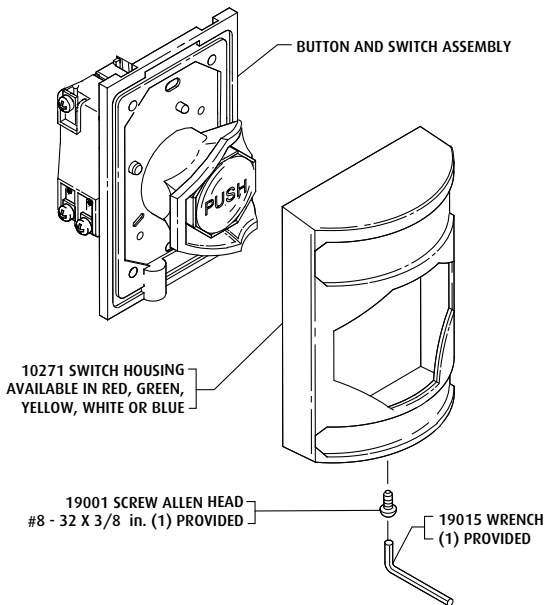

REMOVE SCREW. PULL BOTTOM OF HOUSING OUT AND LIFT UP UNTIL  
TABS ARE RELEASED FROM SLOTS IN BUTTON AND SWITCH ASSEMBLY.

# BACKBOX PREPARATION

(NOT INCLUDED WITH FLUSH MOUNT COVERS)

DRILL POINT LOCATIONS PROVIDED  
TOP AND BOTTOM FOR 1/2 in.  
CONDUIT FITTINGS.  
DRILL AS NEEDED

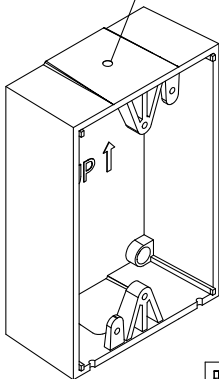

FIELD DRILLING FOR CONDUIT ENTRY IS  
REQUIRED. LOCATIONS SHOWN ALSO  
APPLY TO OPPOSITE, PARALLEL SIDE.

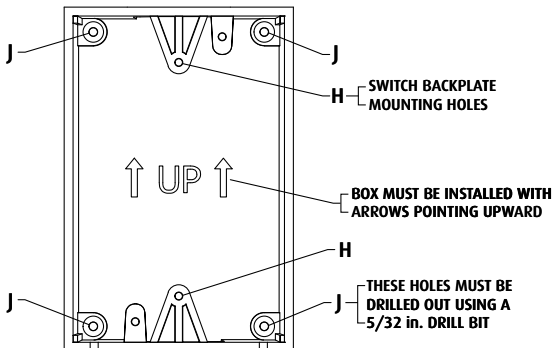

# WIRE CONNECTIONS

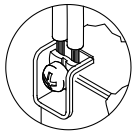
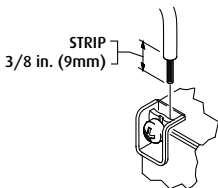
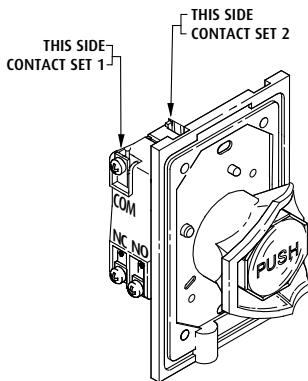
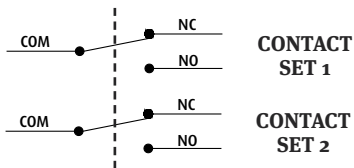

**CORRECT METHOD OF  
INSERTING MULTIPLE LEADS  
(1 WIRE EACH  
SIDE OF SCREW)**

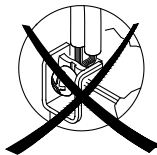

**INCORRECT METHOD OF  
INSERTING MULTIPLE LEADS  
(BOTH WIRES ON  
ONE SIDE OF SCREW)**

# INSTALLATION

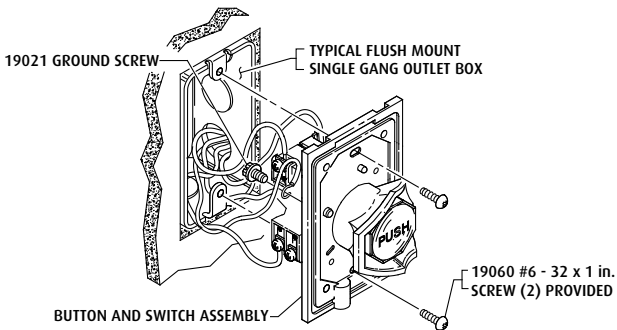
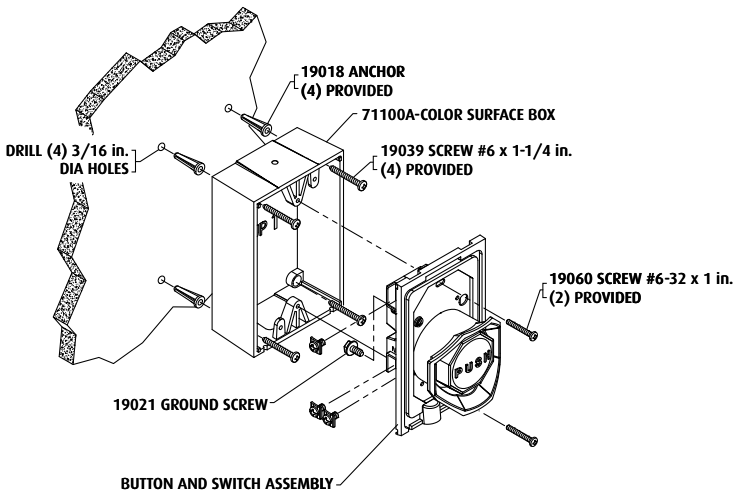

## KEY RESET PROCEDURE (#2 BUTTON)

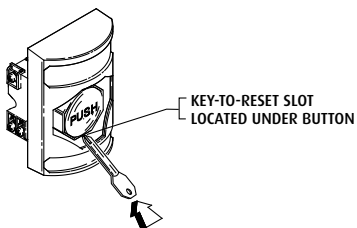

VIEW IN DIRECTION OF ARROW A

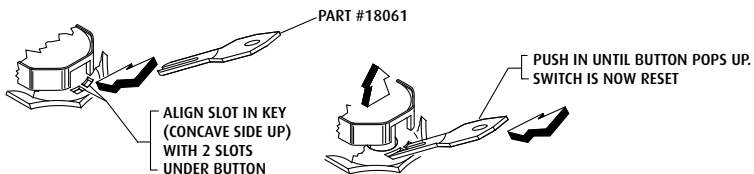

## TURN-TO-RESET PROCEDURE (#9 BUTTON)

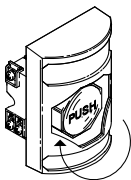

TO RESET, TURN BUTTON IN DIRECTION OF ARROW  
UNTIL BUTTON POPS UP.

# PRODUCT DIMENSIONS

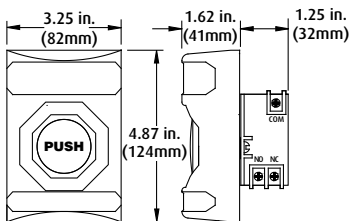

**PRODUCT DIMENSIONS  
ALL MODELS  
WITHOUT BACKBOX**

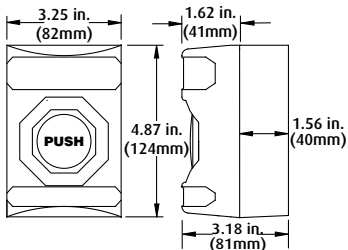

**PRODUCT DIMENSIONS  
ALL MODELS WITH  
BACKBOX**

## Warranty

Three year guarantee against breakage of polycarbonate in normal use (one year on electro mechanical and electronic components).

Electronic warranty form at [www.sti-usa.com/wc14](http://www.sti-usa.com/wc14).

## Safety Technology International, Inc.

2306 Airport Rd • Waterford, MI 48327  
Phone: 248-673-9898 • Fax: 248-673-1246  
800-888-4STI (4784) • [www.sti-usa.com](http://www.sti-usa.com)

## Safety Technology International (Europe) Ltd.

Unit 49G Pipers Road • Park Farm Industrial Estate • Redditch  
Worcestershire • B98 0HU • England • Tel: 44 (0) 1527 520 999  
Fax: 44 (0) 1527 501 999 • Freephone: 0800 085 1678 (UK only)  
E-mail: [info@sti-europe.com](mailto:info@sti-europe.com) • Web: [www.sti-europe.com](http://www.sti-europe.com)

