

MODEL ZMH - HEAVY DUTY LENGTH SENSOR

- HEAVY DUTY INDUSTRIAL CONSTRUCTION
- QUADRATURE OUTPUT
- BUILT-IN SPRING TENSIONING
- VERTICAL, HORIZONTAL, OR UPSIDE-DOWN MOUNTING
- EASY INSTALLATION
- VARIOUS MEASURING WHEELS AVAILABLE
- VARIOUS MOUNTING CONFIGURATIONS



DESCRIPTION

Designed for heavy duty sensing applications, the Heavy Duty Length Sensor, Model ZMH, is versatile and easy-to-use.

It features a built-in spring-loaded torsion arm that provides a simple-to-adjust torsion load, allowing the unit to be mounted in almost any orientation, including upside down. Using a properly selected wheel, the ZMH can be used on almost any surface, while operating at speeds up to 3000 feet per minute. Whether you need to measure speed, position, or distances, the Model ZMH is the ideal solution.

Open Collector Output Wiring

The ZMH sensors have open collector outputs. An open collector output brings the uncommitted collector of the encoder switching device to the external world. Because the collector element is not associated with the sensor supply voltage, the sensor output collector may be "pulled up" to external voltages different than the encoder supply voltage (30 VDC maximum). NPN open collector outputs are current sinking devices. An output signal will not be generated unless a pull-up resistor is connected from the open-collector to the positive side of an external supply. The same supply can be used for powering the unit and for the pull-up resistor.

ORDERING INFORMATION

MODEL NO.	DESCRIPTION	PPR	PART NUMBER
ZMH *	Heavy Duty Length Sensor with Quadrature Output	250	ZMH0250B
		500	ZMH0500B
		1000	ZMH1000B
		2000	ZMH2000B
		2500	ZMH2500B
MBZM	Mounting Bracket and Shaft	N/A	MBZM0001
	Double Wheel Pivot Mount and Shaft	N/A	MBZM0002

* Mounting shaft not included.

LENGTH SENSOR MEASUREMENT ACCURACY

Factors which affect measurement accuracy include Measuring Wheel accuracy and wear, and material conditions. Ideally, materials which are hard, thin and strong provide good readings, conversely, soft, thick and elastic materials can present problems in obtaining true readings. Where this effect is constant, Counter or Rate Indicators with "input scaling" can compensate for Measuring Wheel wear and material elastic and compliance errors. In addition, English/Metric conversions may also be accomplished.

SAFETY SUMMARY

All safety related regulations, local codes and instructions that appear in the literature or on equipment must be observed to ensure personal safety and to prevent damage to either the instrument or equipment connected to it. If equipment is used in a manner not specified by the manufacturer, the protection provided by the equipment may be impaired.

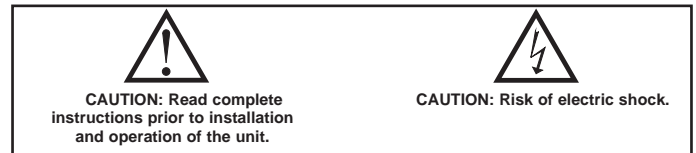

SPECIFICATIONS

ELECTRICAL SPECIFICATIONS

1. **INPUT VOLTAGE:** 4.75 to 28 VDC.
2. **INPUT CURRENT:** 100 mA max (65 mA typical) with no output load
3. **OUTPUTS:** NPN Open Collector Transistor, $V_{OH} = 30$ VDC max.; 20 mA max. current. Incremental - Two square waves in quadrature with A leading B for clockwise rotation, as viewed from the wheel side.
4. **MAX FREQUENCY:** 200 KHz
5. **NOISE IMMUNITY:** Tested to BS EN61000-6-2; BS EN50081-2; BS EN61000-4-2; BS EN61000-4-3; BS EN61000-4-6, BS EN500811
6. **SYMMETRY:** 180° ($\pm 18^\circ$) electrical

DIMENSIONS In inches (mm)

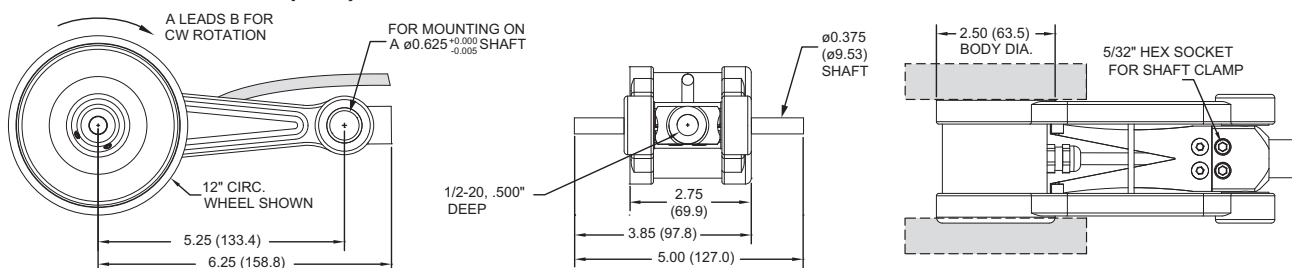

Note: All dimensions are in inches with a tolerance of +0.01" unless otherwise specified.

7. **QUAD. PHASING:** 90° ($\pm 22.5^\circ$) electrical
8. **MIN. EDGE SEP:** 67.5° electrical
9. **ACCURACY:** Within 0.017° mechanical or 1 arc-minute from true position. (for PPR>189)

MECHANICAL SPECIFICATIONS

1. **MAXIMUM MECHANICAL SPEED:** 3000 RPM
2. **SHAFT MATERIAL:** Stainless Steel
3. **SHAFT SIZE:** 0.375"
4. **RADIAL SHAFT LOAD:** 10 lb. max. controlled by spring torsion.
5. **STARTING TORQUE:** 1.0 oz-in typical
6. **ELECTRICAL CONNECTION:** 2 meter Cable, (foil and braid shield, 24 AWG conductors).

FUNCTION	CABLE WIRE COLOR
+VDC	Red
Com	Black
A	White
B	Green
Shield	Bare

7. **MOUNTING:** 5/8" diameter thru hole with clamp
8. **HOUSING:** powder coated aluminum.
9. **WEIGHT:**
 ZMH: 2.15 lb. (0.975 Kg)
 MBZM0001: 1.5 lb. (0.68 Kg)
 MBZM0002: 0.15 lb.. (68.04 g)

ENVIRONMENTAL SPECIFICATIONS

1. **OPERATING TEMPERATURE:** -20°C to 85°C
2. **STORAGE TEMPERATURE:** -25°C to +85°C
3. **HUMIDITY:** 98% RH non-condensing
4. **VIBRATION:** 10 g @ 58 to 500 Hz
5. **SHOCK:** 80 g @ 11 msec duration
6. **SEALING:** IP50

MOUNTING BRACKET - MBZM0001

This accessory angle mounting bracket allows for a variety of mounting positions and makes installation of the ZMH even easier. Mounting shaft included with mounting bracket.

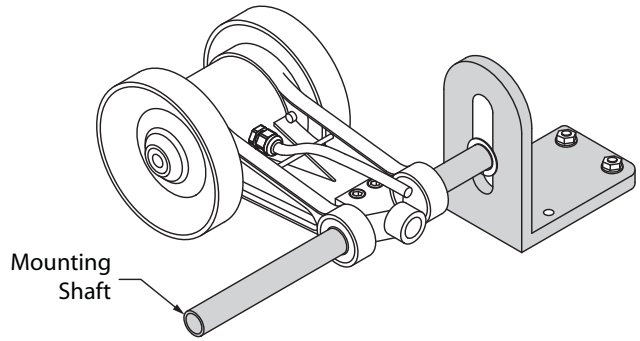

DIMENSIONS In inches (mm)

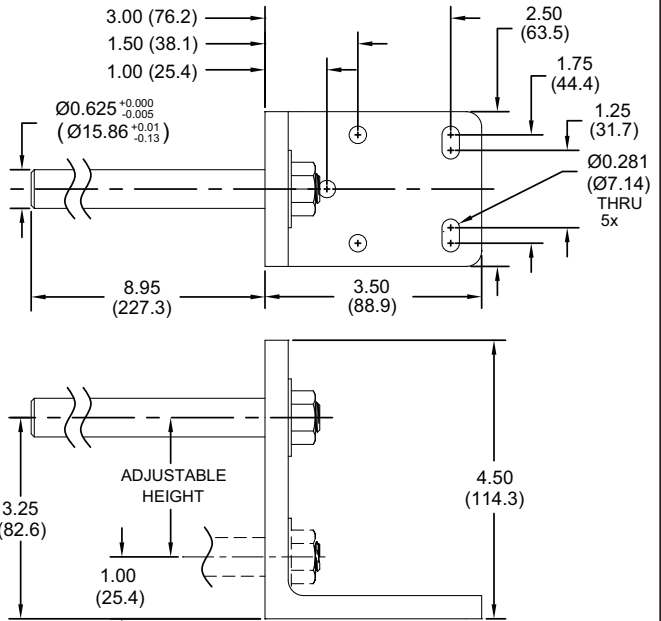

DOUBLE WHEEL PIVOT MOUNT - MBZM0002

This accessory allows the unit to rotate freely to maintain equal pressure on both wheels, accomodating uneven/angled surfaces and mounting misalignment. Pivot mounting shaft included with MBZM0002. For installation of unit, use the mounting bracket and shaft included with MBZM0001.

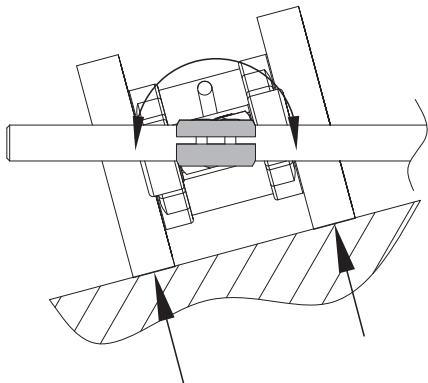
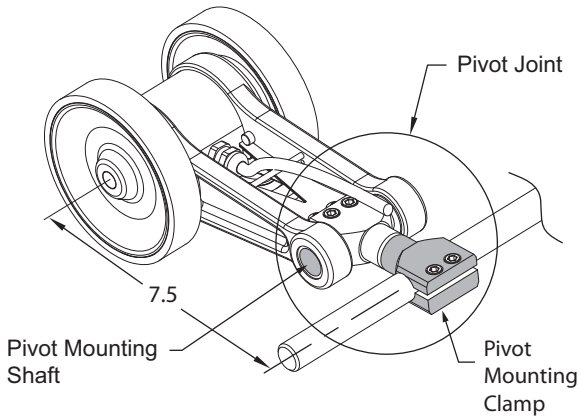

LENGTH SENSOR ACCESSORIES

SEPARATE LENGTH MEASURING WHEELS - DIMENSIONS In Inches (mm)

<p>WHEEL CODE OR</p> <p>Round Section Replaceable Tire .210" Section Dia. Black Neoprene</p> <p>FOR USE ON: Metal, paper, foil, film and hard plastics. Line contact on material being measured, convenient when available measuring track is narrow or for measuring on end of roller beside passing material.</p> <p>Max. Speed: 600 RPM</p>	<p>WHEEL CODE OF</p> <p>Tan, Smooth Polyurethane Tread</p> <p>FOR USE ON: Soft, smooth materials such as soft paper, matting, cardboard, fine weave textiles. Broad wheel tread minimizes contact pressure and tan polyurethane tread minimizes marking.</p> <p>Max. Speed: 600 RPM</p> <p>Balanced version of 1ft. circumference available. Balanced to ANSI S2.19-1989 Quality Grade 6.3 @ 3000 RPM.</p>	<p>WHEEL CODE OK</p> <p>Diamond Knurled Aluminum Tread</p> <p>FOR USE ON: Rubber, coarse weave fabrics, rough wood surfaces, foam, insulation.</p> <p>Max. Speed: 600 RPM</p> <p>Balanced version of 1ft. circumference available. Balanced to ANSI S2.19-1989 Quality Grade 6.3 @ 3000 RPM.</p>
--	--	--

SELECTING APPROPRIATE WHEEL SIZE & PPR (Pulses Per Rev.) OF ROTARY PULSE GENERATOR

When the desired output of a length sensor and wheel combination is either in feet or inch units, selection of the proper combination is relatively straight forward. For example, with a 1-foot wheel circumference, a 1 PPR Rotary Pulse Generator will deliver 1 pulse/ft, 12 PPR would deliver 12 pulses/ft (1 pulse/inch); 100 PPR would yield 100 pulses/ft; and 120 PPR would permit measuring to 1/10th of an inch (1/120th of a foot).

WHEELS & REPLACEMENT TIRES FOR CODE OR WHEELS

ORDERING INFORMATION

WHEEL CODE	CIRCUMFERENCE	TOLERANCE	PART NUMBER
OR	1 foot (1/3 yd)	±0.40%	WF1000OR
	1/3 meter	±0.40%	WM0333OR
	4/10ths yard	±0.40%	WY0400OR
	4/10ths meter	±0.40%	WM0400OR
OF	1 foot (1/3 yd)	±0.35%	WF1000OF
	1/3 meter	±0.30%	WM0333OF
	4/10ths yard	±0.30%	WY0400OF
	4/10ths meter	±0.30%	WM0400OF
BF (Balanced)	1 foot (1/3 yd)	±0.40%	WF1000BF

WHEEL CODE	CIRCUMFERENCE	TOLERANCE	PART NUMBER
OK	1 foot (1/3 yd)	±0.35%	WF1000OK
	1/3 meter	±0.30%	WM0333OK
	4/10ths yard	±0.30%	WY0400OK
	4/10ths meter	±0.30%	WM0400OK
BK (Balanced)	1 foot (1/3 yd)	±0.35%	WF1000BK
Replacement Tires for OR Wheels	1 foot (1/3 yd)		TORF1000
	1/3 meter		TORM0333
	4/10ths yard		TORY0400
	4/10ths meter		TORM0400

Note: After installation of measuring wheels, ensure guards, shields or other devices are in place to protect personnel from rotating equipment.

ZMH INSTALLATION

INSTALLATION:

- Slide ZMH over a fixed $\text{Ø}5/8$ " ($\text{Ø}0.625 \pm 0/-0.005$ ") shaft. The optional ZMH Mounting Bracket (MBZM0001) is shown in the picture.
- While rotating the ZMH clamp to apply a spring load, securely tighten the two clamp bolts with a $5/32$ " (supplied) or 4 mm hex "L" key.

Note 1: A $1/2 - 20$ bolt can be threaded into the end of the clamp to aid in loading the spring as shown. If a $1/2 - 20$ bolt is not handy, then a $\text{Ø}0.45$ " or smaller rod, bolt, screw driver etc. works as well.

Note 2: The spring should not be preloaded too much or it may come in contact with the spring limit pins and the ZMH will not have sufficient travel to accommodate variations in the surface height of the material being measured. For most applications, the spring setting in its mid-range (5-6 lbs.) is sufficient.

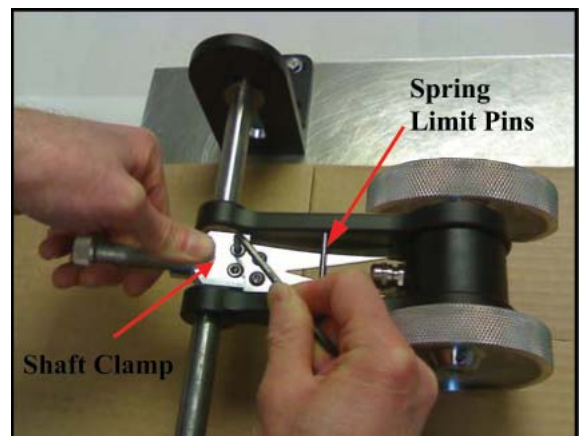

DOUBLE WHEEL PIVOT INSTALLATION (MBZM0002):

Note: It is recommended that double wheel ZMH's be installed with the optional Double Wheel Pivot. The pivot allows the unit to rotate freely to maintain equal pressure on both wheels, accommodating uneven/angled surfaces and mounting misalignment.

1. Thread the pivot clamp into the end of the ZMH's clamp by hand until the threads just bottom out then back out approximately 1 revolution to allow for rotation after installation.
2. Slide the pivot clamp over a fixed $\text{Ø}5/8"$ ($\text{Ø}0.625 +0/-0.005"$) shaft. The optional ZMH Mounting Bracket (MBZM0001) is shown in the picture.
3. While applying a load to the spring, securely tighten the two clamp bolts with a $5/32"$ (supplied) or 4mm hex "L" key.

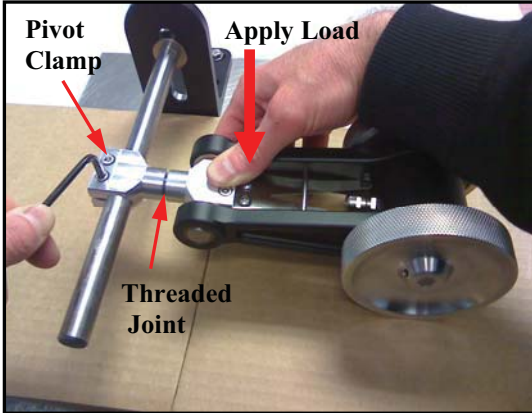

CONNECTOR EXIT ORIENTATION ADJUSTMENT:

1. Slide the ZMH over a $\text{Ø}5/8"$ ($\text{Ø}0.625 +0/-0.005"$) shaft and tighten the clamp bolts with the supplied $5/32"$ hex "L" key.
2. Remove the measuring wheel(s) using the supplied $3/32"$ hex "L" wrench to loosen the set screws.
3. Remove 6 screws (3 on each side) from the side plates using the supplied $7/64"$ hex "L" key.
4. Rotate body of encoder to desired orientation, aligning bolt pattern with one of six unique positions (see inset drawing).
5. Replace side plate screws and measuring wheel(s), making sure to tighten screws securely.

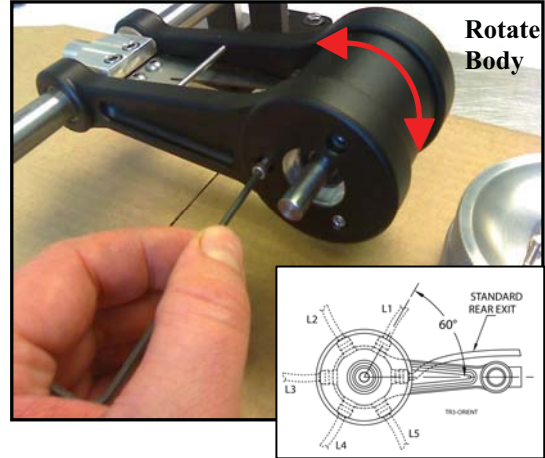

LIMITED WARRANTY

The Company warrants the products it manufactures against defects in materials and workmanship for a period limited to two years from the date of shipment, provided the products have been stored, handled, installed, and used under proper conditions. The Company's liability under this limited warranty shall extend only to the repair or replacement of a defective product, at The Company's option. The Company disclaims all liability for any affirmation, promise or representation with respect to the products.

The customer agrees to hold Red Lion Controls harmless from, defend, and indemnify RLC against damages, claims, and expenses arising out of subsequent sales of RLC products or products containing components manufactured by RLC and based upon personal injuries, deaths, property damage, lost profits, and other matters which Buyer, its employees, or sub-contractors are or may be to any extent liable, including without limitation penalties imposed by the Consumer Product Safety Act (P.L. 92-573) and liability imposed upon any person pursuant to the Magnuson-Moss Warranty Act (P.L. 93-637), as now in effect or as amended hereafter.

No warranties expressed or implied are created with respect to The Company's products except those expressly contained herein. The Customer acknowledges the disclaimers and limitations contained herein and relies on no other warranties or affirmations.

Red Lion Controls
Headquarters
20 Willow Springs Circle
York PA 17406
Tel +1 (717) 767-6511
Fax +1 (717) 764-0839

Red Lion Controls
Europe
Printerweg 10
NL - 3821 AD Amersfoort
Tel +31 (0) 334 723 225
Fax +31 (0) 334 893 793

Red Lion Controls
India
54, Vishvas Tenement
GST Road, New Ranip,
Ahmedabad-382480 Gujarat, India
Tel +91 987 954 0503
Fax +91 79 275 31 350

Red Lion Controls
China
Unit 101, XinAn Plaza
Building 13, No.99 Tianzhou Road
ShangHai, P.R. China 200223
Tel +86 21 6113-3688
Fax +86 21 6113-3683