



nCM PDT 9



STANDARD RANGE 360° SENSOR CEILING MOUNT • LOW VOLTAGE • DUAL TECHNOLOGY (PDT)

SPECIFICATIONS

FEATURES

- Patented Dual Technology with PIR / Microphonics Detection
- 360° Coverage
- Communicates w/ nLight Network
- Remotely Configurable/Upgradeable
- Push-Button Programmable
- Adjustable Time Delay
- 100 Hr Lamp Burn-in Timer
- Green LED Indicator

PHYSICAL SPECS

- SIZE 4.55" Dia. (11.56 cm)
- 1.55" Deep (3.94 cm)
- WEIGHT 6 oz
- MOUNTING
 - Ceiling Tile Surface
 - 3.5" Octagon Box
 - Single Gang Handy Box
- COLOR White
- NETWORK CONNECTION
 - 2 RJ-45 Ports

ELECTRICAL SPECS

- POWER CONSUMPTION < 3 mA
- DIMMING LOAD
 - Sinks < 20mA;
 - ~40 Ballasts @ .5mA each
- WIRES None

ENVIRONMENTAL SPECS

- OPERATING TEMP
 - 14° to 160° F (-10° to 71° C)
- RELATIVE HUMIDITY
 - 20 to 90% non-condensing
- SILICONE FREE
- ROHS COMPLIANT

OTHER

- UL and CUL Listed
- Title 24 Compliant
- 5 Year Warranty
- Assembled in the U.S.A.

Open area office lighting control is made cost effective with the use of the nCM PDT 9 Series Standard Range 360° occupancy sensor. This small, yet powerful sensor provides line of sight PIR detection of small motion in a circular pattern and combines overlapping Microphonics™ coverage for detection of occupants working in their cubical space. By installing multiple nCM PDT 9s on 30 ft (9.14 m) centers, large zones are created (typically one per circuit of lighting). The lighting is then controlled in blocks similar to manual switching. Restrooms with stalls, large storage areas with shelving, and libraries with study carrels are also easily and cost effectively controlled by the nCM PDT 9.

SENSOR OPERATION

Sensors with Passive Dual Technology (PDT) first see motion using Passive Infrared (PIR) detection and then engage Microphonics™ to hear sounds that indicate continued occupancy. This patented technology uses Automatic Gain Control (AGC) to dynamically self adapt a sensor to its environment by filtering out constant background noise and registering only noises typical of human activity. Once occupancy is detected, a relay located elsewhere within the sensor's zone is signaled to switch the line voltage lighting load on. An internal time delay, factory set at 10 minutes, keeps the sensor in the occupancy state during brief periods of no activity. The timer is adjustable, and is reset every time occupancy is re-detected. This state-of-the-art sensor requires no field calibration or adjustment.

nLIGHT OPERATION

This sensor is nLight-enabled, meaning it has the ability to communicate over an nLight network. When daisy-chain wired, using CAT-5 cabling, with other nLight-enabled sensors, power packs, or WallPods, an nLight control zone is created. Once linked to a Gateway, directly or via a Bridge, the zone becomes capable of remote status monitoring and control via SensorView software.

OPTIONS

DIMMING CONTROL (D)

- Provides dimming outputs to control 0-10 VDC dimmable ballasts
- Follows dimming commands from nLight Wallpod dimmer or SensorView software
- Adds 20 AWG violet & gray wires

ON/OFF PHOTOCELL (P)

- On/Off Operation: Full control during periods of occupancy with adequate daylight
- Inhibit Operation: Prevents lights from turning on if adequate daylight is available

AUTOMATIC DIMMING CONTROL PHOTOCELL (ADC)

- Photocell within sensor maintains total room light level by controlling levels of 0-10 VDC dimmable ballasts
- Provides a second time-out period that enable the lights to go to a dim setting before turning off
- Follows dimming commands from nLight WallPod dimmer or SensorView software
- Adds 20 AWG violet & gray wires

LOW TEMP/HIGH HUMIDITY (LT)

- Sensor electronics are coated for corrosion resistance
- Operates down to -4° F (-20° C)
- Required for bathroom & cooler/freezer applications

ORDERING INFO

nCM PDT 9 [DIMMING] [DAYLIGHTING] [TEMP/HUMIDITY]

OPTIONS	DIMMING*	DAYLIGHTING	TEMP/HUMIDITY
	Blank = None D = Dimming	Blank = None P = On/Off Photocell ADC = Auto Dimming Control Photocell	Blank = Standard LT = Low Temp

*D functionality also in ADC option

WIRING (DO NOT WIRE HOT)

T568B pin/pair assignment is recommended for all CAT-5 cables.

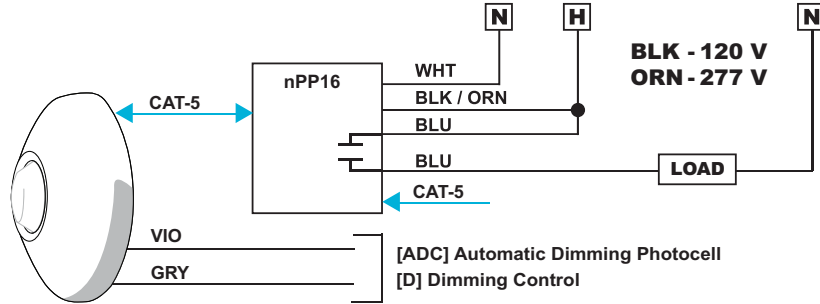

COVERAGE PATTERN

STANDARD RANGE 360° LENS WITH MICROPHONICS™

- Best choice for small motion (e.g. hand movements) detection
- Viewing angle of 56° in a 360° conical shaped pattern
- Provides 12 ft (3.66 m) radial coverage when mounted to standard 9 ft (2.74 m) ceiling
- 8 to 15 ft (2.44 to 4.57 m) mounting heights provide 10 to 20 ft (3.05 to 6.10 m) radial coverage
- Microphonics™ provides overlapping detection of human activity over the complete PIR coverage area. Advanced filtering is also utilized to prevent non-occupant noises from keeping the lights on.

SIDE VIEW

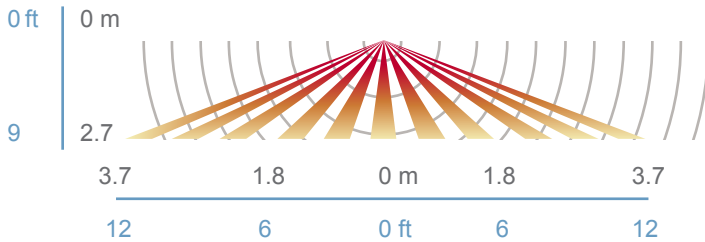

TOP VIEW

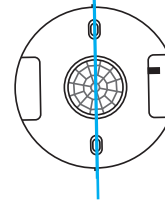
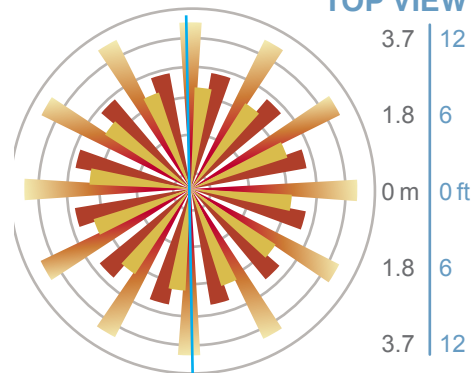

Note: Sensor's screw axis is aligned with a long detection segment

INSTALLATION

- Mount sensor directly to a ceiling tile or a metallic grid (two self-tapping screws provided)
- Sensor's mounting holes also align with standard round fixture or single gang handy box (screws not provided)
- Interconnect unit (via RJ-45 ports) with other nLight devices in lighting zone using CAT-5 cables
- Once power is received via CAT-5 connection, all devices in zone will automatically begin functioning together according to each device's defaults
- Sensor will detect motions crossing segments more effectively than motions parallel to beams
- For optimal detection, position sensor such that segments are crossed upon entrance and unable to view outside the space

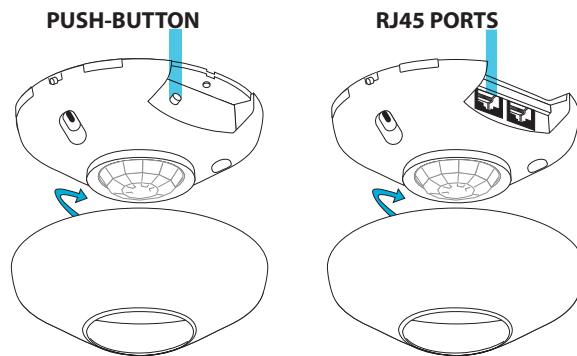

PROGRAMMING

Refer to included instruction card for default settings and directions on programming the sensor via the push-button.



WARRANTY: Sensor Switch, Inc. warrants these products to be free of defects in manufacture and workmanship for a period of 60 months. Sensor Switch, Inc., upon prompt notice of such defect, will, at its option, provide a Returned Material Authorization number and repair or replace returned product.

LIMITATIONS AND EXCLUSIONS: This Warranty is in full lieu of all other representation and expressed and implied warranties (including the implied warranties of merchantability and fitness for use) and under no circumstances shall Sensor Switch, Inc. be liable for any incidental or consequential property damages or losses.