

8 7 6 5 4 3 2 1

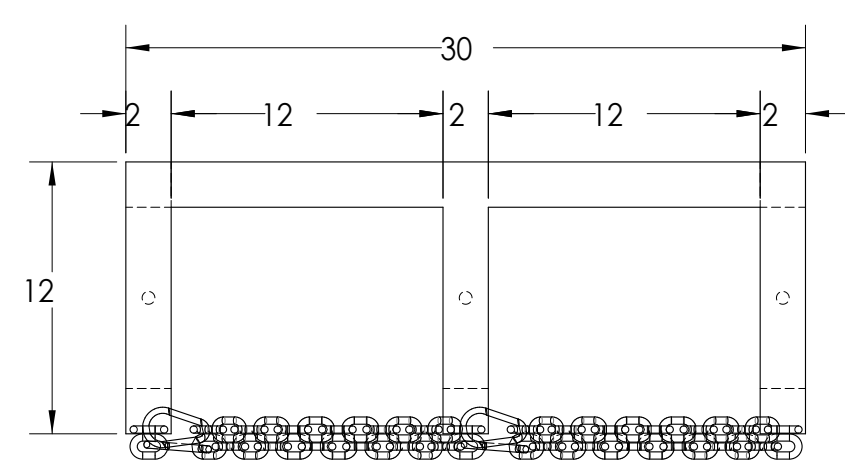

TOP

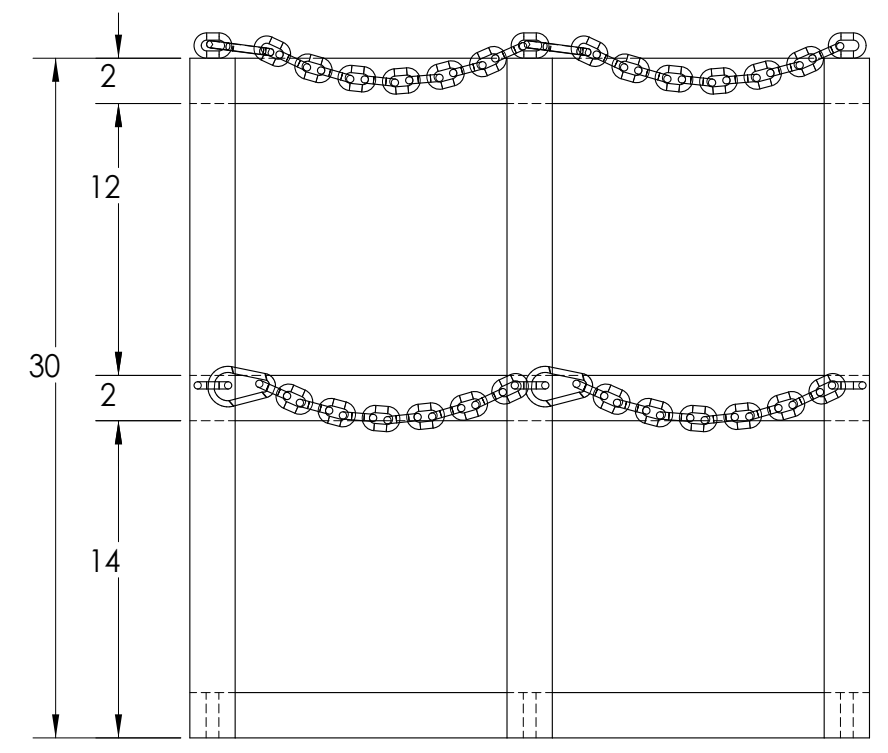

FRONT

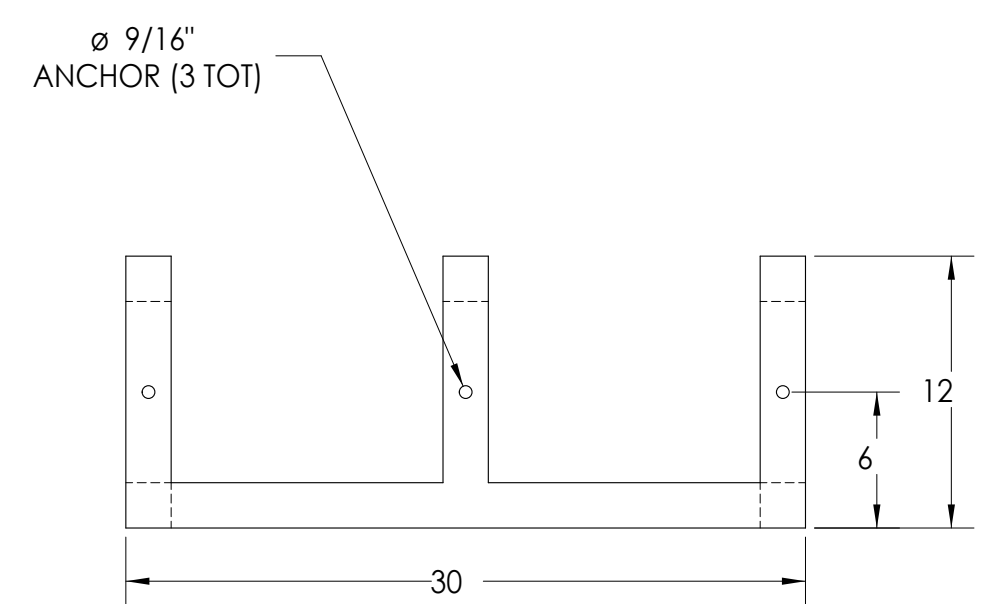

BOTTOM

NOTE: CHAINS REMOVED FOR CLARITY

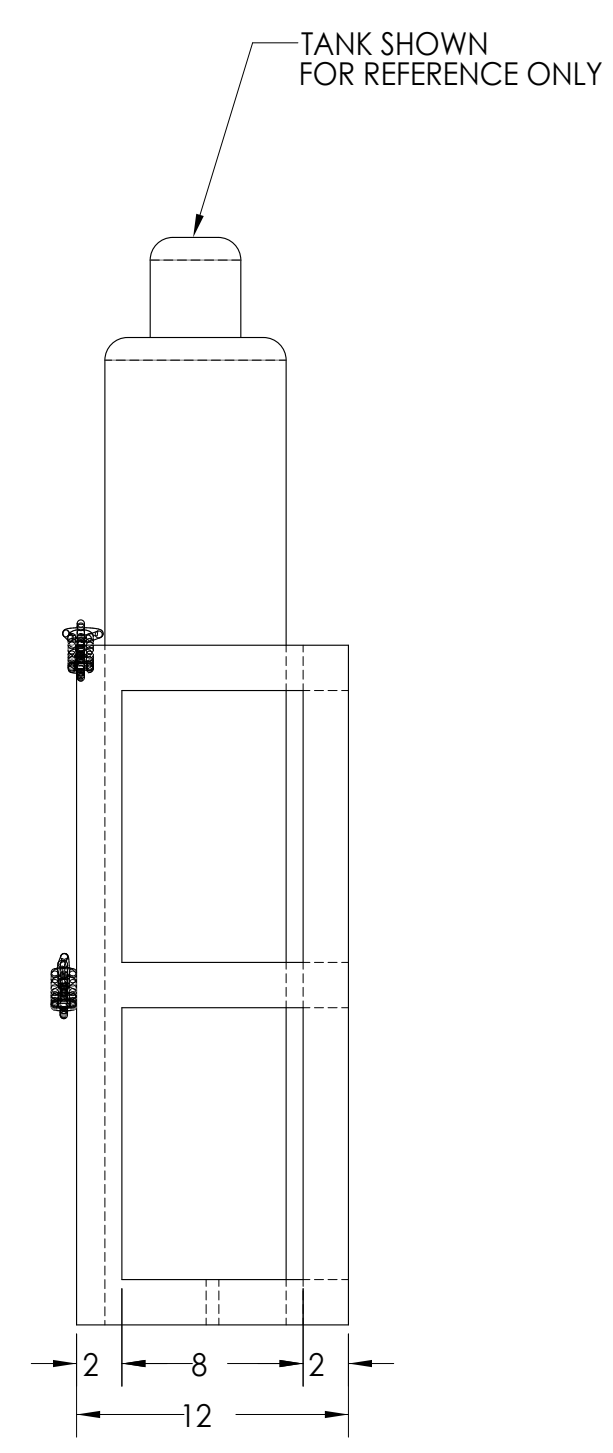

RIGHT

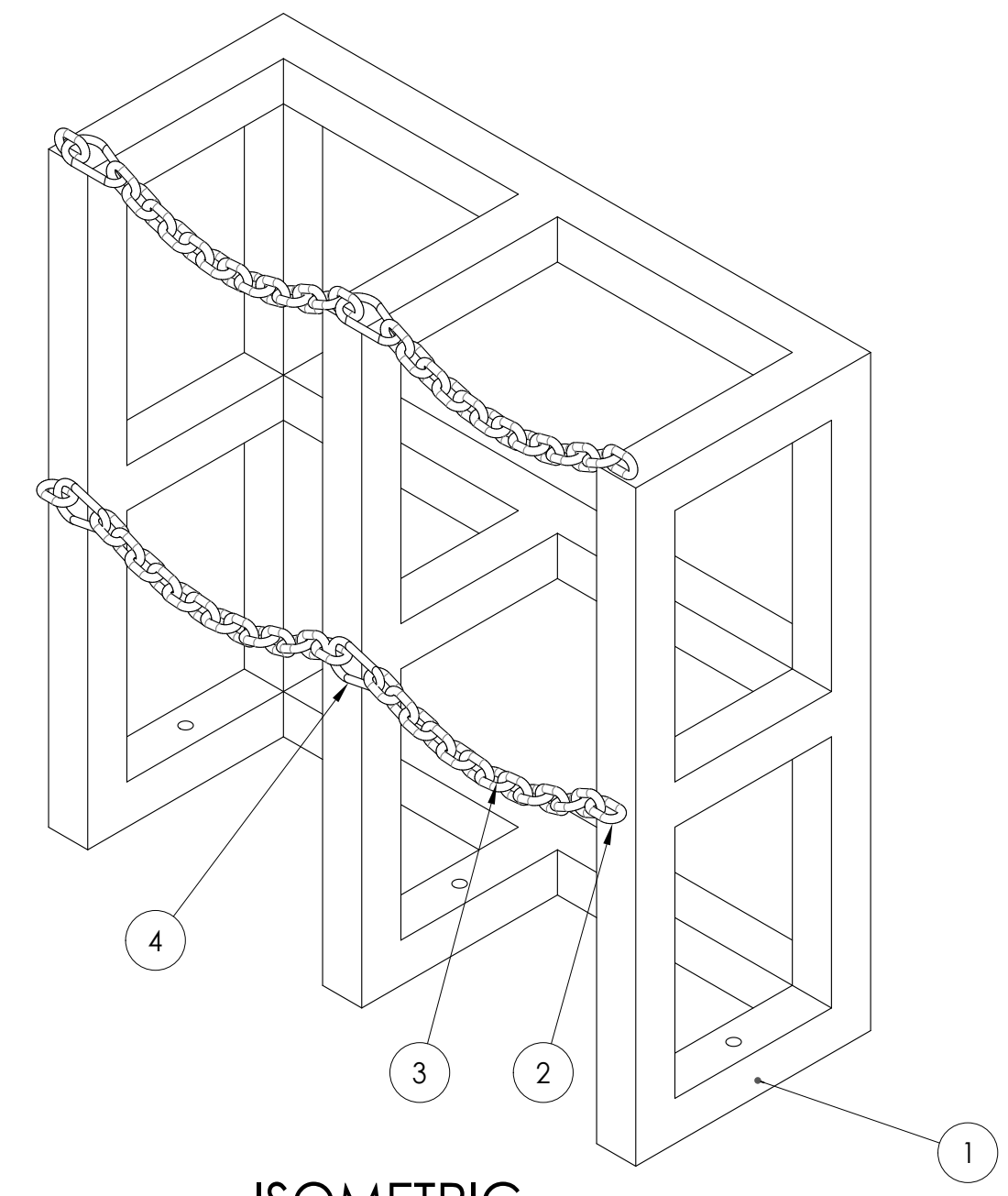

ISOMETRIC  
SCALE 1:6

ITEM NO.	MATERIAL	DESCRIPTION	QTY.
1	HSS 2" X 2" X 1/8"	HSS STEEL FRAME CUT AND WELDED TO RACK SIZE	1
2	5/16" STEEL WELDED LINK CHAIN (1,900 LBS LOAD RATING)	5/16" SINGLE WELDED LINK WELDED TO RACK FRAME	6
3	5/16" STEEL WELDED LINK CHAIN (1,900 LBS LOAD RATING)	5/16" STEEL WELDED LINK CHAIN CUT TO SIZE	4
4	5/16" STEEL CARABINER HOOK (520 LBS LOAD RATING)	5/16" STEEL CARABINER	4

**PROPRIETARY AND CONFIDENTIAL**  
THE INFORMATION CONTAINED IN THIS DRAWING IS THE SOLE PROPERTY OF <INSERT COMPANY NAME HERE>. ANY REPRODUCTION IN PART OR AS A WHOLE WITHOUT THE WRITTEN PERMISSION OF <INSERT COMPANY NAME HERE> IS PROHIBITED.

		UNLESS OTHERWISE SPECIFIED:		NAME	DATE
		DIMENSIONS ARE IN INCHES TOLERANCES: FRACTIONAL ± ANGULAR: MACH ± BEND ± TWO PLACE DECIMAL ± THREE PLACE DECIMAL ±		DRAWN	
INTERPRET GEOMETRIC TOLERANCING PER: MATERIAL		FINISH		TITLE: <b>MODEL 1D2W</b>	
NEXT ASSY	USED ON	COMMENTS:		SIZE <b>C</b>	DWG. NO. <b>1D2W</b>
APPLICATION		DO NOT SCALE DRAWING		SCALE: 1:8	WEIGHT: SHEET 1 OF 1