

# Installation Manual for



## Biscayne, Sanibel, St. Augustine All Single and Dual Decorative Steel Driveway Gate Models



3121 Hartsfield Road • Tallahassee, Florida, USA 32303  
Telephone GTO Sales: 1-800-543-GATE (4283) or (850) 575-0176 • Fax (850) 575-8912  
or GTO Technical Service: 1-800-543-1236 or (850) 575-4144 • Fax (850) 575-8950

**For more information on Mighty Mule's full line of Automatic Gate Openers and Access Controls visit our website at [www.mightymule.com](http://www.mightymule.com)**

**IMPORTANT:** Before digging the holes for your installation, be sure to contact the appropriate utility companies and request that they mark the locations of all pipes, gas lines, electric, cable tv, etc. This will ensure your safety and prevent you from damaging any of these utility lines.

EZGATEINST  
rev - 09/23/09

## Conversion Chart

### Converting Metric Units to English Equivalents

When You Know	Multiply By	To Find	Symbol
centimeters	0.3937	inches	in. (or ")
meters	3.2808	feet	ft. (or')
kilograms	2.2046	pounds	lb. (or #)

### Converting English Units to Metric Equivalents

When You Know	Multiply By	To Find	Symbol
inches	2.5400	centimeters	cm
feet	0.3048	meters	m
pounds	0.4535	kilograms	kg

### Converting Temperature

deg. Celsius	$(^{\circ}\text{C} \times 1.8) + 32$	deg. Fahrenheit	$^{\circ}\text{F}$
deg. Fahrenheit	$(^{\circ}\text{F} - 32) \div 1.8$	deg. Celsius	$^{\circ}\text{C}$

IMPORTANT: Before digging the holes for your installation, be sure to contact the appropriate utility companies and request that they mark the locations of all pipes, gas lines, electric, cable tv, etc. This will ensure your safety and prevent you from damaging any of these utility lines.

## FOR YOUR RECORDS

Please record the date and place of purchase in the spaces provided below.  
Refer to this information when calling GTO for service or assistance with your gate.

Date of Purchase \_\_\_\_\_

Place of Purchase \_\_\_\_\_

***Remember to keep all receipts for proof of purchase.***

# Table of Contents

**KEEP THESE INSTRUCTIONS FOR FUTURE REFERENCE**

<b>Units and Standards Conversion Chart</b> -----	<b>inside cover</b>
Parts List -----	page 4
Tools You Will Need -----	page 5
Technical Specifications -----	page 6
Planning Your Gate Layout -----	page 7
Single Gate Installation Overview -----	page 9
Dual Gate Installation Overview -----	page 10
Sloping Driveway Installation -----	page 11
Marking Post Locations -----	page 11
Digging Holes and Mixing Concrete -----	page 12
Setting The Posts -----	page 13
Attaching The Hinge Plates -----	page 15
Hanging The Gate and Final Steps -----	page 16
Maintenance and Troubleshooting -----	page 17
<b>Automating Your Gate</b> -----	<b>page 18</b>
<b>Optional Gate Accessories</b> -----	<b>page 19</b>

# Parts List - Gate and Mounting Hardware

## Gate Panel(s)

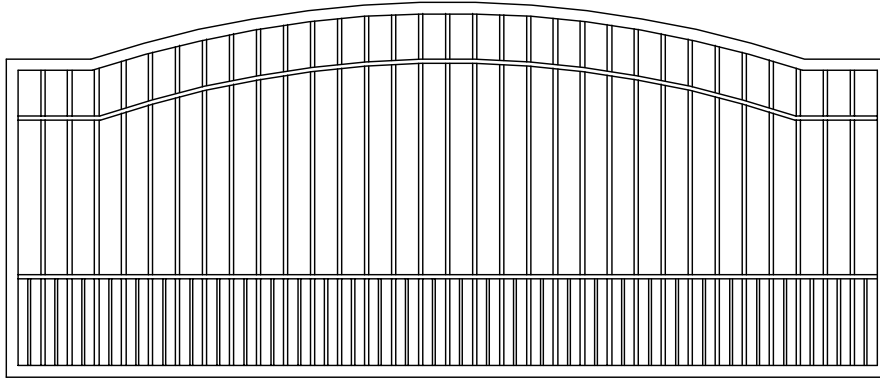

### Hinge Bolts

Single Gates - 2  
Dual Gates - 4

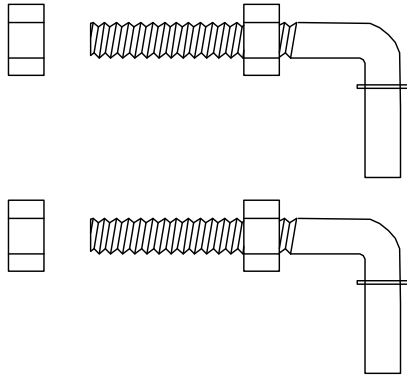

### Ball Caps (2)



### Gate Posts (2)

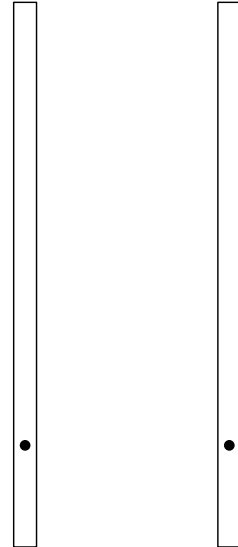

### Hinge Plates

Single Gates - 2  
Dual Gates - 4

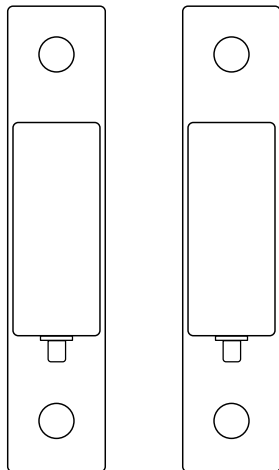

### Touch-up Paint (1)



### 1/2" x 5" Bolts

Single Gates - 4  
Dual Gates - 8



### 1/2" Flange Nuts

Single Gates - 4  
Dual Gates - 8

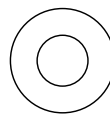

### 1/2" Washers

Single Gates - 4  
Dual Gates - 8

## Tools You Will Need



- ❶ Box beam level
- ❷ Hoe to mix concrete
- ❸ 2 Stakes
- ❹ Mallet
- ❺ Water bucket
- ❻ Post hole digger
- ❼ Tape measure
- ❽ At least 10 bags of quick set concrete (5 per post)
- ❾ Can of Spray Paint
- ❿ Shovel
- ⓫ Wrenches 5/8", 9/16"
- ⓬ String line
- ⓭ Line Level
- ⓮ Wheelbarrow
- ⓯ Grease Gun

# Technical Specifications

## Steel Gate Specifications

**Frame Ends:** 2 x 2 x 11 Gauge Steel Tubing  
**Frame Tops and Bottoms:** 2 x 2 x 14 Gauge Steel Tubing  
**Rails:** 1 1/2 x 3/4 x 1/8 Punched Steel Channel  
**Pickets:** 3/4 x 3/4 x 16 Gauge Steel Tubing  
**Finish:** Powder Coated Black

## Gate Dimensions & Weights

### Biscayne

Type	Length	Approximate Weight of Each Panel
Single	10 ft	150 lbs
Single	12 ft	180 lbs
Double	12 ft	100 lbs
Double	14 ft	120 lbs
Double	16 ft	140 lbs

### Sanibel

Type	Length	Approximate Weight of Each Panel
Single	10 ft	130 lbs
Single	12 ft	156 lbs
Double	12 ft	85 lbs
Double	14 ft	100 lbs
Double	16 ft	115 lbs

### St. Augustine

Type	Length	Approximate Weight of Each Panel
Single	10 ft	142 lbs
Single	12 ft	170 lbs
Double	12 ft	90 lbs
Double	14 ft	105 lbs
Double	16 ft	120 lbs

## Gate Post Dimensions and Weights

Type	Height	Widths, Thickness and Weight	
Single	96" both posts	<b>Hinge Post</b> 4"x4"x1/4" - 100lbs	<b>Passive Post</b> 4"x4"x1/8" - 80lbs
Double	96" both posts	<b>1st Hinge Post</b> 4"x4"x1/4" - 100lbs	<b>2nd Hinge Post</b> 4"x4"x1/4" - 100lbs

Post without ball cap is 96" in height  
 These specifications are subject to change without notice.

# Planning Your Gate Layout

Determine where you want to install your gate. There are many factors to consider before you install your gate. Area of driveway, distance from road, conditions in and around driveway, type of vehicles entering property etc. Also be sure to factor in the distance for a keypad if installing a keypad mounting post. Some of the terms that will be used in these instructions are defined to the right.

**Pocket** - The space between the gate and the turn into your driveway.

**Squareness** - The gate's angle to the driveway. 90°/perpendicular to the driveway is ideal.

**Pull-to-Open / Push-to-Open** - If the gate swings in or out from the property. Pull-to-Open is the most desirable but not always possible.

**Handing** - Which side of driveway to which gate will open. Depends which side of gate has the hinges.

## The Pocket

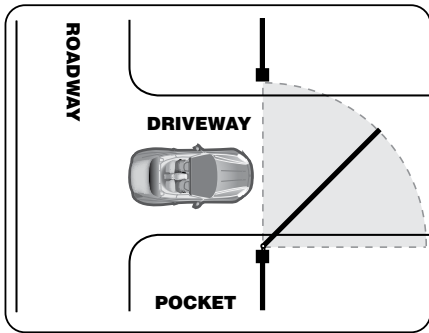

**BEST OPTION** - Allows you to pull off road while you wait for gate to open.

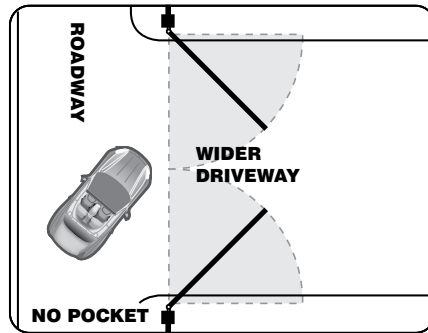

**IMPROVED OPTION** - Doesn't allow a pocket, but allows larger vehicles (a moving van, etc.) to make the turn into the drive.

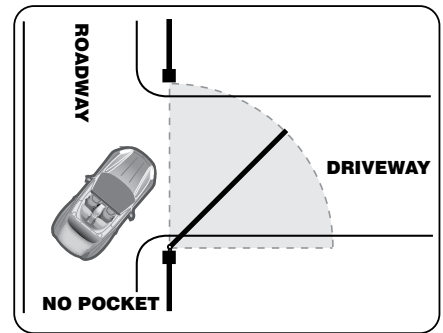

**WORST OPTION** - Prevents you from pulling off road as you wait for the gate. Prevents larger vehicles from making the turn in.

## Squareness

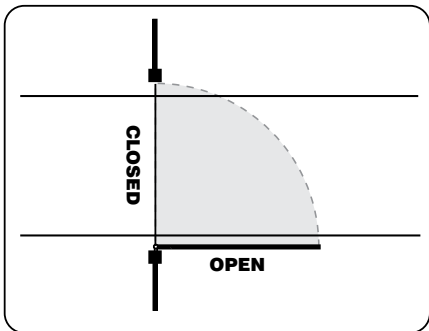

**CORRECT** - Gate is perpendicular to drive path.

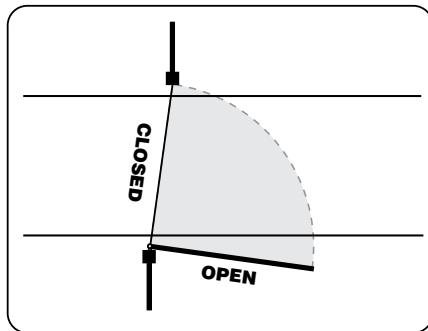

**INCORRECT** - Gate is not perpendicular to drive path.

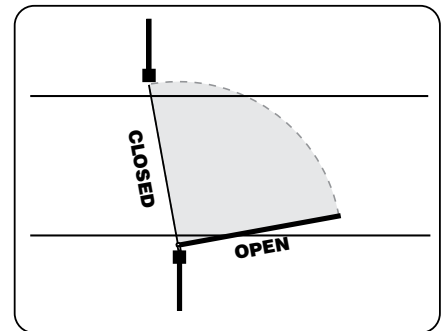

**INCORRECT** - Gate does not open all the way off of the driveway and runs the risk of being hit by a vehicle.

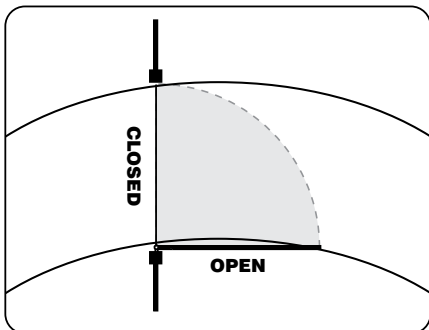

**Curved Driveways Demand Extra Care In Layout.**  
**CORRECT** - Gate is perpendicular to drive path.

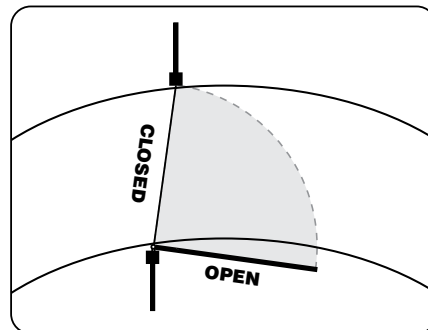

**INCORRECT** - Gate is not perpendicular to drive path.

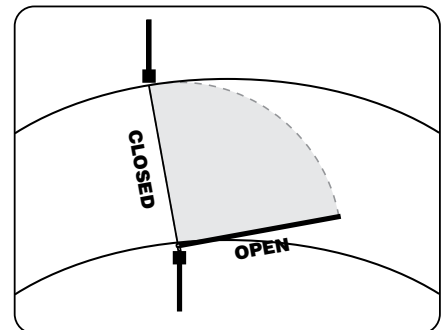

**INCORRECT** - Gate does not open all the way off of the driveway and runs the risk of being hit by a vehicle.

## Push-to-Open / Pull-to-Open

The most desirable layout for a swinging gate is to open inward. However, certain driveway conditions can make it necessary to swing a gate outward. In the first case below, a Pull-to-Open gate opens into the drive space.

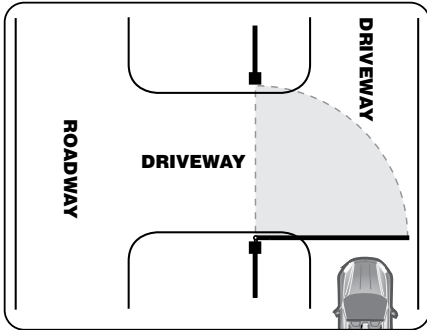

**PROBLEM (LEFT)** - Pull-to-Open gate opens into the drive space causing a dangerous situation.

**SOLUTION (RIGHT)** - Install gate as a Push-to-Open gate. Gate opens into the exit area of the driveway. This installation gives the gate plenty of clearance.

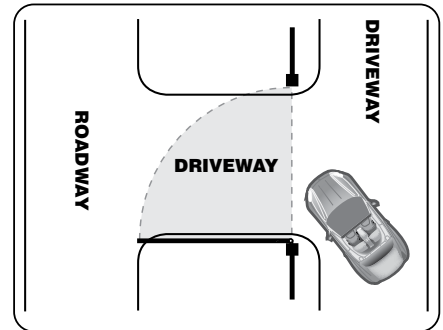

Another condition that may require you to install your gate as Push-to-Open is an inclined driveway. See illustrations below.

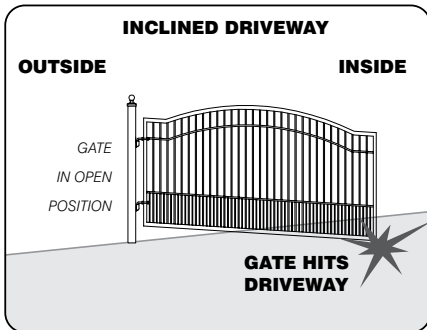

Pull-to-Open Installation

**PROBLEM (LEFT)** - If installed as a Pull-to-Open gate, the gate opens inward and hits the ground.

**SOLUTION (RIGHT)** - Install the gate as a Push-to-Open gate. This gives plenty of clearance to swing over the ground.

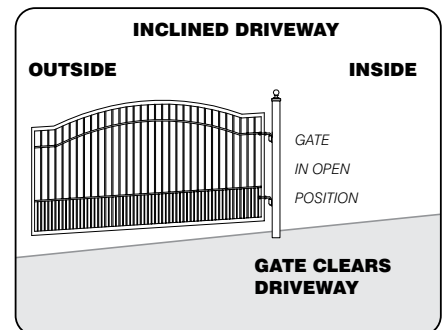

Push-to-Open Installation

## Handing Your Gate

When standing on the inside of your gate, how will your gate need to open? Look at the four examples below to help you make the right decision.

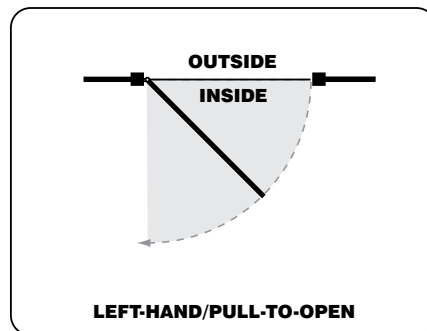

LEFT-HAND/PULL-TO-OPEN

**BEFORE BEGINNING TO INSTALL** your gate, thoroughly assess the conditions of your gate site (driveway shape, vehicles entering, space available, sloping ground) and make the necessary decisions.

1. Can I and how much space will I allow for a pocket?
2. How will I be sure that the gate is installed perpendicular to the driveway?

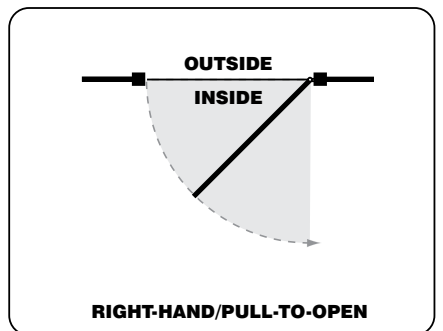

RIGHT-HAND/PULL-TO-OPEN

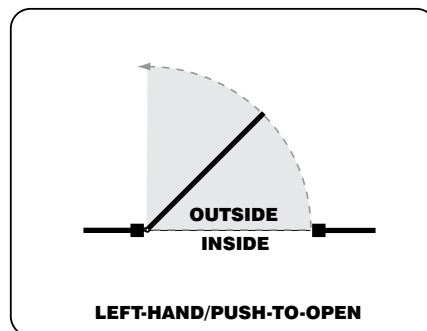

LEFT-HAND/PUSH-TO-OPEN

3. Will my gate be a Push-to-Open or a Pull-to-Open installation?

4. How will my gate open, from the left or the right of my driveway?

**FAILURE TO PLAN ACCORDINGLY CAN RESULT IN POOR INSTALLATION AND PERFORMANCE OF YOUR GATE AND ULTIMATELY COULD REQUIRE REINSTALLATION.**

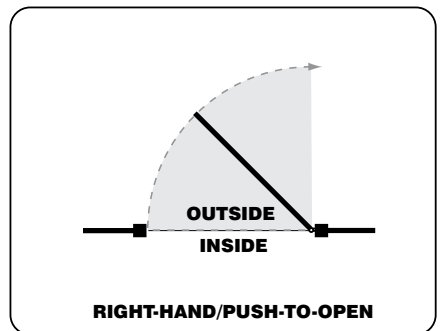

RIGHT-HAND/PUSH-TO-OPEN



# Single Gate Installation Overview

The following guidelines will help you install your gate properly resulting in smooth, trouble-free operation:

**Distance between center of gate posts:** This measurement will show you where you need to center your posts and dig the holes. Following the chart below, align and center your gate posts utilizing the yellow "E-Z Line-up" Bolts. It illustrates the required clearance needed for the gate hinge (approx. 4" clearance) and gate leading edge (approx. 2" clearance), measured from the center of the posts. **Precise measurement is crucial to successful installation of your gate.**

**Gate post height:** This measurement is the same for all gate models and is designed for a minimum of 4" clearance from the bottom of the gate and the highest crowning point on the driveway or curb.

**Depth of post hole:** Approximately 36" which will give the gate 4" clearance above the driveway at the flattest part

Driveway Width	Single Gate Size	Distance Between Center of Gate Posts		
		Sanibel	St. Augustine	Biscayne
Up to 9' 6" (114")	10' (120")	10' 9" (129")	10' 6" (126")	10' 9" (129")
9' 7" - 11' 9" (115" - 141")	12' (144")	12' 9" (153")	12' 9" (153")	12' 9" (153")

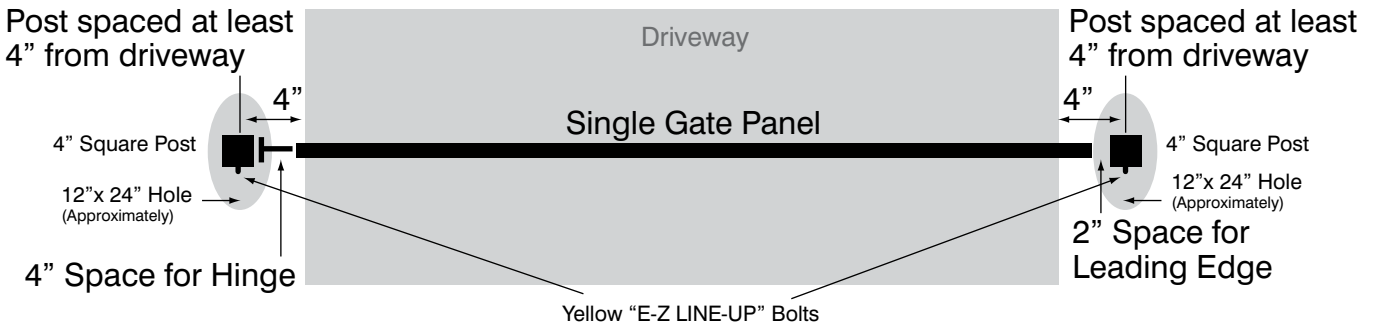

## Horizontal Dimensions

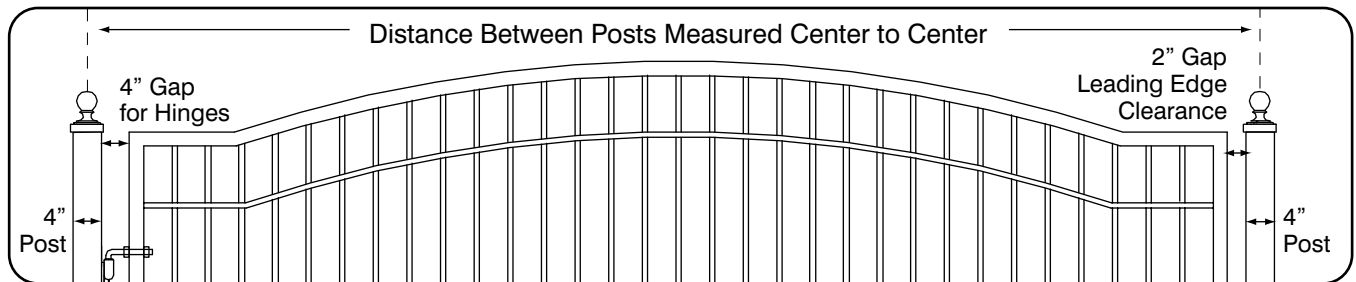

## Vertical Dimensions

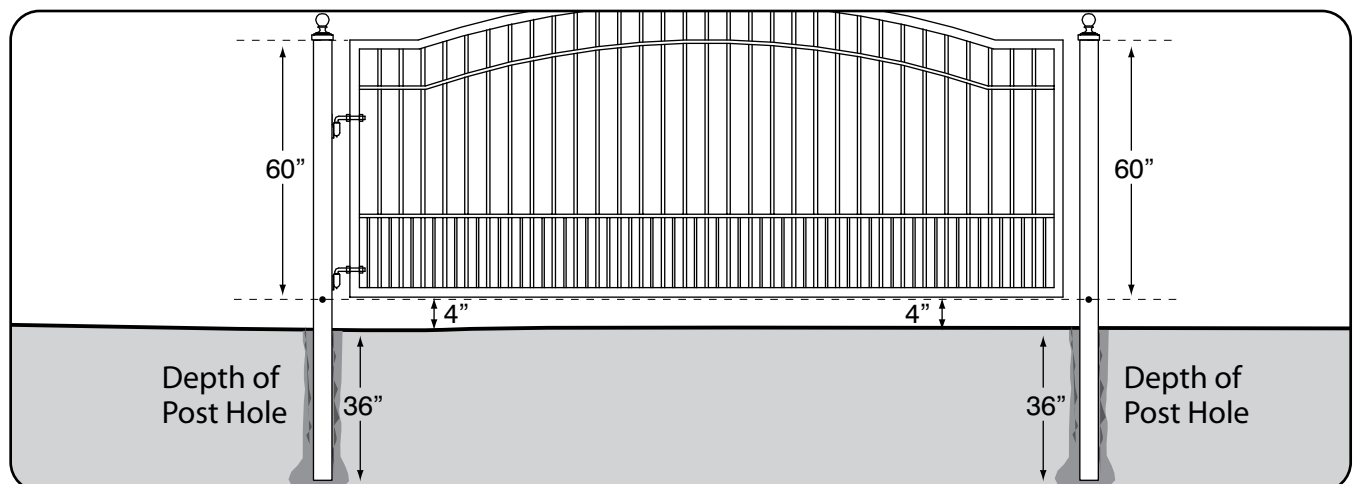

# Dual Gate Installation Overview

The following guidelines will help you install your gate properly resulting in smooth, trouble-free operation:

**Distance between center of gate posts:** This measurement will show you where you need to center your posts and dig the holes for your posts. Following the chart below, align and center your gate posts utilizing the yellow "E-Z Line-up" Bolts. It illustrates the required clearance needed for the gate hinge (approx. 4" clearance), and the space between the two gate panels (approx. 2" clearance) measured from the center of the posts. **Precise measurement is crucial to successful installation of your gate.**

**Gate post height:** This measurement is the same for all gate models and is designed for a minimum of 4" clearance from the bottom of the gate and the highest crowning point on the driveway or curb.

**Depth of post hole:** Approximately 36" which will give the gate 4" clearance above the driveway at the highest part

Driveway Width	Dual Gate Size	Distance Between Center of Gate Posts		
		Sanibel	St. Augustine	Biscayne
Up to 11' 6" (138")	12' (144")	13' 1" (157")	12' 6" (150")	13' 1" (157")
11' 7" - 13' 11" (139" - 167")	14' (168")	15' 1" (181")	14' 11" (179")	15' 1" (181")
13' 11" - 16' 1" (167" - 193")	16' (192")	17' 1" (205")	17' 3" (207")	17' 1" (205")

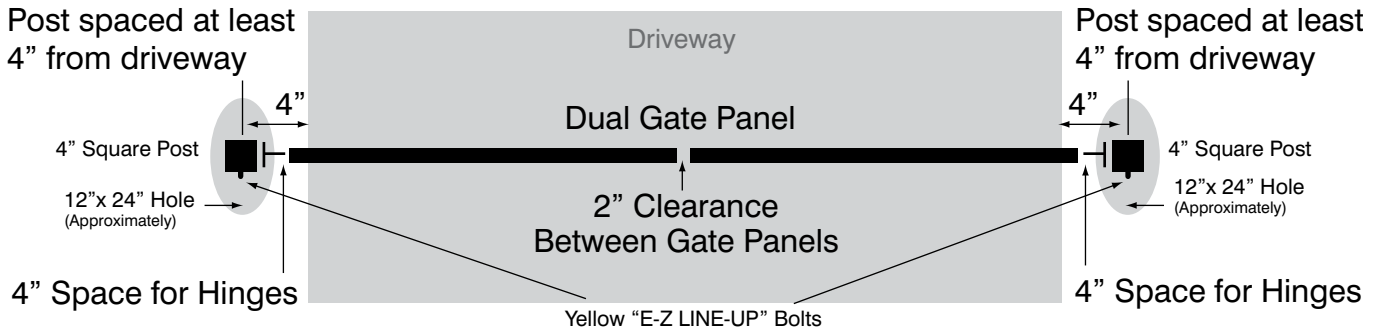

## Horizontal Dimensions

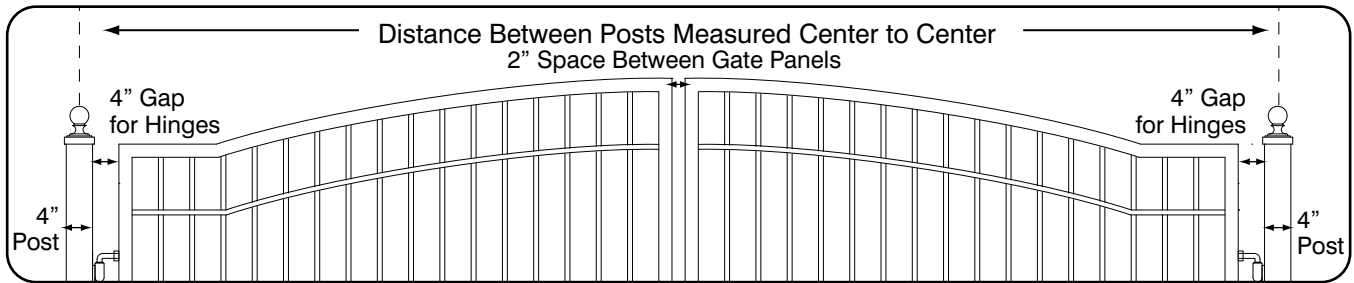

## Vertical Dimensions

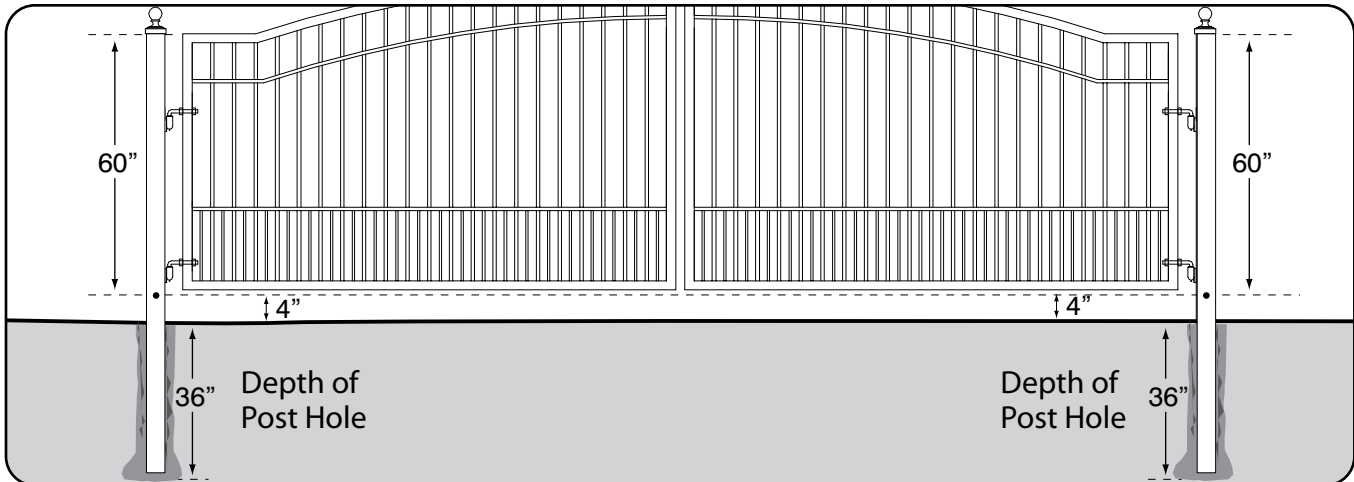

## Sloping Driveway Installation

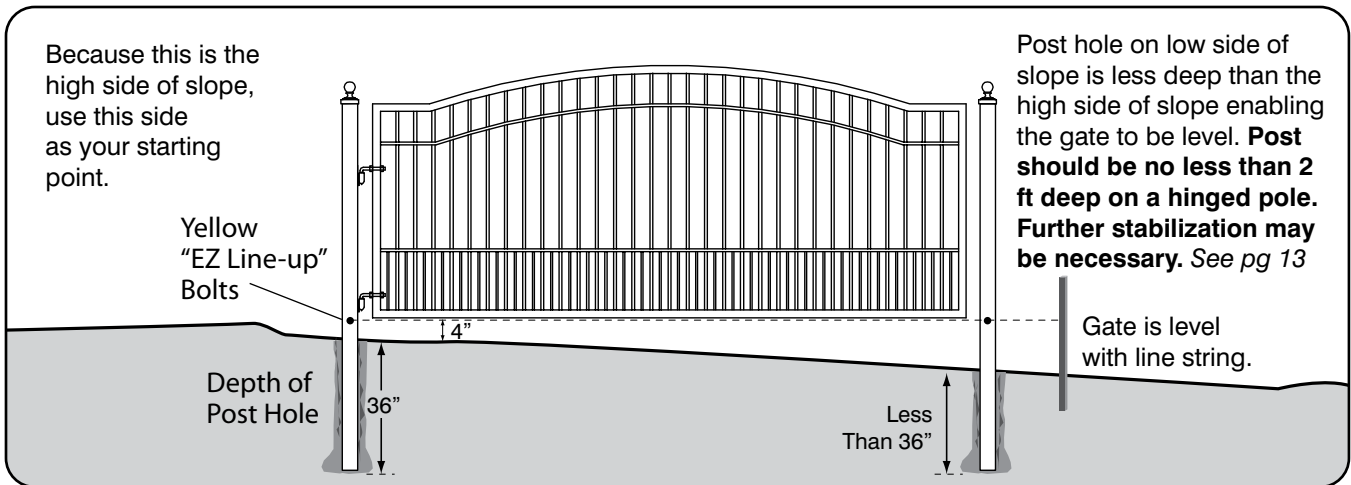

## Marking Post Locations

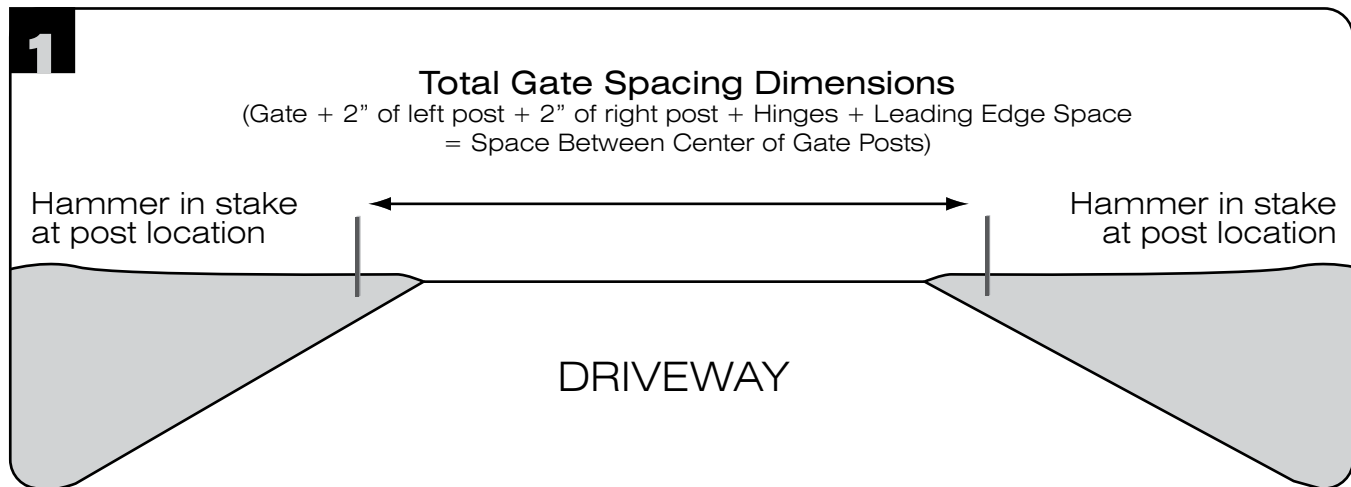

After deciding on the best gate layout, measure out on the ground the length of your gate's dimensions (see pages 9-10) Take the stakes and, using a mallet, drive the stakes into the ground at the center point of where each post will be located.

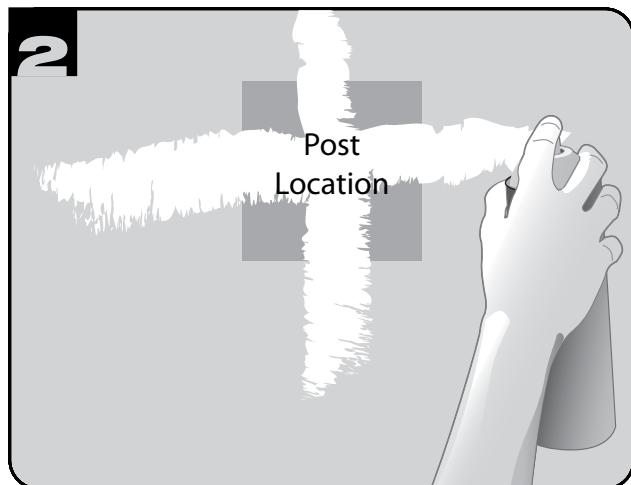

Next, use the paint to mark the ground with a crisscross to denote the gate post location.

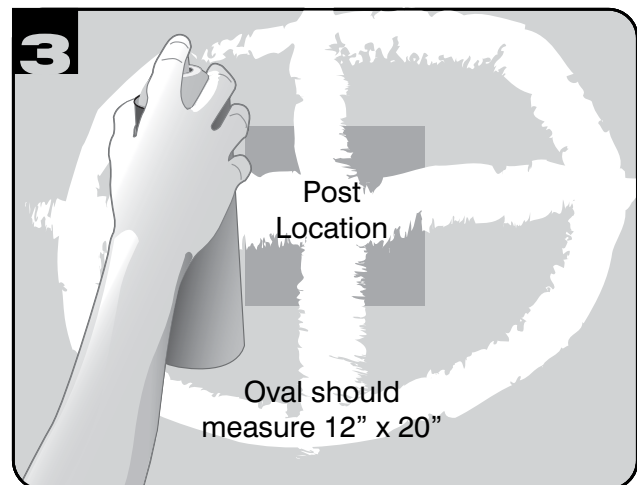

Now paint a 12" x 20" oval that will be the size of the hole you dig. Repeat steps 2 and 3 for the second post.

# Digging Holes and Mixing Concrete

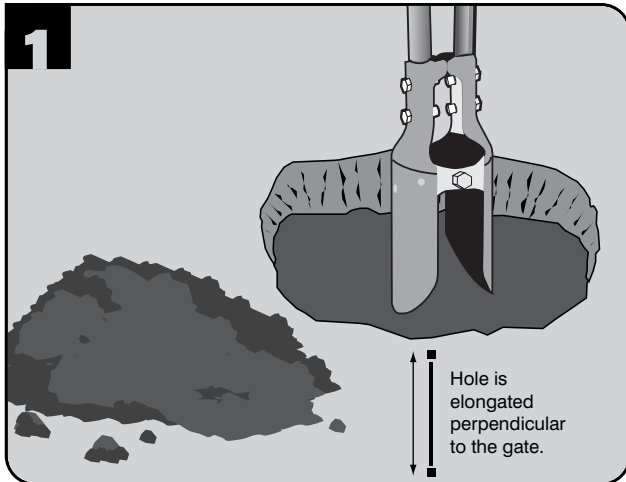

Use post hole digger to dig the holes. Do not make holes perfectly round to help prevent posts from twisting after time. If ground is flat, holes should be approx. 36" deep.

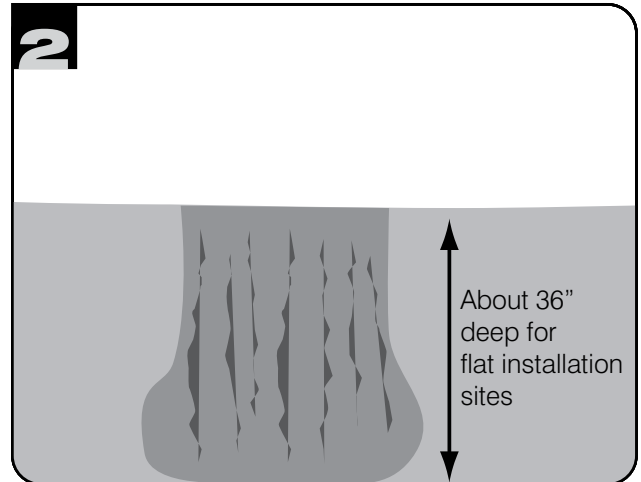

If gate installation area slopes, use the post hole at the high point as your starting guide. See pages 9 and 10. Be sure to dig both holes before you begin to mix the concrete.

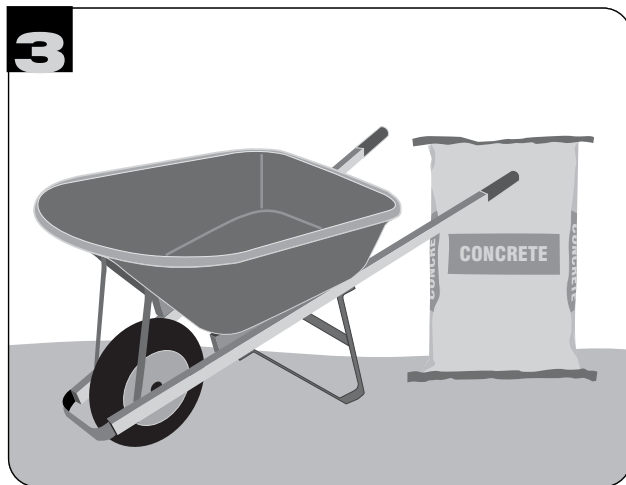

Mix the concrete one bag at a time in a wheelbarrow following the instructions on the concrete bag.

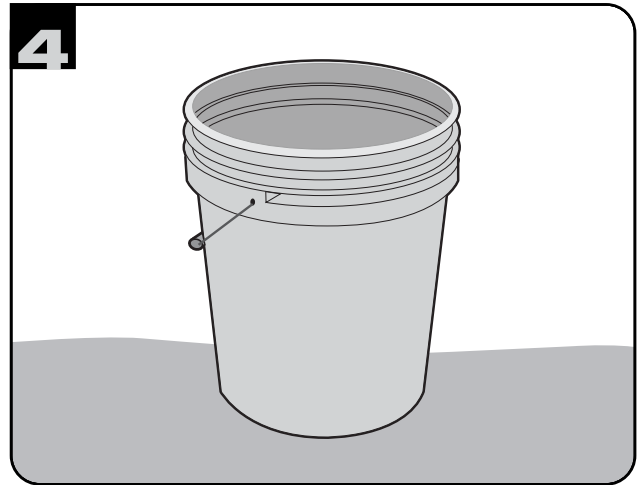

Add water incrementally using a bucket or a hose.



Use a hoe or other tool suitable for mixing the concrete in the wheelbarrow.

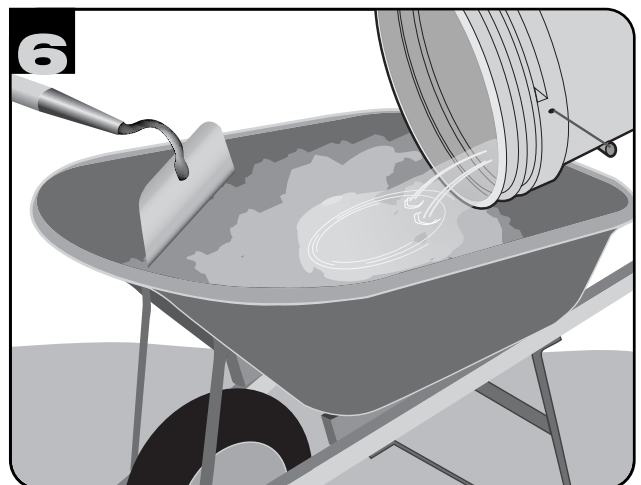

A stiff mix is necessary for post to stay by itself while concrete sets. If mix is too liquid, posts will need to be held in place until the concrete sets.

# Setting The Posts

## Special Considerations

Digging the hole with a wider bottom will help to reinforce the post because the concrete will be less likely to move in the dirt.

### Loose Dirt or Sand

Steel rebar or pipe reinforcement may be necessary to stabilize the posts in the ground. Consult your local home center store.

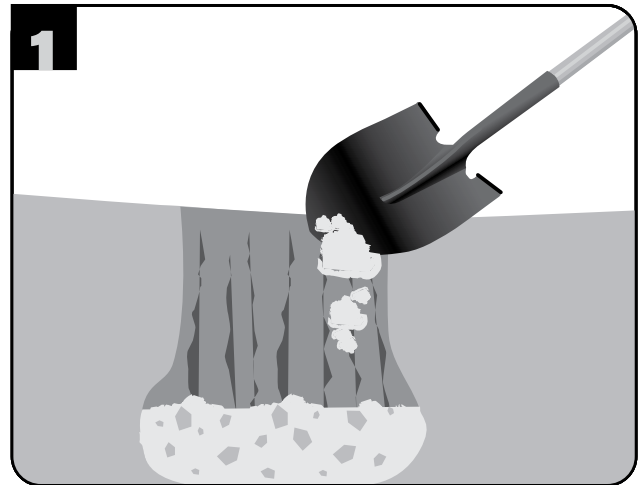
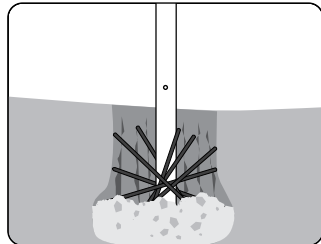

Start with a base of concrete approximately 5-6 inches deep before putting the post in the hole.

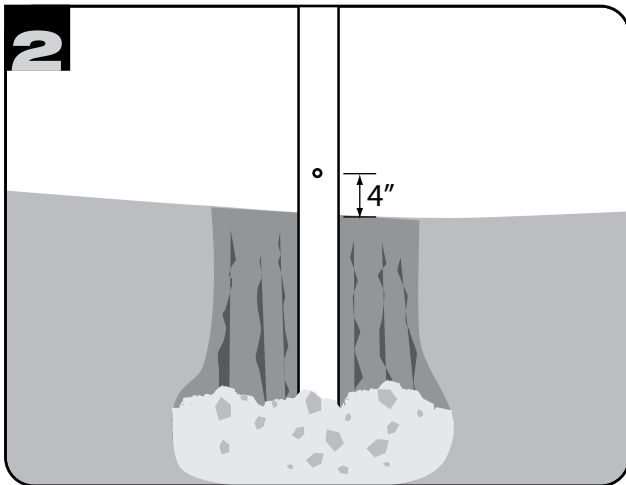

Next, place the post in the hole that is on the highest side of the driveway (if applicable) so that the leveling indicator is at least 4 inches above ground.

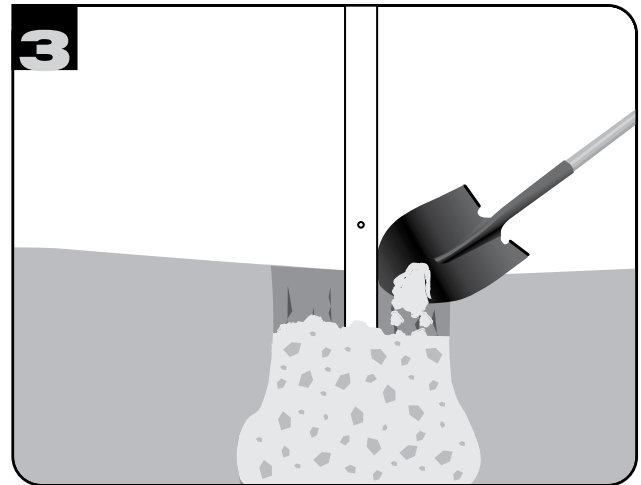

Fill the remainder of the hole by alternating the concrete around the four sides of the post so it stays centered.

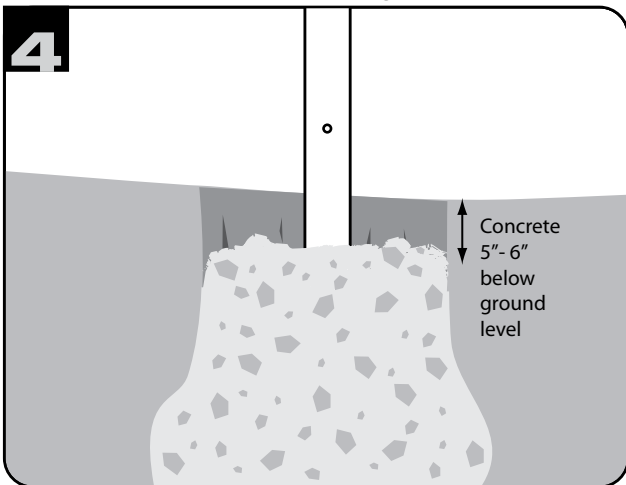

Leave the concrete 5-6 inches below the level of the flat ground. After the concrete dries you can fill the rest in with dirt so that grass can grow over the concrete.

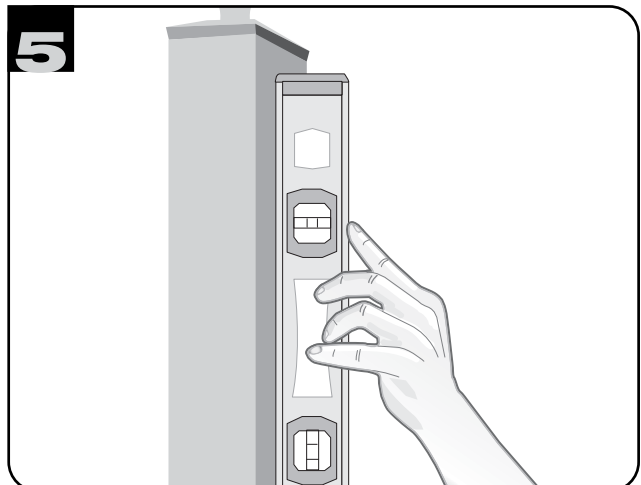

**IMPORTANT:** Check to be sure that the post is plumb by checking each side with a standard level. Adjust as necessary to achieve plumbness.

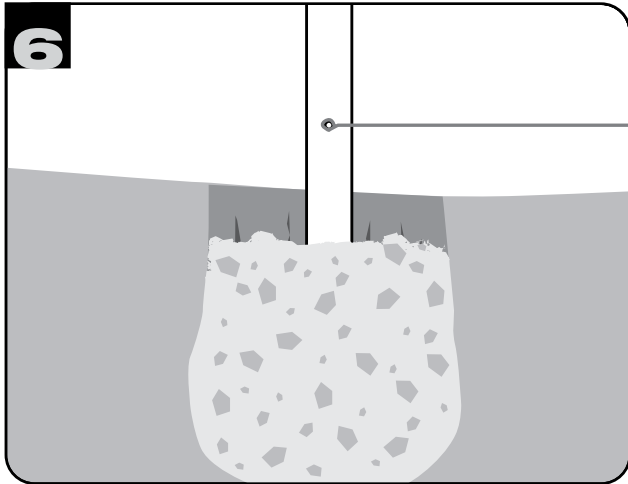

Tie the line string to the level indicator on the higher or first post and then tie the string to the center of one of the stakes.

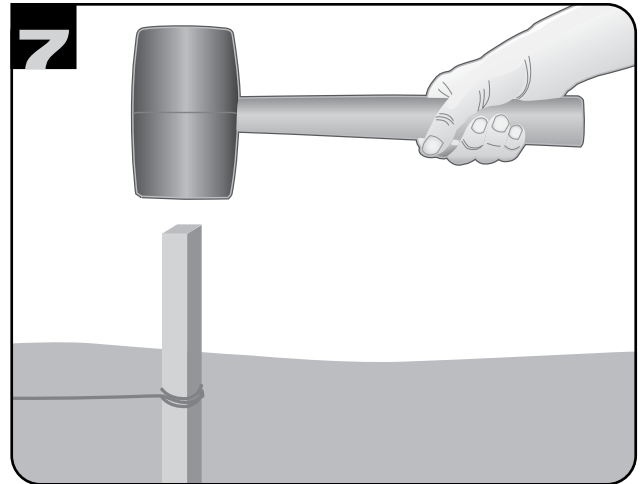

Drive the stake into the ground just beyond the lower or second hole until the string appears to be level with the ground.

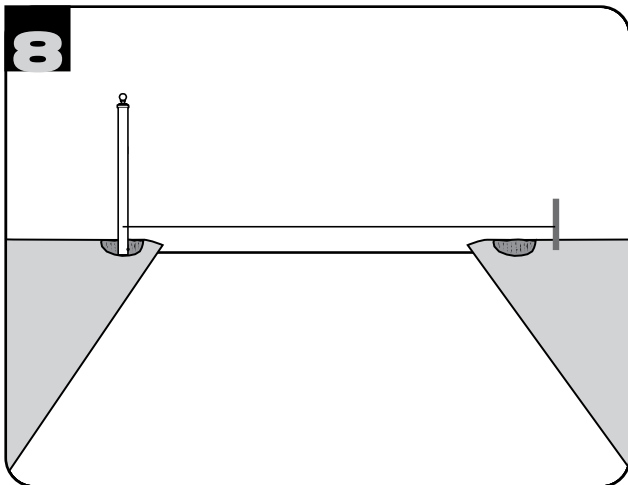

The string line should look like this and be taut from the post to the stake before performing the next step.

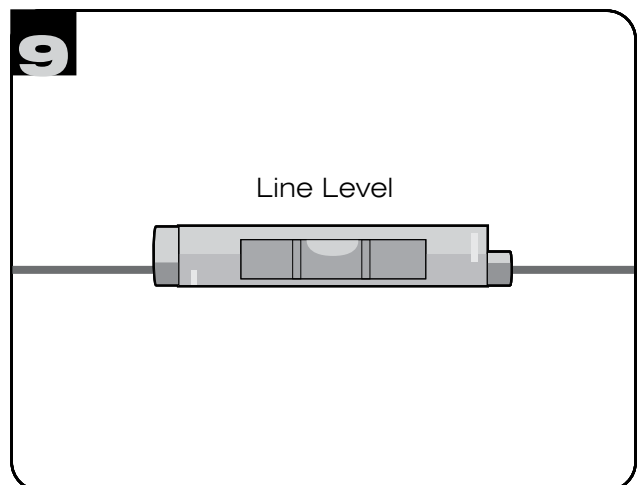

Hook the line level in the center and be sure your string is level before continuing to the next step.

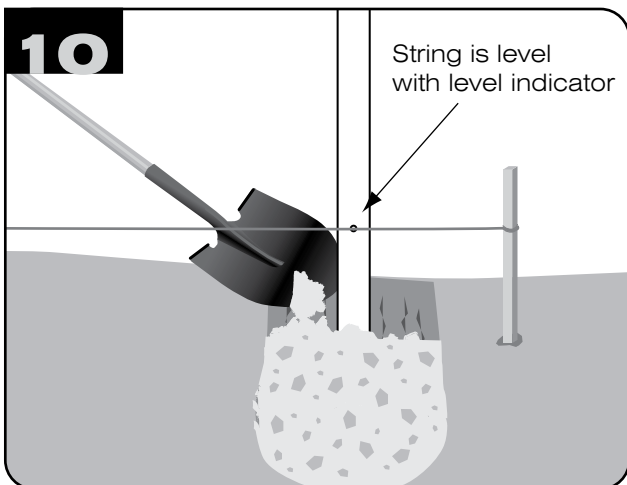

Fill second hole with concrete, adjust post so the level indicator is level with the string, measure distance between posts and adjust post to achieve the required post spacing.

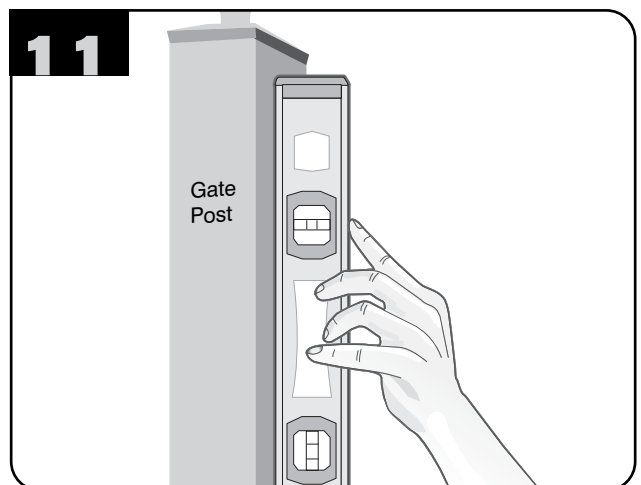

**IMPORTANT:** Check to be sure that the post is plumb by checking each side with a standard level. Adjust as necessary to achieve plumbness.

# Attaching The Hinge Plates

## **IMPORTANT: Allow Concrete to Set for 24 Hours before starting next step**

Before continuing with the next steps to your gate installation, allow your concrete to set for at least 24 hours (or according to the cement manufacturer's recommendations). This will ensure that your posts are installed in a solid concrete base and prevent any movement of the posts that could jeopardize the installation or cause otherwise harmful safety issues.

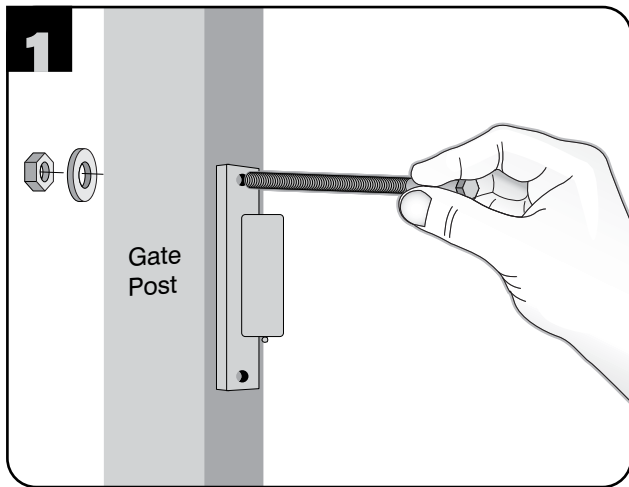

Secure the hinge plates to the gate post with the bolts and nuts included in the hardware bag. NOTE: Post holes are elongated for maximum adjustability during installation.

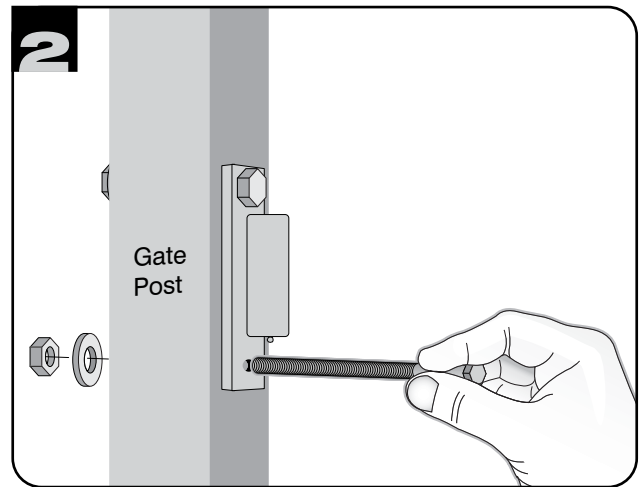

Insert bolts through top and bottom holes and secure with a nut and washer. Repeat for bottom hinge plate(s).

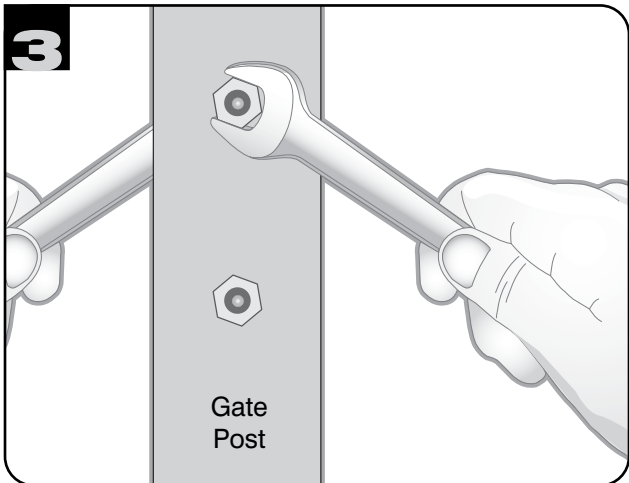

Once the bolts have been tightened by hand, secure them with a wrench on one side while holding with a wrench on the other side. Do not overtighten the bolts.

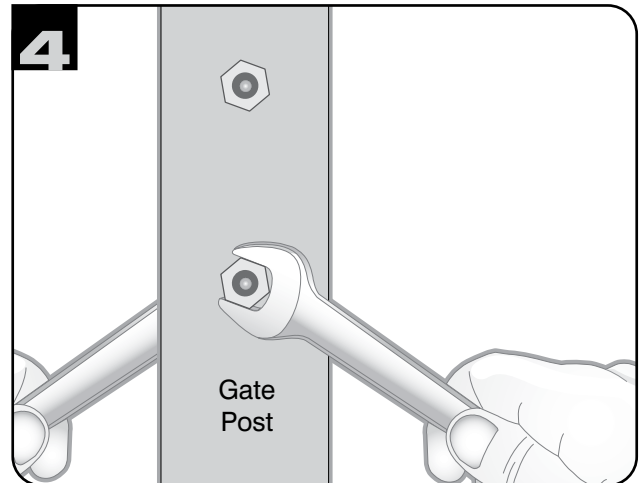

Do the same for both hinge plates or 4 hinge plates if installing a dual gate. Do not overtighten the bolts.

# Hanging The Gate and Final Steps

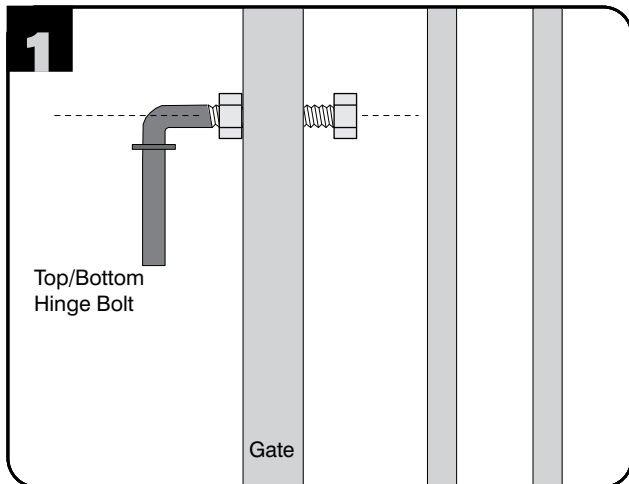

Attach one hinge bolt to the top of the gate by inserting through the hole on the gate and fastening a nut on the bolt. Repeat this step for the bottom of the gate.

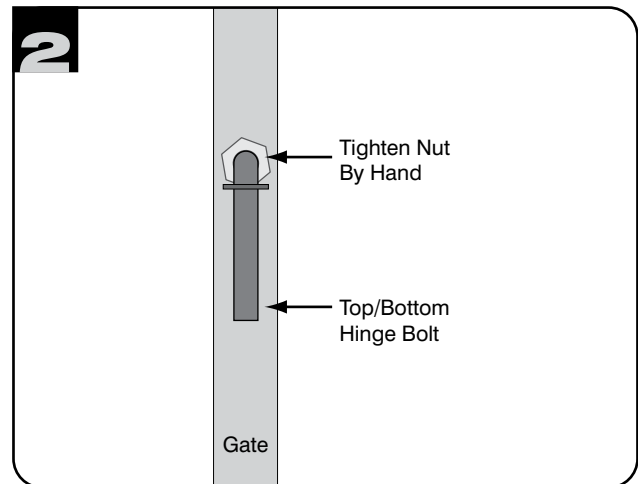

Tighten nuts by hand. **TIP:** A slightly loose hinge bolt provides ease and flexibility when dropping the hinge bolt into the hinge plate.

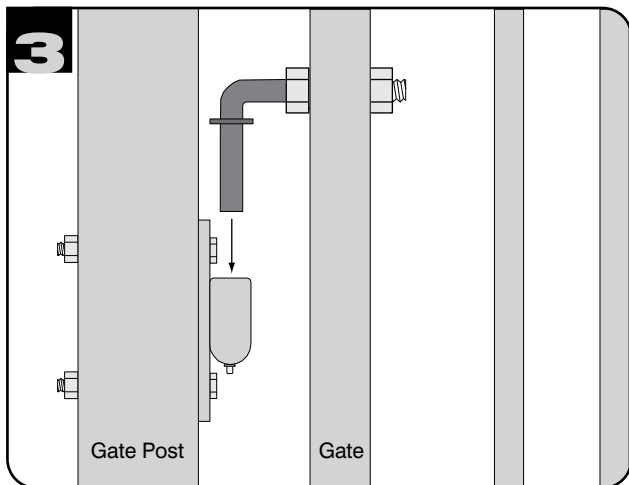

Lower the gates top and bottom hinge bolts into the hinge plates located at the top and bottom of the gate post.

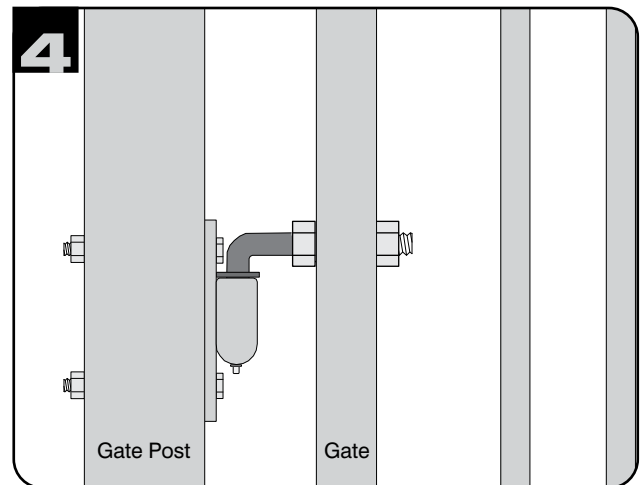

Make sure the hinge bolts fit all the way into the hinge plate as shown in the illustration.

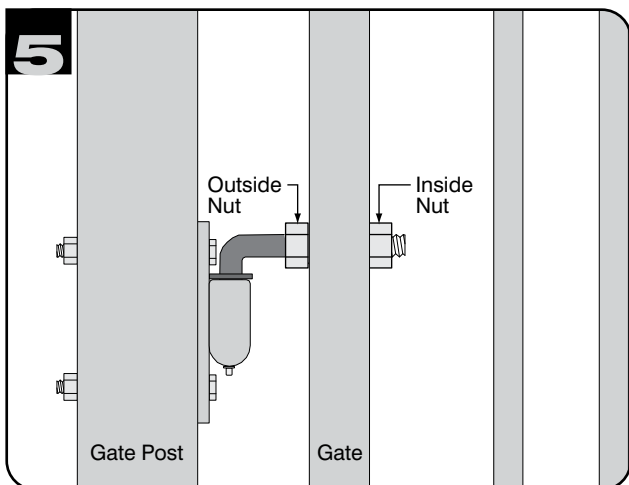

Adjust gate level by tightening and loosening the inside and outside nuts on the hinge bolts. Loosen the outside nuts to raise the gate, the inside nuts to lower the gate.

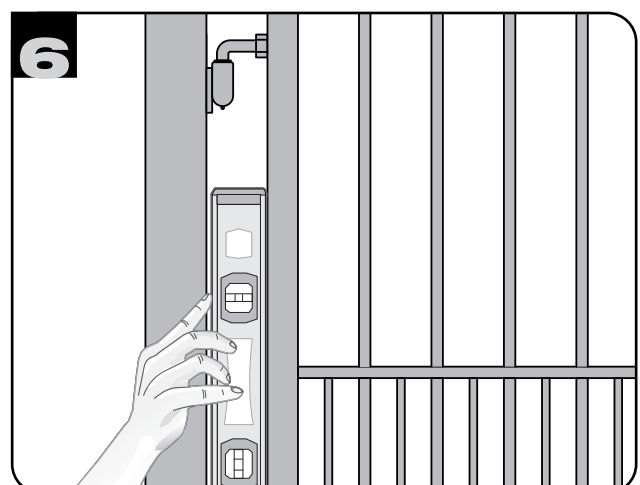

Check to be sure your gate is level. Once your gate is level, tighten all the nuts with a wrench. If installing a dual gate be sure that both panels are level with one another.



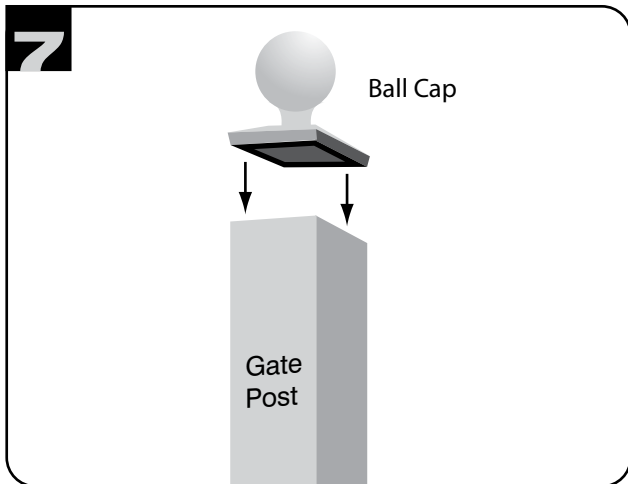

Place a ball cap on top of each of the gate posts and secure with silicone, construction adhesive or epoxy.

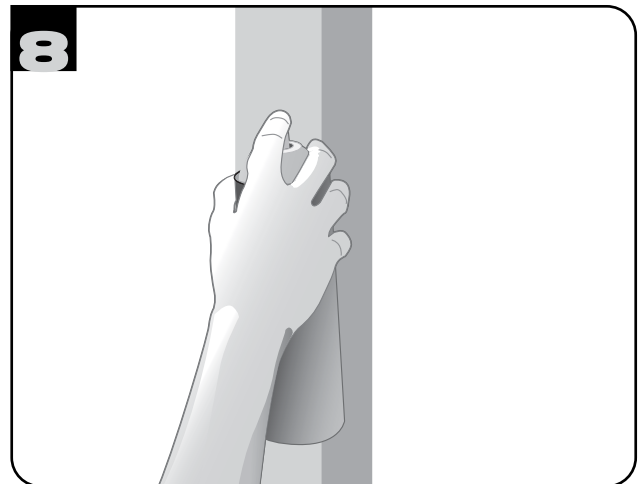

Use the black touch-up paint included to touch-up any scratches that may have occurred during the installation.

## Maintenance and Troubleshooting

If your Mighty Mule EZ Gate is not operating properly, please follow the recommended solutions below. If after trying the recommended solutions your Mighty Mule EZ Gate is still not operating properly, contact Technical Service for assistance.

- **If your gate is sagging** - Adjust the hinge bolts to lift or lower the top or bottom of the gate panel
- **If post is leaning over or is not level or plumb** - Physically move post in the direction to achieve plumbness. This may or may not be possible depending on the softness of the dirt. In extreme cases, such as poor initial installation, the post may have to be removed from the concrete and re-set in the ground with new concrete.
- **If minor rust or weeping is present** - Use the black touchup paint included with your gate to touch up spots. If the rust is more serious other products may be required to remove and inhibit the rust.
- **If your gate is squeaking** - Lubricate hinges with an all purpose lubricant and lubricate the hinge bolt grease zert with a grease gun. For maintenance lubricate the grease zerts once per year as illustrated to the right

**IMPORTANT:** Lubricate gate hinges once a year for smooth operation. Using a grease gun, place nozzle over the gate hinges grease zerts and squeeze the gun handle to insert the grease into the hinge plate.

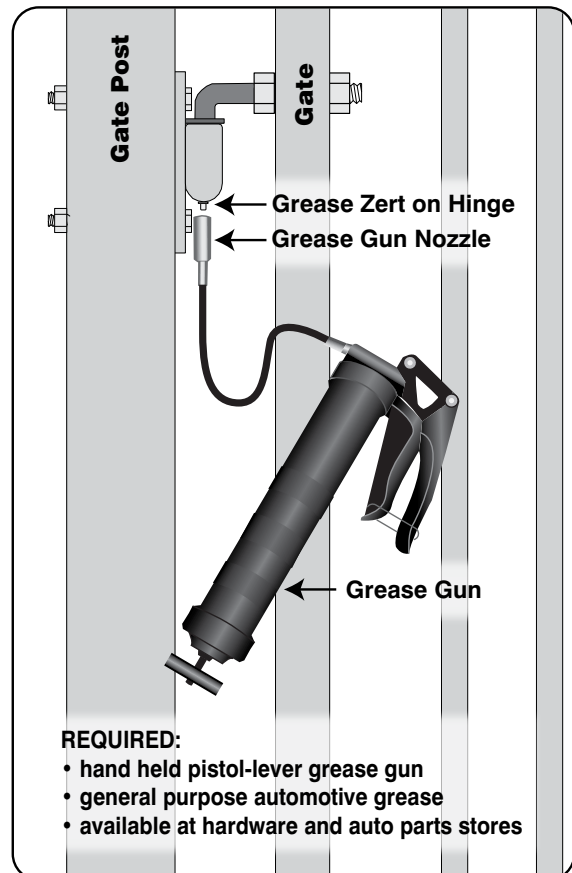

Visit the Online Troubleshooter Wizard 24 hrs/day 7 days/week at <http://support.gtoinc.com/support/troubleshooter.aspx> and open a Tech Ticket

# Automating Your Gate

## FM350 Light Duty Automatic Gate Opener

---



- Designed for gates up to 16 ft (4.9m) long or 550 lbs (249.5kg)
- Easy to install, no electrician or welding required
- Battery charge maintained by AC transformer (included), or optional Solar Charger Kit
- Designed to use 12Vdc Marine Battery (not included) provides up to 10 times more power and reserve capacity
- Preferred Solar Compatible Gate Opener because of the large battery capacity
- Works on most types of gates: chain link, tube, ornamental, wood and vinyl – not recommended for solid surface gates

## FM352 Light Duty Automatic Dual Gate Opener

---



- Designed for dual gates up to 16 ft (4.9m) long and 550 lbs (249.5kg) per leaf
- Easy to install, no electrician or welding required
- AC or Solar powered to meet the needs of 100% of the market
- Designed for optimum solar performance with 5 Watt solar panel
- Battery Back-Up - works with an automotive or marine battery (not included) which optimizes performance in cold weather
- Works on most types of gates: chain link, tube, ornamental, wood and vinyl – not recommended for solid surface gates
- Designed for gates that open into or away from the property

## FM500 Heavy Duty Automatic Gate Opener

---



- Designed for gates up to 18 ft (5.5m) long and 850 lbs (384.6)
- Easy to install low voltage system, no electrician or welding required
- 12Vdc 7 Amp/hour battery charge maintained by AC transformer (included), or optional Solar Charger Kit
- Built-in battery backup opens and closes the gate even during power outages
- Soft Start / Soft Stop feature increases life of gate hardware and opener
- Large control box with room for extra battery and accessories
- One 12 Volt, 7 Amp hour battery included
- Works on most types of gates: chain link, tube, ornamental, wood and vinyl – not recommended for solid surface gates
- Designed for gates that open into or away from the property

## FM502 Heavy Duty Automatic Dual Gate Opener

---



- Designed for dual gates up to 18 ft (5.5m) long and 850 lbs (384.6) per leaf
- Easy to install low voltage system, no electrician or welding required
- 12Vdc 7 Amp/hour battery charge maintained by AC transformer (included), or optional Solar Charger Kit
- Built-in battery backup opens and closes the gate even during power outages
- Soft Start / Soft Stop feature increases life of gate hardware and opener
- Large control box with room for extra battery and accessories
- One 12 Volt, 7 Amp hour battery included
- Works on most types of gates: chain link, tube, ornamental, wood and vinyl – not recommended for solid surface gates
- Designed for gates that open into or away from the property

## Optional Gate Accessories

**Attachment Brackets** - Allows you to easily mount an automatic gate opener or other accessory to your Mighty Mule EZ Gate.



**Positive Stop for 4" Post** - Safely stops the gate when it reaches the closed position. Can be used with or without a gate opener.

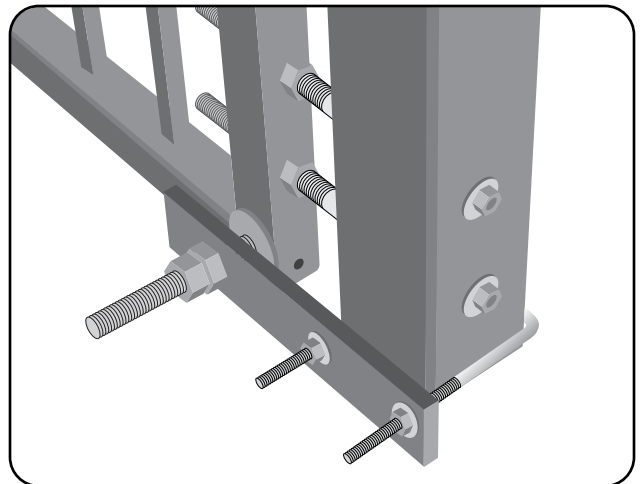



For more information on Mighty Mule's full line of Automatic Gate Openers and Access Controls visit our website at [www.mightymule.com](http://www.mightymule.com)

The **GTO, Inc. Technical Service Department** is open  
Monday – Friday 8:00 A.M. – 7:00 P.M. (Eastern Time)

**1-800-543-1236**

Fax (850) 575-8950 • Web site: [www.mightymule.com](http://www.mightymule.com)  
Visit the Online Troubleshooter Wizard 24 hrs/day 7 days/week at  
**<http://support.gtoinc.com/support/troubleshooter.aspx>**  
and open a Tech Ticket