

Catalog Number
Notes
Type

## FEATURES & SPECIFICATIONS

**INTENDED USE** — Provides a minimum of 90 minutes of illumination for the rated wattage upon loss of AC power. Ideal for applications requiring attractive unit equipment with quick installation. **Certain airborne contaminants can diminish integrity of acrylic.** [Click here for Acrylic Environmental Compatibility table, for suitable uses.](#)

**CONSTRUCTION** — White, compact, low-profile contemporary design. Engineering-grade thermoplastic housing is impact-resistant, scratch-resistant and corrosion-proof. UL94V-0 flame rating. UV-stable resin resists discoloration from natural and man-made light sources.

Two LED lamp heads with 12 series-parallel white LEDs each, provide redundant light sources to ensure emergency lighting performance. The typical life of the LED lamp is 10 years.

Dual-voltage input capability (120/277V). Edge connector on printed circuit board ensures long-term durability. Low-profile, integrated test switch/pilot light. Easily visible bright red status indicator.

Unique track-and-swivel arrangement permits full range of direction of lamp head adjustment. Universal J-box mounting pattern. Tool-less access for maintenance. Flexible conduit entry provision on top of the unit. Ceiling- or wall-mount standard.

**ELECTRICAL** — Current-limiting charger maximizes battery life and minimizes energy consumption. Provides low operating costs.

Short-circuit protection — current-limiting charger circuitry protects printed circuit board from shorts.

Thermal compensation adjusts charger output to provide optimum charge voltage relative to ambient temperature. Regulated charge voltage maintains constant-charge voltage over a wide range of line voltages. Prevents over/undercharging that shortens battery life and reduces capacity.

Filtered charger input minimizes charge voltage ripple and extends battery life.

AC/LVD reset allows battery connection before AC power is applied and prevents battery damage from deep discharge.

Single multi-color LED indicator to display two-state charging, test activation and three-state diagnostic test. Test switch provides manual activation of 30-second diagnostic testing for on-demand visual inspection. Self-diagnostic testing for 30 seconds every 30 days, 30 minute every 180 days and 90 minutes annually. Diagnostic evaluation of LED light source, AC to DC transfer, charging and battery condition.

Battery Sealed, maintenance-free nickel-cadmium battery delivers 90 minute capacity to emergency lamps. Two-state constant-current charge maximizes battery life and automatically recharges after battery discharge. Low-voltage disconnect prevents excessively deep discharge that can permanently damage the battery. Optional high-output battery available to power both local and optional LED remote lamp heads simultaneously.

**LISTINGS** — UL damp location listed standard 50-104°F (10-40°C). Meets UL 924, NFPA 101 (current Life Safety Code), NEC and OSHA illumination standards.

**WARRANTY** — 5-year limited warranty. Complete warranty terms located at [www.acuitybrands.com/CustomerResources/Terms\\_and\\_conditions.aspx](http://www.acuitybrands.com/CustomerResources/Terms_and_conditions.aspx)

Actual performance may differ as a result of end-user environment and application.

Note: Specifications subject to change without notice.



Thermoplastic Emergency Light

# ELM2 LED

LED Lamp Head  
Ni-Cad Battery



### ORDERING INFORMATION

Lead times will vary depending on options selected. Consult with your sales representative.

Example: ELM2 LED

Family	Lamp type	Housing	Options
ELM2	LED Two 1.5W/3.6V white LED	(blank) White B Black	HO High-output ni-cad battery for 6W remote capacity SD Self-diagnostics NOM Meets Mexican standards <sup>1</sup>

**Accessories:** <sup>2,3,5</sup> Order as separate catalog number.

ELA Q L0304	Single LED indoor remote head, white
ELA T Q L0304	Twin LED indoor remote head, white
ELA QWP L0304	Single LED weather-proof remote head, gray
ELA T QWP L0304	Twin LED weather-proof remote head, gray
ELA WG1	Wireguard, 15"W x 13-1/2"H x 6"D <sup>4</sup>

#### Notes

- Available in black or white. Consult factory for options.
- Also available in black. Add "B" after ELA to order black finish. Example: ELA B Q L0304.
- Only compatible with Quantum LED series. For use with self-diagnostics fixture, add SD to end of catalog number. Example: ELA Q L0304 SD.
- See spec sheet [ELA-WG](#).
- See spec sheet [ELA-Q-LED](#).

# ELM2 LED QUANTUM® Thermoplastic Emergency Light

## SPECIFICATIONS

### ELECTRICAL

#### Primary Circuit

Typical LED Life <sup>1</sup>	Supply Voltage	Max Amps	Max Watts
10 years	120	.04	1.44
	277	.03	1.44

### BATTERY

#### Ni-Cad (N)

Voltage	Shelf life <sup>2</sup>	Typical life <sup>2</sup>	Maintenance <sup>3</sup>	Optimum temperature <sup>4</sup>
3.6	3 years	7-9 yrs.	none	50-104°F (10-40°C)

- 1 Based on continuous operation. The typical life of the LED lamp is 10 years.
- 2 At 77°F (25°C).
- 3 All life safety equipment, including emergency lighting path of egress, must be maintained, serviced and tested in accordance with all National Fire Protection Association and local codes. Failure to perform the required maintenance, service or testing could jeopardize the safety of occupants and will void all warranties.
- 4 Optimum ambient temperature range where unit will provide capacity for 90 minutes. Higher and lower temperatures affect life and capacity. Consult factory for detailed information.

### REMOTE OUTPUT CAPACITY

Standard unit	Unit\ high-output battery (HO)
NA	6W

## MOUNTING

All dimensions are inches (centimeters).  
Shipping weight: 4.0 lbs. (1.8 kgs.)

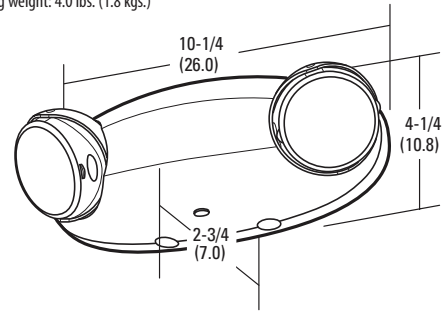

### Mounting Plate

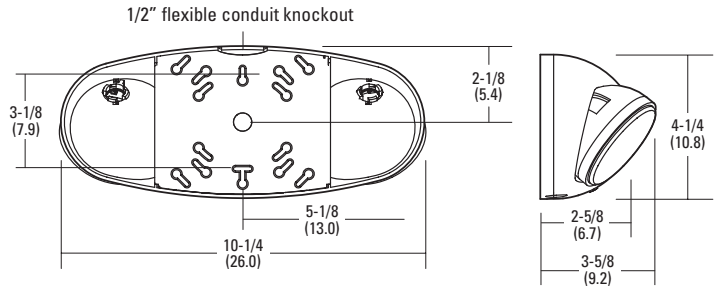

## LAMP PHOTOMETRICS

### QUANTUM LED SERIES – SINGLE COVERAGE

3W Total White LEDs

Using a single unit at a typical 7.5' mounting height delivers an average illuminance of 1.0 FC over a distance of 24' on a 3' path of egress and 18' on a 6' path of egress.

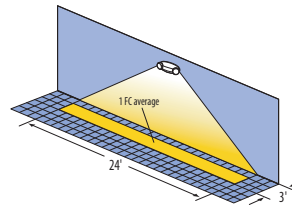

Example of single ELM2 LED unit illuminating a 3' path of egress

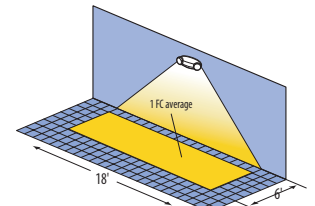

Example of single ELM2 LED unit illuminating a 6' path of egress

### QUANTUM LED SERIES – MULTIPLE COVERAGE

3W Total White LEDs

Using multiple units at a typical 7.5' mounting height delivers 25' center-to-center spacing on a 3' path of egress and 20' center-to-center spacing on a 6' path of egress.

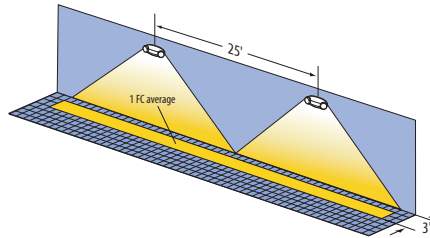

Example of multiple ELM2 LED units illuminating a 3' path of egress

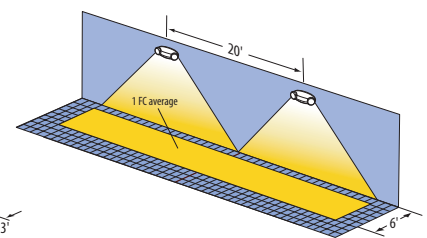

Example of multiple ELM2 LED units illuminating a 6' path of egress

## EXTENDED RUN-TIME FOR HIGH-OUTPUT UNITS

Product	Run time
ELM2 LED HO (no remotes)	3.9 hours

\* Meets Life Safety Code standard minimum illuminance of 0.1 FC and average illuminance of 1.0 FC. Assumes open space with no obstructions, mounting height: 7.5', ceiling height: 9', and reflectances: 80/50/20. Analysis based on independently tested photometrics.



ELM2\_LED