

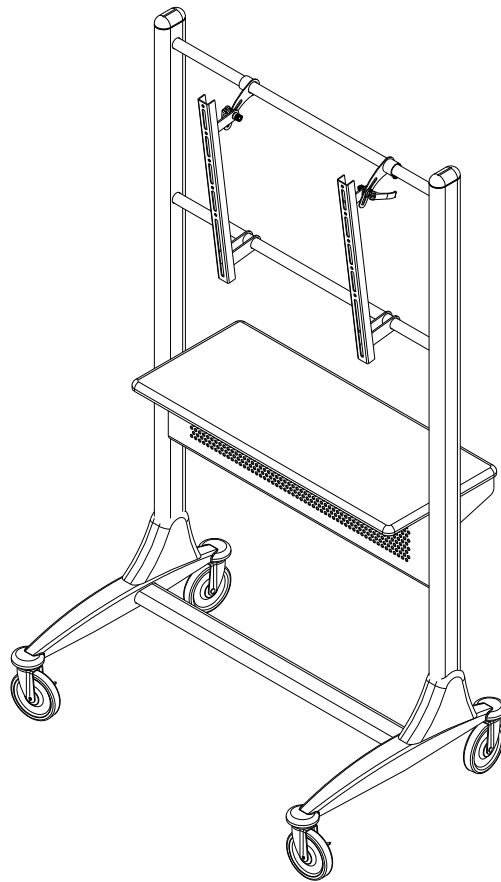









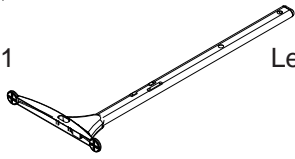

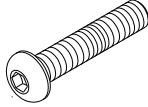



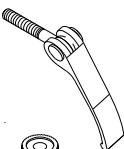

# #27544 Platinum Series Plasma/LCD Cart

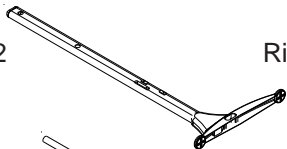

## Assembly Instructions

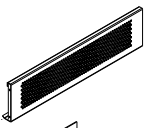
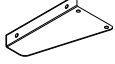
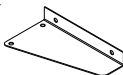
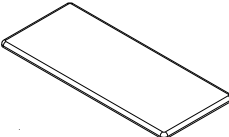
# #27544 Platinum LCD Cart

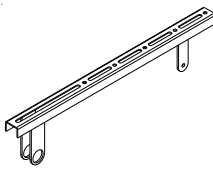
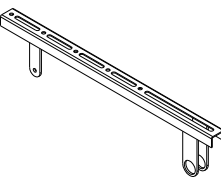
Part	Drawing	Description	Qty	Part	Drawing	Description	Qty
P1		Left Leg	1 EA	<b>Hardware List</b>  A  Screw M6X13mm 6 EA A1  Screw M8X40mm 4 EA A2  Screw M6X8mm 8 EA B  Plastic Washer 2 EA B1  Plastic Bushing 2 EA C  Clamp 2 EA D  Threaded Metal Cap 2 EA E  4" Locking Caster 2 EA F  4" Caster 2 EA G  Allen Wrench 1 EA H  Caster Wrench 1 EA			
P2		Right Leg	1 EA				
P3		LCD Tube	2 EA				
P4		Lower Cross Brace	1 EA				
P5		Stability Panel	1 EA				
P6		Left Shelf Bracket	1 EA				
P7		Right Shelf Bracket	1 EA				
P8		Wood Shelf	1 EA				
P9		Rotation Bracket-left	1 EA				
P10		Rotation Bracket-right	1 EA				
P11		Adj Bracket-left	1 EA				
P12		Adj Bracket-right	1 EA				

**NOTE:**

**Two people are required to assemble this unit.**

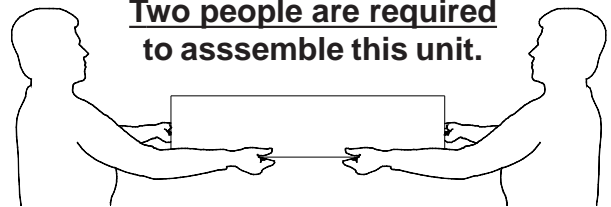

Do not use unless all screws are tight. At least every six months, check all screws to be sure they are tight. If parts are missing, broken, damaged, or worn, stop use of the product until repairs are made by your dealer using factory authorized parts.

# #27544 Platinum LCD Cart Assembly Diagram

**READ THROUGH INSTRUCTIONS FROM BEGINNING  
TO END BEFORE STARTING TO ASSEMBLE UNIT.**

**Illustration # 1**

- 1.) Identify and Separate all the Parts and Hardware.
- 2.) Slide Left and Right Rotation Bracket (P9 & P10) onto 1 LCD Tube (P3) as shown in illustration # 1.

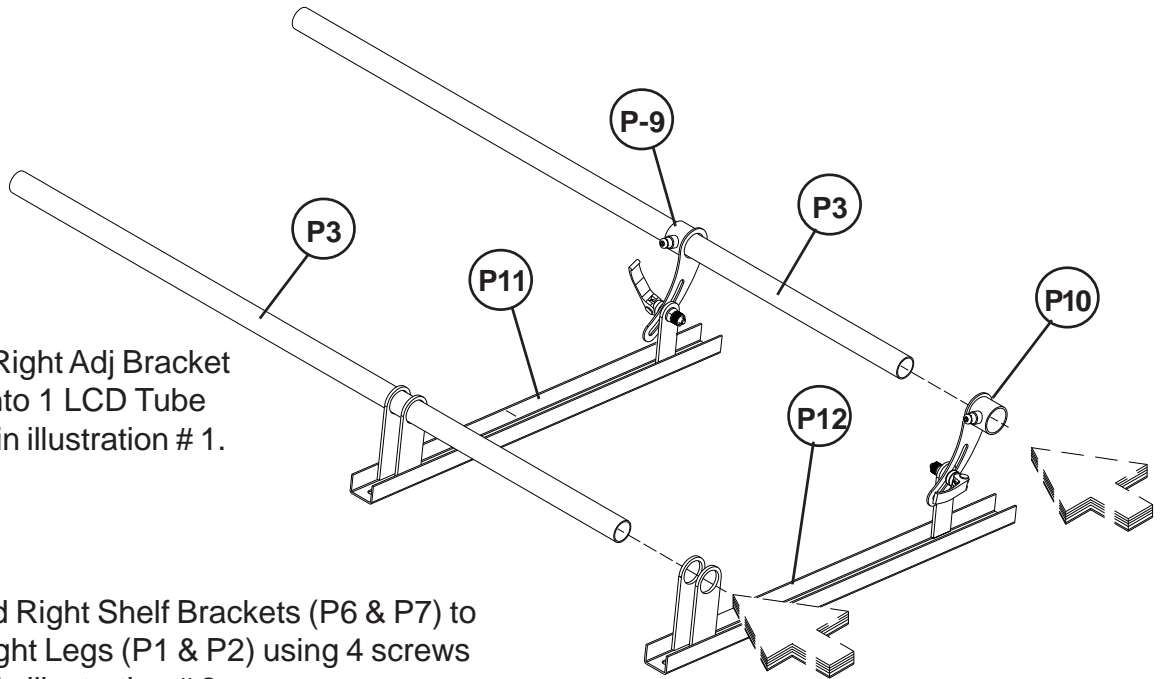

- 3.) Slide Left and Right Adj Bracket (P11 & P12) onto 1 LCD Tube (P3) as shown in illustration # 1.

- 4.) Attach Left and Right Shelf Brackets (P6 & P7) to the Left and Right Legs (P1 & P2) using 4 screws (A2) as shown in illustration # 2.

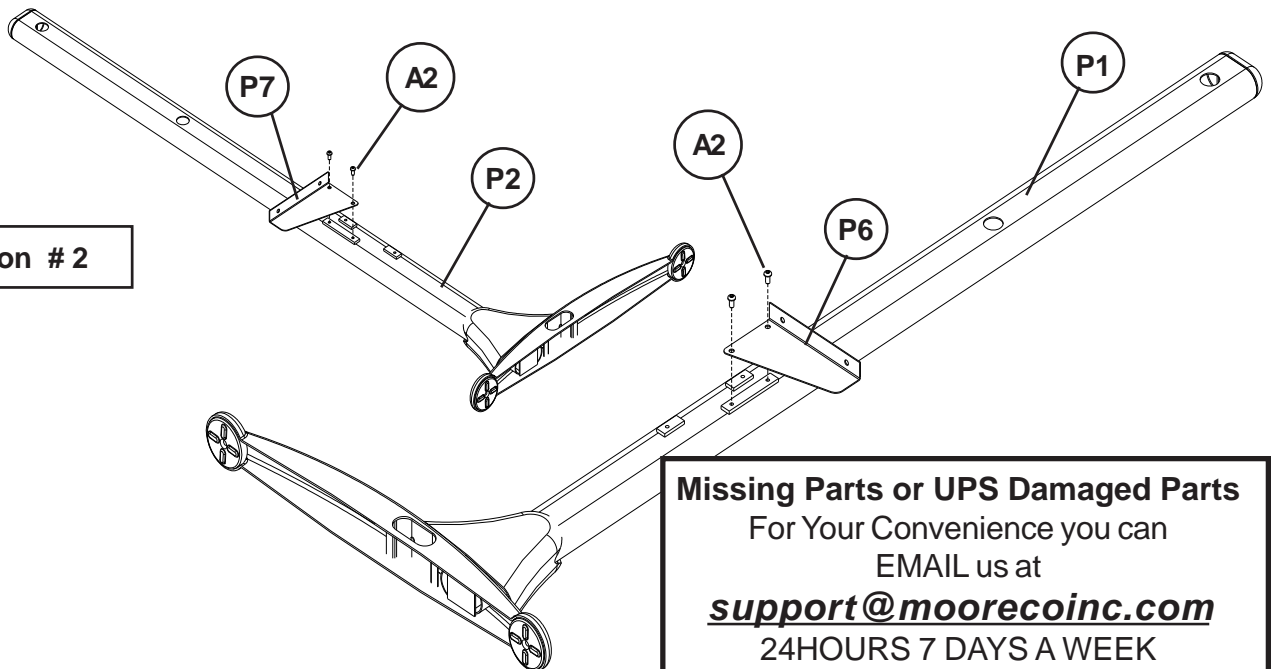

**Illustration # 2**

**Missing Parts or UPS Damaged Parts**  
For Your Convenience you can  
EMAIL us at  
***support@moorecoinc.com***  
24HOURS 7 DAYS A WEEK

5.) Insert 2 LCD Tubes (P3) into the Left and Right Legs (P1 & P2) as shown in illustration # 3.

6.) Attach Left and Right Legs (P1 & P2) to the Lower Cross Brace (P4) using 4 screws (A1) as shown in illustration # 3.

7.) Attach Stability Panel (P5) to the Left and Right Legs (P1 & P2) using 4 screws (A2) as shown in illustration # 3.

**Illustration # 3**

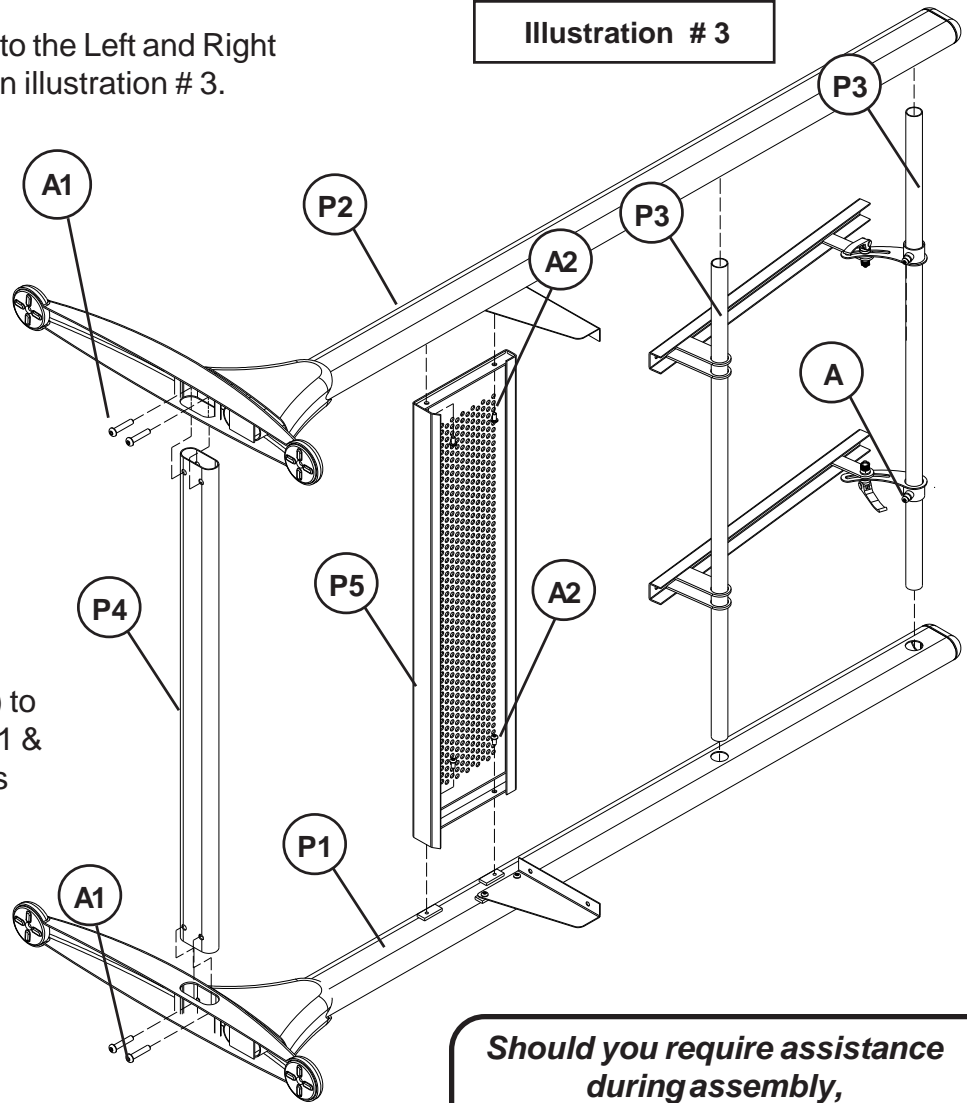

**Illustration # 4**

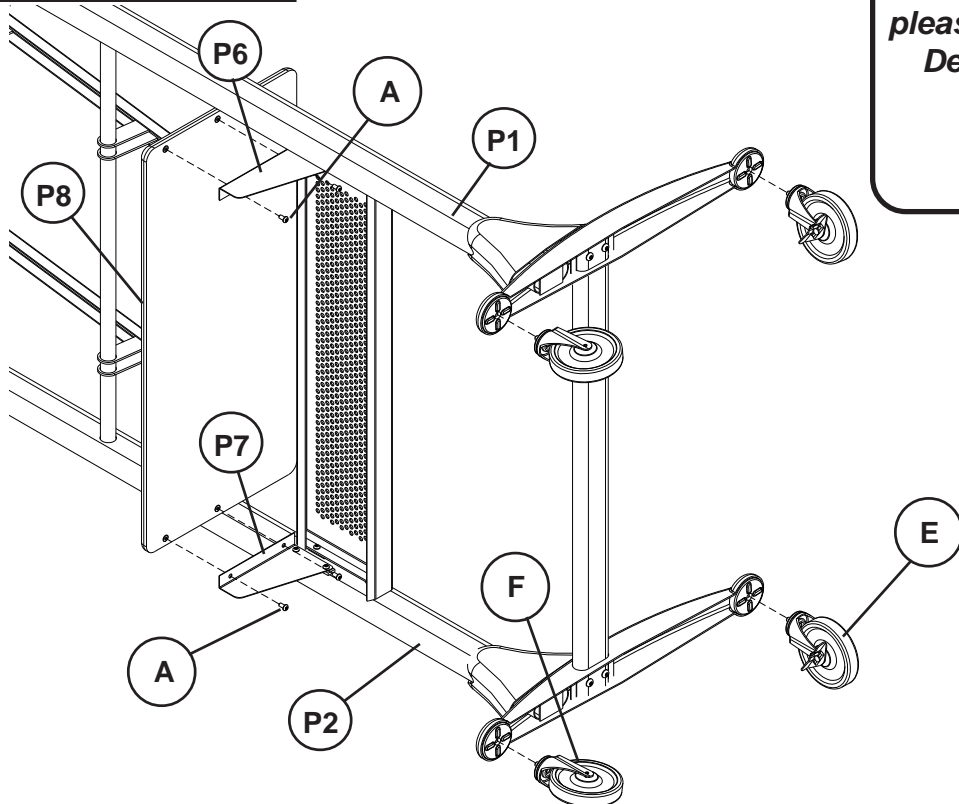

**Should you require assistance during assembly, please call our Customer Service Department Monday - Friday 8 a.m. - 5 p.m. Central Standard Time 1-800-749-2258**

8.) Attach Left and Right Shelf Brackets (P-6 & P-7) to Wood Shelf (P-8) using 4 screws (A) as shown in illustration # 4. Do not tighten.

9.) Attach 2 Locking Casters (E) and 2 Casters (F) to the bottom of the Left Leg (P1) & Right Leg(P2) as shown in illustration # 4. Tighten Casters using Caster Wrench (H).

Illustration # 5

10.) Secure Rotation Brackets (P9 & P10) using 2 Clamps (C), 2 Plastic Washers (B), 2 Plastic Bushings (B1), and 2 Threaded Metal Caps (D) as shown in illustration # 5.

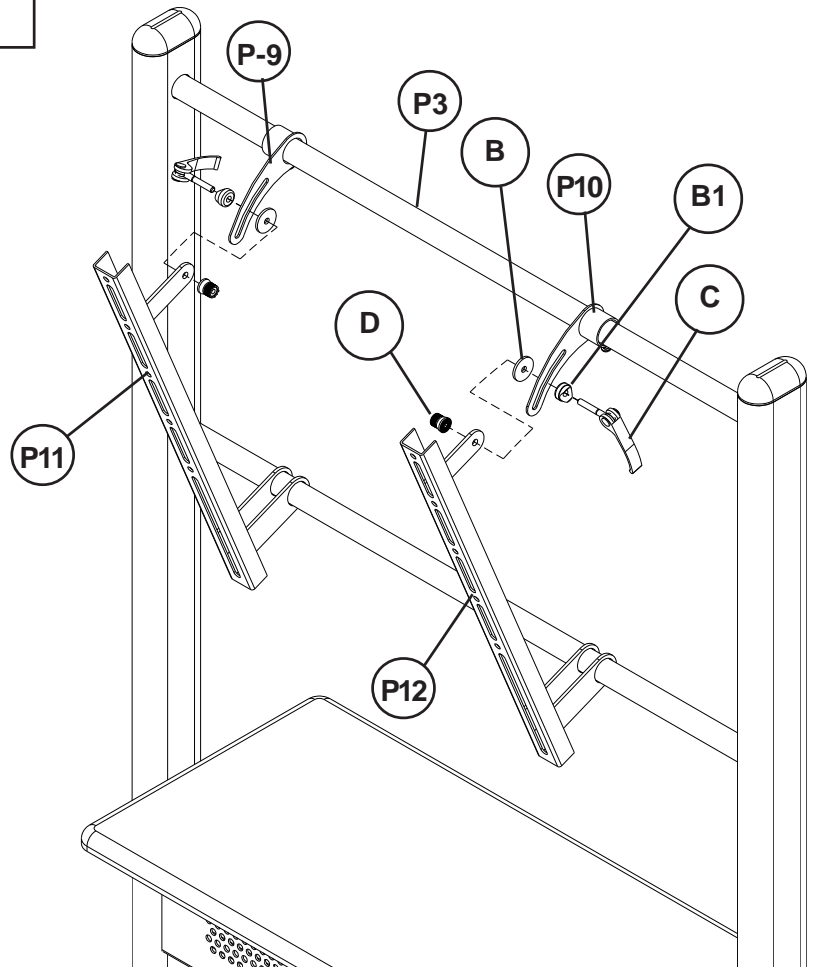
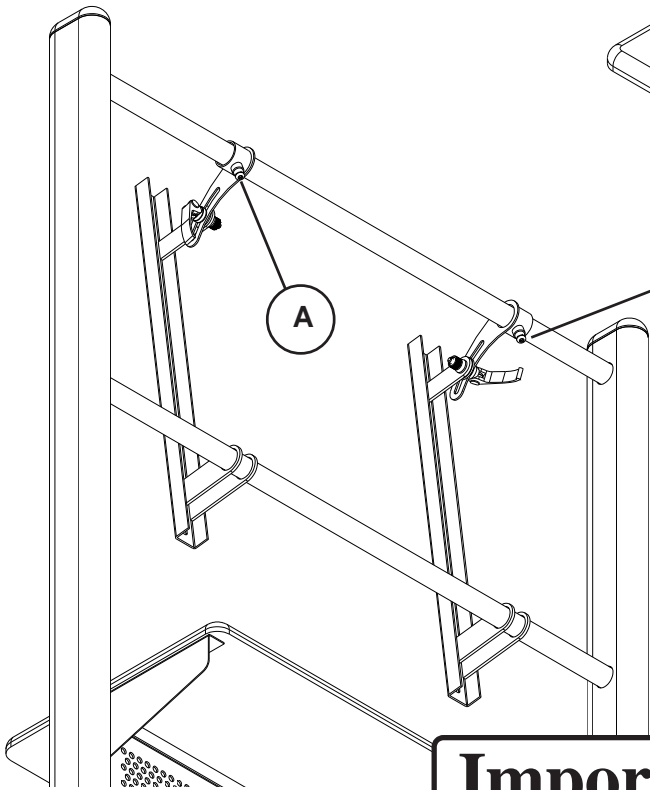

Illustration # 6



Secure Brackets at desired width by tightening (A) screws using Allen Wrench (G).

## Important

The Balt product you have purchased is guaranteed against material and workmanship defects. This guarantee extends 1 year from date of purchase. Should this product fail to function satisfactorily under normal use due to defect or imperfection, the defective part or product will be replaced. Damage caused by common carriers during shipment is not included in this guarantee.

**This guarantee sets forth all applicable guarantees and remedies. No other warranty, expressed or implied shall apply. Failure to follow instructions found in Important Information Section of Owner Sheet shall void the guarantee. Consequential or incidental damages and or costs are not refundable.**