

Series 11L Package

Security Lighting

50-150W HPS

PRODUCT OVERVIEW



Features:

- Die-cast aluminum head meets NEMA dimension standards
- For quick easy installation of mast arm, a cast-in external slipfitter is used for a secure mounting
- Includes 18" mast arm, lamp, photocontrol, pre-wire, and hardware
- All components in single carton
- Open bottom acrylic
- Suitable for -30°C MH / -40°C HPS
- Complies with ANSI: C136.2, C136.6, C136.10
- UL Listed for wet locations

Applications:

- Rural areas
- Area lighting
- Small businesses

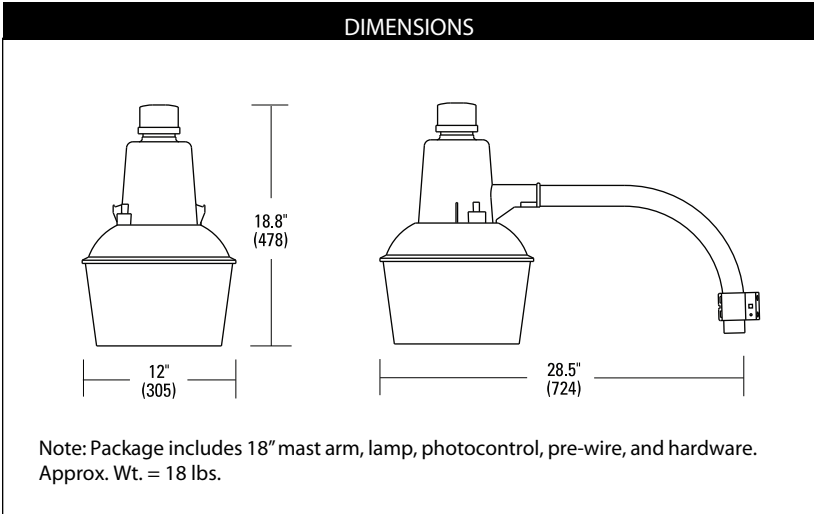

PREFERRED SELECTION CATALOG NUMBERS

11L 10S RN 120 R5 BA
11L 15S RN 120 R5 BA

Series 11L Package

Security Lighting

50-150W HPS

ORDERING INFORMATION

Example: 11L 15S XN 120 R5 BA

Series	Wattage / Source		Ballast	Voltage	Distribution	Optics
11L Security Package	05 50W	S HPS	RN Reactor Normal Power Factor	120 120V	R5 Type V	BA Open Bottom Acrylic
	07 70W		XN High Reactance / Lag Normal Power Factor	208 208V		
	10 100W			240 240V		
	15 150W			277 277V		
				MT1 120V Multi-tap		
				MT8 208 Multi-tap		
				MT2 240V Multi-tap		
				MT7 277V Multi-tap		

Package includes 18" mast arm, lamp, photo-control, pre-wire and hardware

Options

Photocontrol

(blank) Photocontrol included per voltage specified

Notes:

1 Available in 1-1/4" aluminum pipe only

Mast Arm

WA Welded Arm (24" mast arm) ¹

Listing

(blank) UL Listed (standard)
CS CSA Certified

BALLAST MATRIX

Nema Head 11L

Watts	120	208	240	277	MT1	MT2	MT7	MT8
05S	RN, XN	XN	XN	XN	XN	XN	XN	XN
07S	RN, XN	XN	XN	XN	XN	XN	XN	XN
10S	RN, XN	XN	XN	XN	XN	XN	XN	XN
15S	RN, XN	XN	XN	XN	XN	XN	XN	XN

