

Thank you for purchasing the IC-F1000 series VHF TRANSCEIVERS or IC-F2000 series UHF TRANSCEIVERS.
READ ALL INSTRUCTIONS carefully and completely before using the transceiver.

SUPPLIED ACCESSORIES

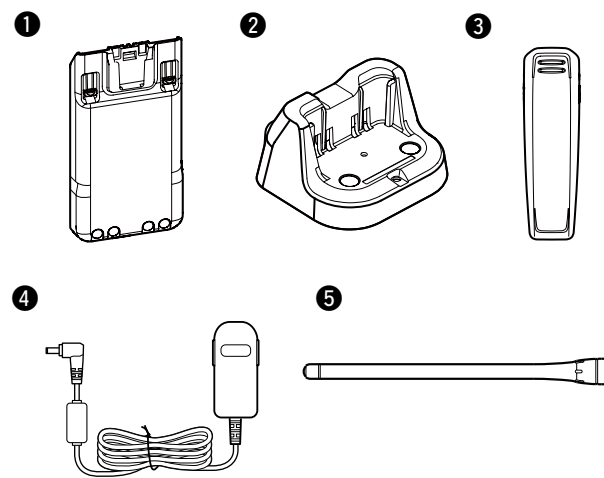

- 1 Battery pack (BP-279)
- 2 Battery charger (BC-213)
- 3 Belt clip (MB-133)
- 4 AC adapter* (for the battery charger)
- 5 Flexible antenna*

* Not supplied, or the shape is different, depending on the transceiver version.

PANEL DESCRIPTION

There are three types of transceivers in the IC-F1000 and IC-F2000 series.

- IC-F1000/F2000: Non-Display Type
- IC-F1000S/F2000S: Simple Type [LCD + 4 keys (P0-P3)]
- IC-F1000T/F2000T: 10-Key Type [LCD + 4 keys + 10-Key Pad]

◇ About the LED Indicator

- Lights red while transmitting.
- Lights green while receiving a signal, or when the squelch is open.
- Lights or blinks orange when the matched 2-Tone or 5-Tone is received, depending on the presetting.
- You should charge the battery when the indicator slowly blinks green.
- You must charge the battery when the indicator blinks green fast.

◇ About the Speaker microphone jack

CAUTION: Only when the jack cover or the optional HM-168LWP is attached, the transceiver meets IP67 requirements for dust-tight and waterproof protection.

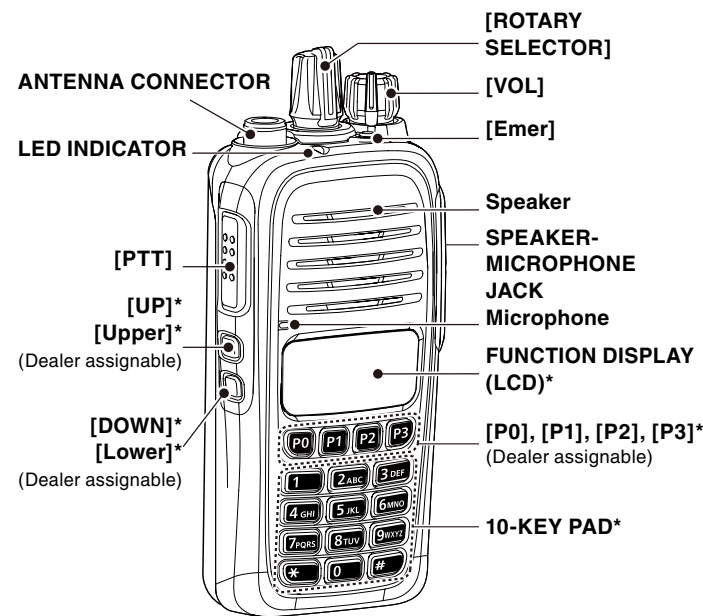

The illustration is for the 10-key type transceivers.

* Depending on the transceiver version

FUNCTION DISPLAY

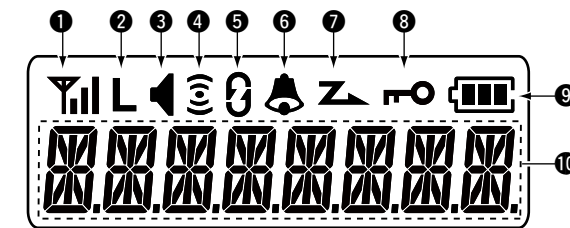

1 SIGNAL STRENGTH INDICATOR

Displays the relative receive signal strength level.

2 LOW POWER ICON

Appears when low output power is selected.

- When the battery charge decreases to a set level, low power is automatically selected.

3 AUDIBLE ICON

Appears when the channel is in the 'audible' (unmuted) mode.

- Appears when a matched 2-Tone or 5-Tone is received.

4 COMPANDER ICON

Appears when the Compander function is ON.

5 SCRAMBLER ICON

Appears when the Voice Scrambler function is ON.

6 BELL ICON

Appears or blinks when a matched 2-Tone or 5-Tone is received, depending on the presetting.

7 SCAN ICON

Appears or blinks while scanning.

8 KEY LOCK ICON

Appears when the Key Lock function is ON.

9 BATTERY INDICATOR

Displays the remaining battery charge. Blinks when the battery charge decreases to a set level.

10 ALPHANUMERIC READOUT

Displays messages such as channel text.

BATTERY CHARGING

◇ Rapid charging the supplied BC-213

The BC-213 DESKTOP CHARGER rapidly charges the Li-ion battery pack.

The BC-213 is used with an AC adapter or the CP-23L CIGARETTE LIGHTER CABLE (purchase separately).

• Charging time of the BP-279

Approximately 2 to 3 hours

CAUTION: STOP charging, if the charge indicator lights orange and green alternately.

NOTE: Charge the battery within the specified temperature range of +10°C to +40°C (+50°F to +104°F). Otherwise, the charging time will be longer, but the battery will not reach a full charge. While charging, at a point after the temperature goes out of the specified range, the charging will automatically stop.

◇ Rapid charging the BC-214

The BC-214 MULTI CHARGER (purchase separately) can simultaneously charge up to 6 Li-ion battery packs.

The BC-214 is used with BC-157S AC ADAPTER (purchase separately) or the OPC-656 DC POWER CABLE (purchase separately).

• Charging time of the BP-279

Approximately 2 to 3 hours

For more information about Icom accessories, please read the "OPTIONS" printed on the reverse side of this instruction sheet.

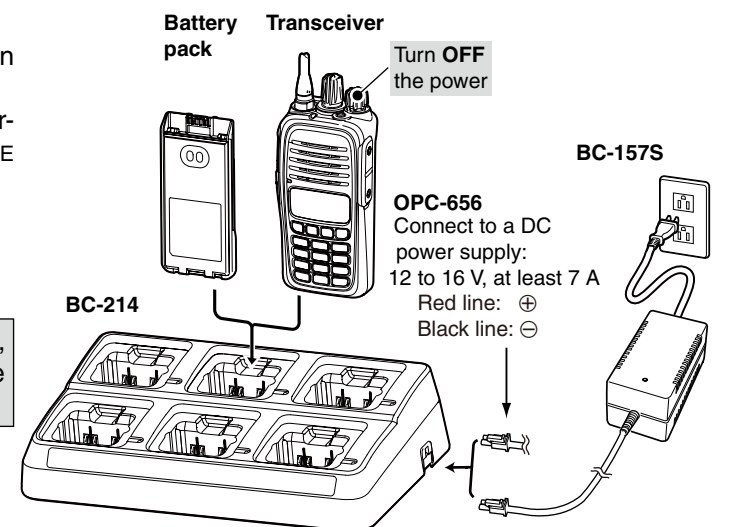
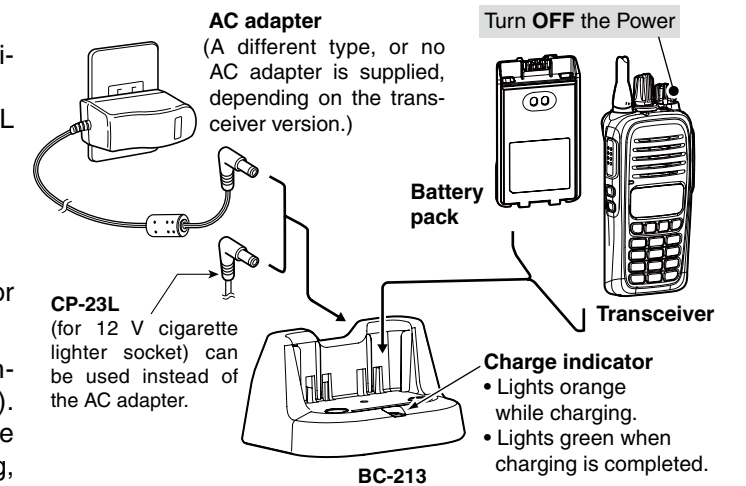

BASIC OPERATION

◇ Turning power ON

Before using the transceiver for the first time, the battery pack must be fully charged for optimum life and operation. See the instructions on page 2.

Rotate [VOL] to turn ON the power.

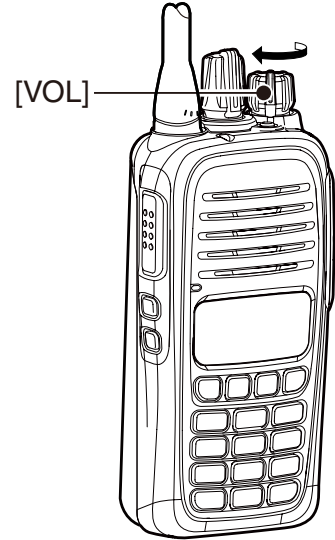

◇ Receiving and Transmitting

CAUTION:

Attach an antenna before transmitting. Transmitting without an antenna may damage the transceiver.

Receiving:

- ① Rotate [ROTARY SELECTOR], or push one of the memory channel keys, [MR-CH 1] to [MR-CH 4], to select a channel.
- ② When receiving a call, adjust the audio output level to a comfortable listening level.

Transmitting:

Wait until the channel is clear to avoid interference.

- ① While holding down [PTT], speak at a normal voice level.
- ② Release [PTT] to receive.

IMPORTANT:

- To maximize the readability of your signal:
1. After pushing [PTT], pause briefly before you start speaking.
 2. Hold the microphone 5 to 10 cm (2 to 4 inches) from your mouth, then speak at a normal voice level.

OPTIONS (Continued)

- **FA-SC25U/FA-SC57U/FA-SC72U/FA-SC73US** UHF ANTENNAS
 - FA-SC25U: 400–430 MHz
 - FA-SC57U: 430–470 MHz
 - FA-SC72U: 470–520 MHz
 - FA-SC73US: 450–490 MHz

- **FA-SC61UC** UHF CUT ANTENNA
 - FA-SC61UC: 380–520 MHz

◇ OTHERS

- **MB-130** MOBILE BRACKET
 - Mounts the BC-213 DESKTOP CHARGER on a variety of places in a vehicle.

- **MB-133** BELT CLIP

- **HM-158LA/HM-159LA/HM-168LWP** SPEAKER MICROPHONE
 - Combination speaker-microphone that provides convenient operation while the transceiver is hanging on your belt.

- **HM-153LA/HM-166LA** EARPHONE-MICROPHONE
 - Ideal for hands-free operation. Clip the HM-153LA or HM-166LA (with integrated PTT SWITCH) to your lapel or breast pocket.

- **HS-94/HS-95/HS-97** HEADSET
 - + **VS-4LA** PTT SWITCH CABLE
 - HS-94 : Ear-hook type
 - HS-95 : Neck-arm type
 - HS-97 : Throat microphone
 - VS-4LA: To connect to headsets

Some options may not be available in some countries. Ask your dealer for details.

Approved Icom optional equipment is designed for optimal performance when used with an Icom transceiver. Icom is not responsible for the destruction or damage to an Icom transceiver in the event the Icom transceiver is used with equipment that is not manufactured or approved by Icom.

OPTIONS

◇ BATTERY PACKS

- **BP-278/BP-279** BATTERY PACK

Battery pack	Voltage	Capacity	Battery life*	
BP-278	7.2 V	1130 mAh (minimum)	VHF	10 hours
		1190 mAh (typical)	UHF	10 hours
BP-279	7.2 V	1485 mAh (minimum)	VHF	14 hours
		1570 mAh (typical)	UHF	14 hours

* When the power save function is turned ON, and the operating periods are calculated under the following conditions.

TX : RX : standby = 5 : 5 : 90

◇ CHARGERS

- **BC-213** DESKTOP CHARGER + **BC-123S** AC ADAPTER
 - To rapid charge a single battery pack.
- **BC-214** MULTI CHARGER + **BC-157S** AC ADAPTER
 - To rapid charge up to 6 battery packs.

◇ DC CABLES

- **CP-23L** CIGARETTE LIGHTER CABLE
 - Use when charging the battery pack from a 12 V cigarette lighter socket. (Use with the BC-213)

- **OPC-656** DC POWER CABLE
 - Use with a 13.8 V power source instead of the AC adapter. (Use with the BC-214)

◇ ANTENNAS

- **FA-SC25V/FA-SC55V/FA-SC62V/FA-SC63V** VHF ANTENNAS
 - FA-SC25V: 136–150 MHz
 - FA-SC55V: 150–174 MHz
 - FA-SC62V: 150–160 MHz
 - FA-SC63V: 155–165 MHz

- **FA-SC56VS/FA-SC57VS** VHF STUBBY ANTENNAS
 - FA-SC56VS: 150–162 MHz
 - FA-SC57VS: 160–174 MHz

- **FA-SC61VC** VHF CUT ANTENNA
 - FA-SC61VC: 136–174 MHz

Icom, Icom Inc. and the Icom logo are registered trademarks of Icom Incorporated (Japan) in Japan, the United States, the United Kingdom, Germany, France, Spain, Russia and/or other countries. All other products or brands are registered trademarks or trademarks of their respective holders.