

Sentinel Mark II® Balance Pressure Diverter Valve and Trim

FEATURES:

- Sentinel Mark II concealed anti-scald balanced pressure valve with integral diverter and integral stops.
- Chrome plated brass wall plate with metal index.
- Chrome plated brass lever handle.
- Independent center sleeve allows up to 1 in. of rough-in variation.
- Adjustable temperature limit stop.
- Brass valve body.
- Pressure balancing & ceramic temperature regulating cartridge with built-in check valves.
- Can be installed back-to-back.
- Roughing-in template included.
- Vandal-resistant standard.
- Four port valve with ½ in. NPT Male (1/2 in. copper sweat) inlets and outlets.
- Furnished with ½ in. pipe cap.



STOCK FINISH:



PC

STANDARDS:

- ASME 112.18.1/CSA B125.1 certified
- ASSE 1016 certified

WARRANTY:

Visit www.speakman.com for full product warranty information

- 1 Year Limited Warranty (commercial)
- Limited Lifetime Warranty (residential)



Information continues on next page

NOTE: 1. All dimensions are in inches (millimeters) unless otherwise specified and are subject to change without notice. 2. Unless otherwise specified, all inlets and outlets are 1/2" female copper sweat. 3. For ADA mounting locations, consult ADAAG, ANSI A117.1, or static regulations

Architect/Engineer Approval Space:

P: 800-537-2107
F: 800-977-2747
W: WWW.SPEAKMAN.COM
R: 01-SEPTEMBER 2021

Sentinel Mark II® Balance Pressure Diverter Valve and Trim

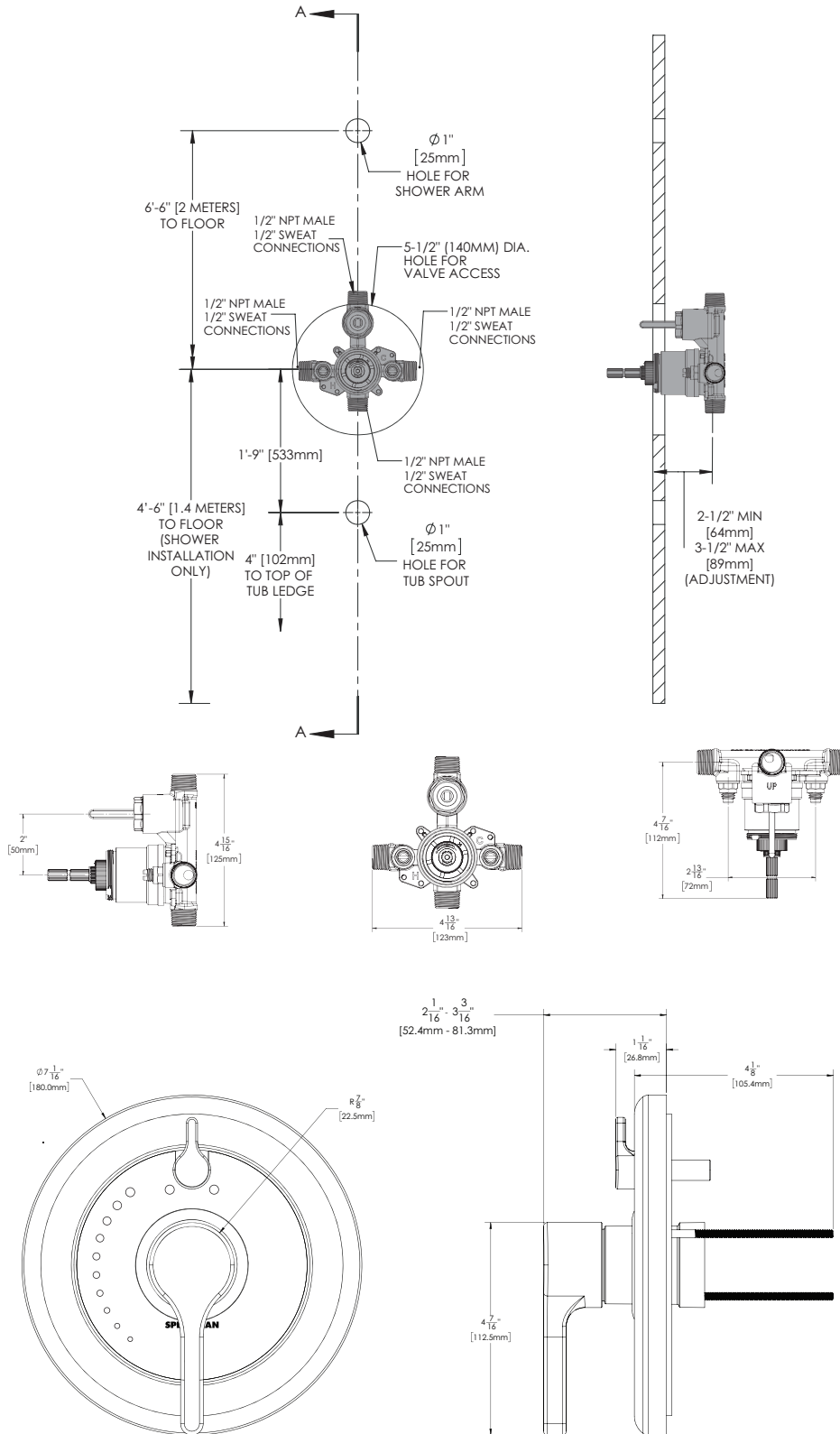

TRIM IS SHOWN AT A ROUGH-IN DEPTH OF 3.0in

NOTE: 1. All dimensions are in inches (millimeters) unless otherwise specified and are subject to change without notice. 2. Unless otherwise specified, all inlets and outlets are 1/2" female copper sweat. 3. For ADA mounting locations, consult ADAAG, ANSI A117.1, or static regulations

Architect/Engineer Approval Space:

P: 800-537-2107
 F: 800-977-2747
 W: WWW.SPEAKMAN.COM
 R: 01-SEPTEMBER 2021