

## Wall-Mounted Rectangular Eyewash Bowl

### FEATURES:

- (2) aerated yellow plastic spray outlets
- Rectangular stainless steel bowl
- Stainless steel push trigger bar activation
- Chrome plated 1/2" NPT female brass valve
- 1/2" NPT female inlet
- Chrome plated brass in-line strainer
- 2.8 GPM (10.6 L/min) @ 30 PSI flow rate
- Cold-rolled steel, DuraJade™ powder coated mounting bracket for durability & enhanced corrosion resistance
- Universal emergency sign included

### OPTIONS:

- FPV: Freeze Protection Valve
- HFO: Hand/Foot Operation
- HS: Hand held drench hose
- ILS: In-line strainer for 1/2" IPS piping
- PT: P-Trap
- SPV: Scald Protection Valve
- SSBV2: 1/2" Stainless Steel Ball Valve

### ADD-ONS:

- SE-TW-EW: Thermostatic Mixing Valve

### STANDARDS:

- ANSI/ISEA Z358.1 certified

### WARRANTY:

Visit [www.speakman.com](http://www.speakman.com) for full product warranty information

- 3 Year Limited Warranty (commercial)



Information continues on next page

**ENSURE YOU ARE ANSI/ISEA Z358.1  
Tepid Water Compliant**  
by incorporating Speakman's 9.7 GPM  
Thermostatic Mixing Valve.



- **STW-370:** Thermostatic Mixing Valve (valve only)
- **SE-TW-EW:** Thermostatic Mixing Valve with necessary connections for eye and eye/face wash products

All dimensions are in inches (millimeters) unless otherwise specified and are subject to change without notice.

Architect/Engineer Approval Space:

P: 800-537-2107  
F: 800-977-2747  
W: [WWW.SPEAKMAN.COM](http://WWW.SPEAKMAN.COM)  
R: 02-NOVEMBER 2019

## Wall-Mounted Rectangular Eyewash Bowl

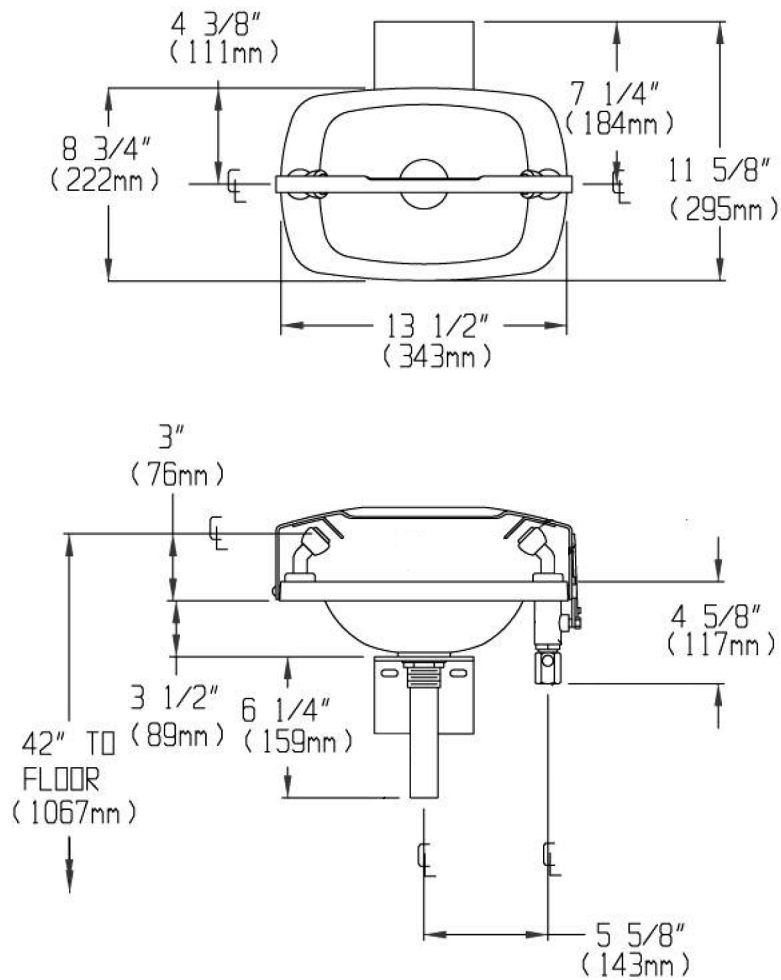

All dimensions are in inches (millimeters) unless otherwise specified and are subject to change without notice.

Architect/Engineer Approval Space:

P: 800-537-2107  
F: 800-977-2747  
W: WWW.SPEAKMAN.COM  
R: 02-NOVEMBER 2019