



NHA8738803

Altivar - Lexium

Braking resistors: VW3A7730...757

	Ω	kW 50°C (122°F)		Ω	kW 50°C (122°F)		Ω	kW 50°C (122°F)
VW3A7730	100	0.1	VW3A7740	100	0.26	VW3A7750	100	1.4
VW3A7731	60	0.16	VW3A7741	60	0.5	VW3A7751	60	2.9
VW3A7732	28	0.3	VW3A7742	28	0.96	VW3A7752	28	5.1
VW3A7733	16	0.96	VW3A7743	16	1.9	VW3A7753	16	14
VW3A7734	10	0.96	VW3A7744	10	2.9	VW3A7754	10	19
VW3A7735	8	0.96	VW3A7745	8	3.8	VW3A7755	8	25
VW3A7736	5	1.9	VW3A7746	5	6.9	VW3A7756	5	32
VW3A7737	2.5	3.2	VW3A7747	2.5	11	-	-	-
VW3A7738	1.4	1.5	VW3A7748	1.4	5.1	VW3A7757	1.4	29

⚠ ⚠ DANGER

HAZARD OF ELECTRIC SHOCK, EXPLOSION, OR ARC FLASH

- Only appropriately trained persons who are familiar with and understand the contents of this manual and all other pertinent product documentation and who have received safety training to recognize and avoid hazards involved are authorized to work on and with this drive system. Installation, adjustment, repair, and maintenance must be performed by qualified personnel.
 - The system integrator is responsible for compliance with all local and national electrical code requirements as well as all other applicable regulations with respect to grounding of all equipment.
 - Many components of the product, including the printed circuit boards, operate with mains voltage. Do not touch. Use only electrically insulated tools.
 - Do not touch unshielded components or terminals with voltage present.
 - Motors can generate voltage when the shaft is rotated. Prior to performing any type of work on the drive system, block the motor shaft to prevent rotation.
 - AC voltage can couple voltage to unused conductors in the motor cable. Insulate both ends of unused conductors of the motor cable.
 - Do not short across the DC bus terminals or the DC bus capacitors or the braking resistor terminals.
 - Before performing work on the drive system:
 - Disconnect all power, including external control power that may be present.
 - Place a "Do Not Turn On" label on all power switches.
 - Lock all power switches in the open position.
 - Wait 15 minutes to allow the DC bus capacitors to discharge. The DC bus LED is not an indicator of the absence of DC bus voltage that can exceed 800 Vdc.
 - Measure the voltage on the DC bus between the DC bus terminals (PA/+ and PC/-) using a properly rated voltmeter to verify that the voltage is <42 Vdc.
 - If the DC bus capacitors do not discharge properly, contact your local Schneider Electric representative. Do not repair or operate the product.
 - Install and close all covers before applying voltage.
- Failure to follow these instructions will result in death or serious injury.**

Electrical equipment should be installed, operated, serviced, and maintained only by qualified personnel. No responsibility is assumed by Schneider Electric for any consequences arising out of the use of this product.

© 2021 Schneider Electric. All Rights Reserved.

DANGER

RISK OF FIRE

Before installing the product, verify that all cardboard and other packaging material has been completely removed from the product.

Failure to follow these instructions will result in death or serious injury.

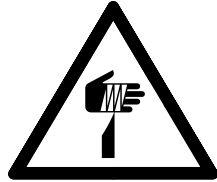

CAUTION

SHARP EDGES

- Use all necessary personal protective equipment (PPE) such as gloves when performing any type of work whatsoever on or with the braking resistor.
- Ensure that no other persons can perform any type of work whatsoever on or with the braking resistor unless such persons use all necessary personal protective equipment (PPE) such as gloves.
- The cut resistance of the gloves must be at least level C as per ISO 23388 or level A2 as per ANSI/ISEA 105.

Failure to follow these instructions can result in injury or equipment damage



The metal surfaces of the product may reach 150°C (302°F) during operation.

WARNING

HOT SURFACES

- Ensure that any contact with hot surfaces is avoided.
- Do not allow flammable or heat-sensitive parts in the immediate vicinity of hot surfaces.
- Verify that the heat dissipation is sufficient by performing a test run under maximum load conditions.

Failure to follow these instructions can result in death, serious injury, or equipment damage.



brP-



www.schneider-electric.com

	A	B	C	A1	C1	Ø
	mm (in.)	mm (in.)	mm (in.)	mm (in.)	mm (in.)	mm (in.)
VW3A7730	105 (4.13)	100 (3.94)	295 (11.61)	72 (2.83)	266 (10.47)	4.5 (0.18)
VW3A7731	105 (4.13)	100 (3.94)	345 (13.58)	72 (2.83)	316 (12.44)	4.5 (0.18)
VW3A7732	175 (6.89)	100 (3.94)	345 (13.58)	142 (5.59)	316 (12.44)	4.5 (0.18)
VW3A7740	105 (4.13)	100 (3.94)	465 (18.31)	72 (2.83)	436 (17.16)	4.5 (0.18)
VW3A7741	175 (6.89)	100 (3.94)	465 (18.31)	142 (5.59)	436 (17.16)	4.5 (0.18)

	A	B	C	A1	C1	Ø
	mm (in.)	mm (in.)	mm (in.)	mm (in.)	mm (in.)	mm (in.)
VW3A7733	190 (7.48)	180 (7.09)	570 (22.44)	170 (6.69)	380 (14.96)	6.6 x 9 (0.26 x 0.35)
VW3A7734	190 (7.48)	180 (7.09)	640 (25.20)	170 (6.69)	380 (14.96)	6.6 x 9 (0.26 x 0.35)
VW3A7735	190 (7.48)	180 (7.09)	640 (25.20)	170 (6.69)	380 (14.96)	6.6 x 9 (0.26 x 0.35)
VW3A7742	190 (7.48)	180 (7.09)	570 (22.44)	170 (6.69)	380 (14.96)	6.6 x 9 (0.26 x 0.35)
VW3A7743	290 (11.42)	180 (7.09)	570 (22.44)	270 (10.63)	380 (14.96)	6.6 x 9 (0.26 x 0.35)
VW3A7744	390 (15.35)	180 (7.09)	640 (25.20)	370 (14.57)	380 (14.96)	6.6 x 9 (0.26 x 0.35)
VW3A7750	290 (11.42)	180 (7.09)	570 (22.44)	270 (10.63)	380 (14.96)	6.6 x 9 (0.26 x 0.35)
VW3A7751	390 (15.35)	180 (7.09)	570 (22.44)	370 (14.57)	380 (14.96)	6.6 x 9 (0.26 x 0.35)

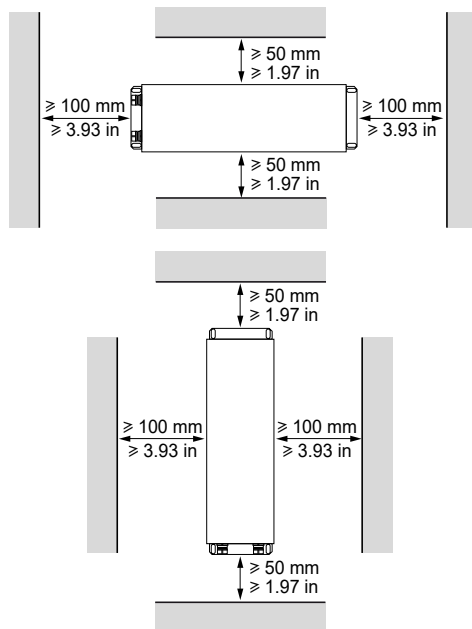
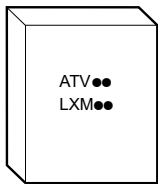
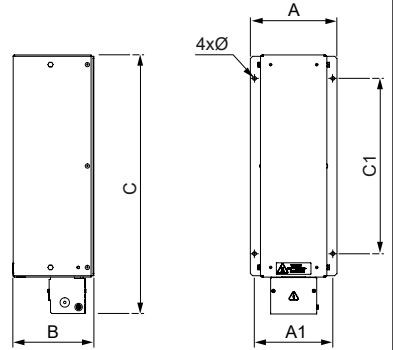
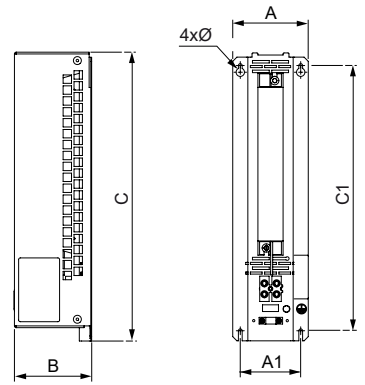

	A	B	C	A1	C1	A2	C2	Ø	kg
	mm (in.)	mm (in.)	mm (in.)	mm (in.)	mm (in.)	mm (in.)	mm (in.)	mm (in.)	(lb)
VW3A7736	330 (12.99)	485 (19.09)	485 (19.09)	310 (12.20)	380 (14.96)	450 (17.71)	540 (21.26)	9 x 12 (0.35 x 0.47)	18 (39.68)
VW3A7737	330 (12.99)	485 (19.09)	485 (19.09)	310 (12.20)	380 (14.96)	450 (17.71)	540 (21.26)	9 x 12 (0.35 x 0.47)	21 (46.30)
VW3A7738	330 (12.99)	445 (17.52)	485 (19.09)	310 (12.20)	380 (14.96)	450 (17.71)	540 (21.26)	9 x 12 (0.35 x 0.47)	17 (37.48)
VW3A7745	530 (20.87)	485 (19.09)	485 (19.09)	510 (20.08)	380 (14.96)	650 (25.59)	540 (21.26)	9 x 12 (0.35 x 0.47)	25.5 (56.22)
VW3A7746	530 (20.87)	485 (19.09)	485 (19.09)	510 (20.08)	380 (14.96)	650 (25.59)	540 (21.26)	9 x 12 (0.35 x 0.47)	30.5 (67.24)
VW3A7747	940 (37.00)	485 (19.09)	485 (19.09)	920 (36.22)	380 (14.96)	1060 (41.73)	540 (21.26)	9 x 12 (0.35 x 0.47)	48.5 (106.92)
VW3A7748	530 (20.87)	485 (19.09)	485 (19.09)	510 (20.08)	380 (14.96)	650 (25.59)	540 (21.26)	9 x 12 (0.35 x 0.47)	29 (63.93)
VW3A7752	530 (20.87)	485 (19.09)	485 (19.09)	510 (20.08)	380 (14.96)	650 (25.59)	540 (21.26)	9 x 12 (0.35 x 0.47)	27 (59.52)
VW3A7753	940 (37.00)	605 (23.82)	485 (19.09)	920 (36.22)	380 (14.96)	1060 (41.73)	540 (21.26)	9 x 12 (0.35 x 0.47)	48.5 (106.92)
VW3A7754	740 (29.13)	1035 (40.75)	485 (19.09)	720 (28.35)	380 (14.96)	860 (33.86)	540 (21.26)	9 x 12 (0.35 x 0.47)	71 (156.53)
VW3A7755	940 (37.00)	1035 (40.75)	485 (19.09)	920 (36.22)	380 (14.96)	1060 (41.73)	540 (21.26)	9 x 12 (0.35 x 0.47)	87.5 (192.90)
VW3A7756	940 (37.00)	1285 (50.59)	485 (19.09)	920 (36.22)	380 (14.96)	1060 (41.73)	540 (21.26)	9 x 12 (0.35 x 0.47)	126 (277.78)
VW3A7757	940 (37.00)	1285 (50.59)	485 (19.09)	920 (36.22)	380 (14.96)	1060 (41.73)	540 (21.26)	9 x 12 (0.35 x 0.47)	121 (266.76)

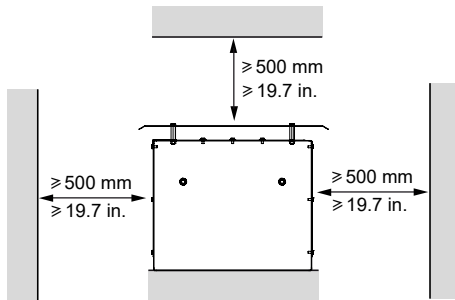
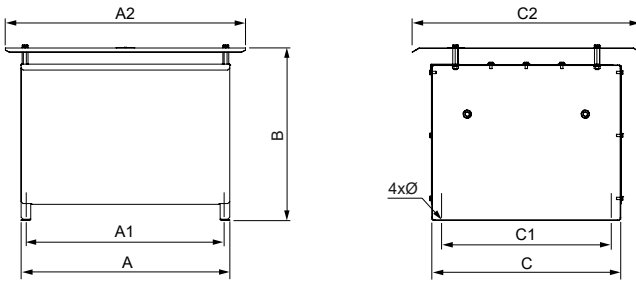

VW3A77●● ≥ 31 kg
68.34 lb

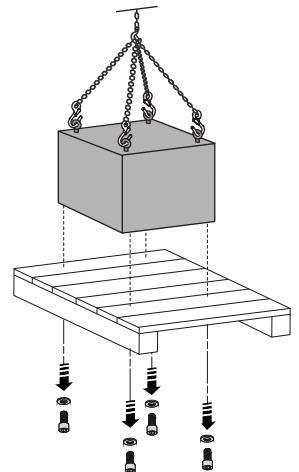

VW3A7730...732
VW3A7740, 741

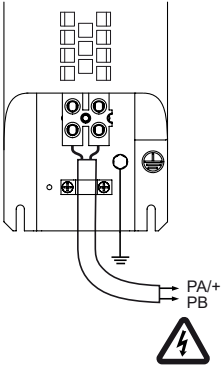

	Max.			
	PA+ PB		T1 T2	
	mm ² (AWG)	N.m (lbf.in)	mm ² (AWG)	N.m (lbf.in)
VW3A7730...732, VW3A7740, 741	10 (8)	1.35 (11.9)	-	-
VW3A7733, VW3A7742, 743, VW3A7750, 751	10 (8)	1.35 (11.9)	2.5 (12)	0.57 (5.0)
VW3A7734, 735, VW3A7744	35 (3)	4 (35.4)	4 (10)	0.5 (4.4)
VW3A7752...753	M6	5.7 (50.4)	2.5 (12)	0.51 (4.5)
VW3A7745	M8	8 (70.8)	2.5 (12)	0.51 (4.5)
VW3A7736, VW3A7746	M10	11 (97.3)	2.5 (12)	0.51 (4.5)
VW3A7737, 738, VW3A7747, 748, VW3A7754...757	M12	15.5 (137.1)	2.5 (12)	0.51 (4.5)

VW3A7733...735
VW3A7742...744
VW3A7750...751

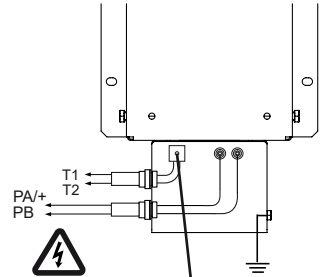

VW3A7736...738
VW3A7745...748
VW3A7752...757

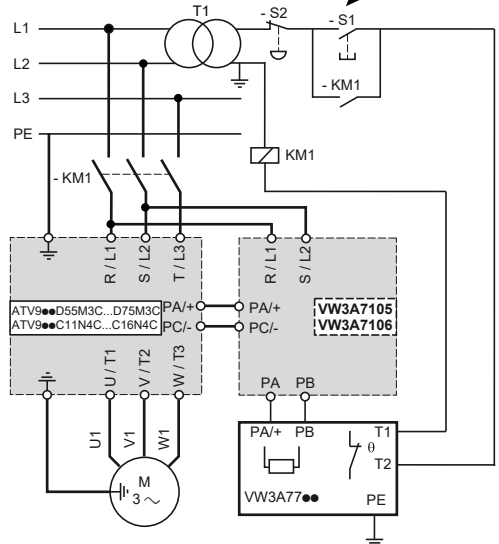
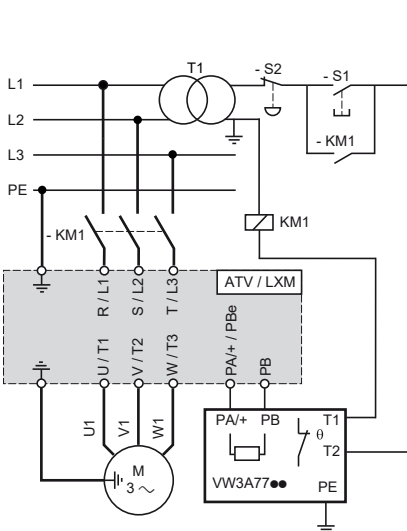
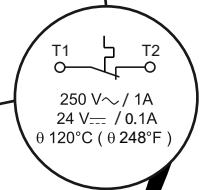
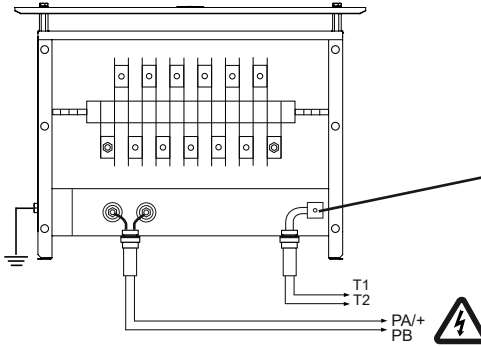

2x VW3A7754
2x VW3A7756

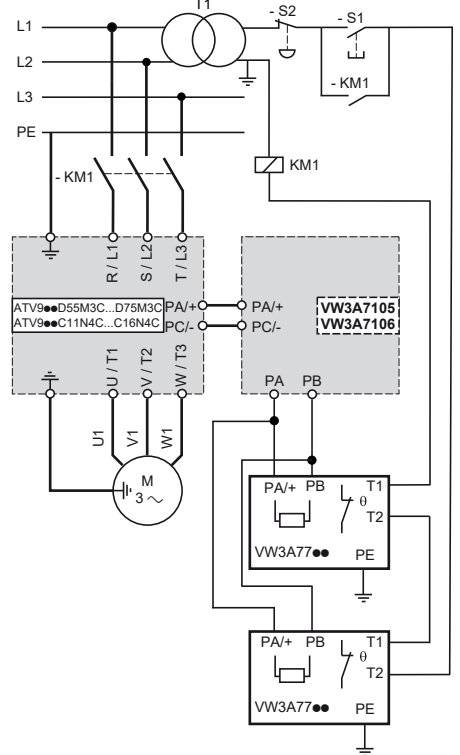
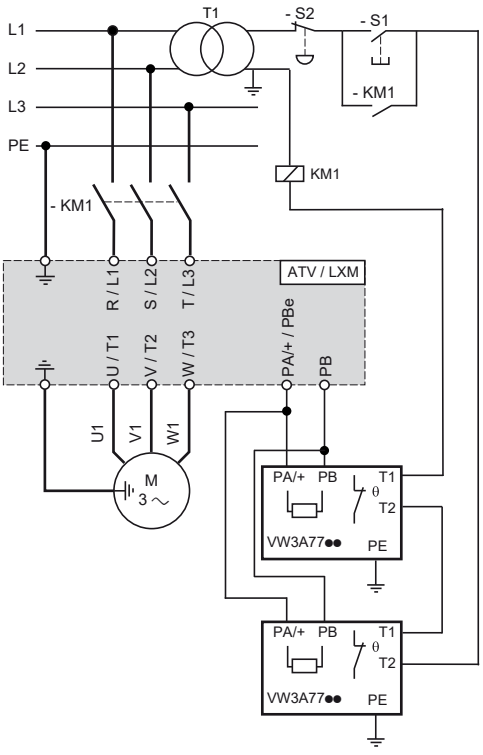
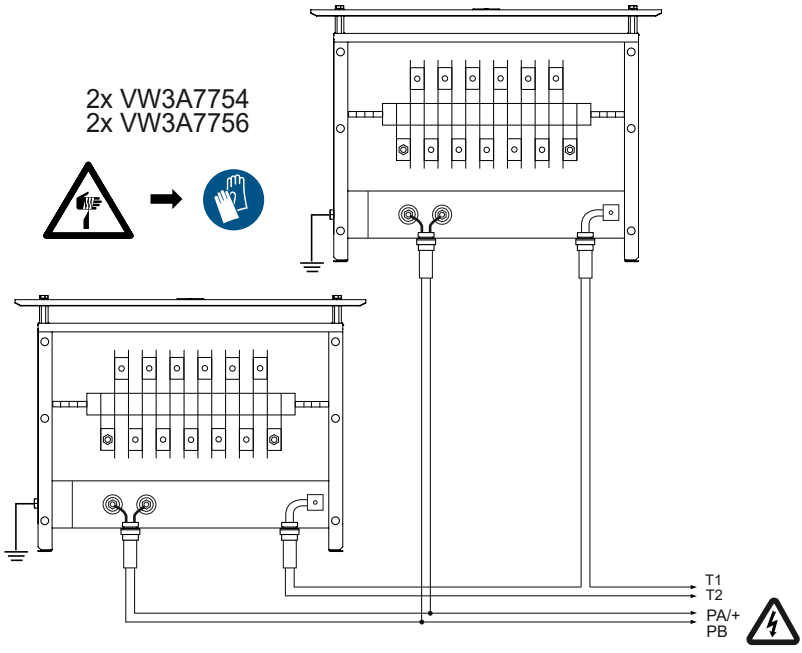
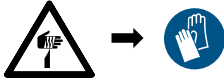

3x VW3A7754
3x VW3A7756

