



## Main

Range of product	Harmony XAP
Product or component type	Front plate with fixing screws
Device short name	XAPE
Product destination	For Ø 22 mm control and signalling units
Product front plate size	72 x 72 mm
Number of cut-out	1 cut-out
Material	Anodised aluminium
Device mounting	Flush
IP degree of protection	IP65 IEC 60529 IP657 NF C 20-010
Resistance to chemical agents	Good resistant to acetone Good resistant to alcohols Good resistant to chloride and fluoride solvents Good resistant to diluted mineral acids Good resistant to oils and petrol Good resistant to organic acids Good resistant to salts

## Complementary

Net Weight	0.11 lb(US) (0.05 kg)
------------	-----------------------

## Environment

Protective treatment	TH TC
Ambient air temperature for storage	-40...158 °F (-40...70 °C)
Ambient air temperature for operation	-13...158 °F (-25...70 °C)
Overvoltage category	Class I IEC 60536 Class I NF C 20-030

## Ordering and shipping details

Category	22475 - WALL STATIONS
Discount Schedule	CS2
GTIN	00785901315889
Nbr. of units in pkg.	1
Package weight(Lbs)	0.16 lb(US) (0.07 kg)
Returnability	Yes
Country of origin	FR

## Packing Units

Unit Type of Package 1	PCE
Package 1 Height	1.06 in (2.7 cm)
Package 1 width	5.08 in (12.9 cm)
Package 1 Length	6.14 in (15.6 cm)
Unit Type of Package 2	BAG
Number of Units in Package 2	1
Package 2 Weight	2.26 oz (64 g)
Package 2 Height	1.06 in (2.7 cm)

Package 2 width	5.08 in (12.9 cm)
Package 2 Length	6.14 in (15.6 cm)
Unit Type of Package 3	S02
Number of Units in Package 3	30
Package 3 Weight	5.31 lb(US) (2.408 kg)
Package 3 Height	5.91 in (15 cm)
Package 3 width	11.81 in (30 cm)
Package 3 Length	15.75 in (40 cm)

### Offer Sustainability

Sustainable offer status	Green Premium product
California proposition 65	WARNING: This product can expose you to chemicals including: Di-isodecyl phthalate (DIDP), which is known to the State of California to cause birth defects or other reproductive harm. For more information go to <a href="http://www.P65Warnings.ca.gov">www.P65Warnings.ca.gov</a>
REACH free of SVHC	Yes
EU RoHS Directive	Pro-active compliance (Product out of EU RoHS legal scope) <a href="#">EU RoHS Declaration</a>
Toxic heavy metal free	Yes
Mercury free	Yes
RoHS exemption information	<a href="#">Yes</a>
China RoHS Regulation	<a href="#">China RoHS Declaration</a>
Environmental Disclosure	<a href="#">Product Environmental Profile</a>
Circularity Profile	<a href="#">End Of Life Information</a>

### Contractual warranty

Warranty	18 months
----------	-----------

Dimensions and Fixing

Below drawing shows a front plate with 4 cut-outs. Refer to the product characteristics to get the number of cut-outs.

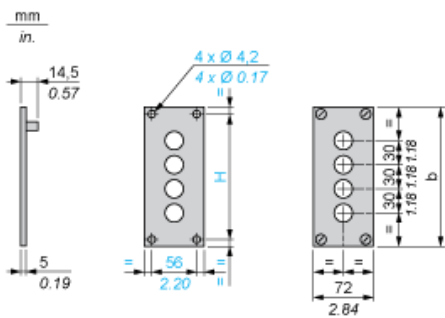

Panel cut-out

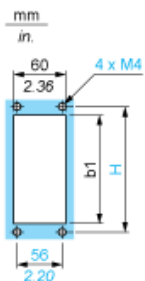

b		b1		H	
mm	in.	mm	in.	mm	in.
72	2.83	44	1.73	56	2.20