

Modicon X80

Discrete Input/Output Modules

User Manual

Original instructions

11/2020

35012474.18

Legal Information

The Schneider Electric brand and any trademarks of Schneider Electric SE and its subsidiaries referred to in this guide are the property of Schneider Electric SE or its subsidiaries. All other brands may be trademarks of their respective owners.

This guide and its content are protected under applicable copyright laws and furnished for informational use only. No part of this guide may be reproduced or transmitted in any form or by any means (electronic, mechanical, photocopying, recording, or otherwise), for any purpose, without the prior written permission of Schneider Electric.

Schneider Electric does not grant any right or license for commercial use of the guide or its content, except for a non-exclusive and personal license to consult it on an "as is" basis. Schneider Electric products and equipment should be installed, operated, serviced, and maintained only by qualified personnel.

As standards, specifications, and designs change from time to time, information contained in this guide may be subject to change without notice.

To the extent permitted by applicable law, no responsibility or liability is assumed by Schneider Electric and its subsidiaries for any errors or omissions in the informational content of this material or consequences arising out of or resulting from the use of the information contained herein.

Table of Contents

Safety Information	11
Before You Begin.....	12
Start-up and Test.....	13
Operation and Adjustments	14
About the Book	15
Hardware Installation of the Discrete I/O Modules	17
General Introduction.....	18
General Description of the Modules	18
Physical Description of Discrete Modules with 20-pin Terminal Block Connection	19
Physical Description of Discrete Modules with 40-pin Terminal Block Connection	21
Physical Description of Discrete Modules with 40-Pin Connectors	22
Discrete Input Modules Catalog	23
Discrete Output Modules Catalog	26
Discrete Mixed Input/Output Modules Catalog	29
Dimensions of X80 Discrete I/O Modules.....	31
Temperature Derating	34
Standards and Certifications.....	36
General Rules for Installing the Modules	37
Fitting of the Modules.....	37
20-pin Terminal Blocks: BMX FTB 20•0	40
40-pin Terminal Blocks: BMX FTB 40•0	43
BMX FTW ••1 Cable	49
BMX FTW ••5 Cable	53
Fitting a 20-pin Terminal Block to a Module.....	57
Fitting a 40-Pin Terminal Block to a Module.....	62
Fitting a 40-pin FCN Type Connector to a Module	67
Presentation for Choosing Power Supplies for Sensors and Pre-Actuators.....	68
Wiring Precautions	72
How to Connect Discrete Input/Output Modules: Connecting 40-Pin Connector Modules.....	76

- How to Connect Discrete Input/Output Modules: Connecting 40-Pin Connector Modules to TELEFAST Interfaces 82
- Sensor/Input Compatibility and Pre-actuator/Output Compatibility 87
- Discrete Input/Output Module Diagnostic Processing 91
 - General Protective Measures 91
 - Module and Channel Status Display..... 92
 - Diagnostics 96
 - Checking the Connection 99
- BMX DDI 1602 Input Modules 102
 - Introduction 102
 - Characteristics 103
 - Connecting the Module 105
- BMX DDI 1603 Input Modules 109
 - Introduction 109
 - Characteristics 110
 - Connecting the Module 112
- BMX DDI 1604T Input Modules 116
 - Introduction 116
 - Characteristics 117
 - Connecting the Module 120
- BMX DDI 3203 Input Modules 124
 - Introduction 124
 - Characteristics 125
 - Connecting the Module 127
- BMX DDI 3232 Input Modules 131
 - Introduction 131
 - Characteristics 132
 - Connecting the Module 134
- BMX DAI 1602 Input Modules 139
 - Introduction 139
 - Characteristics 140
 - Connecting the Module 142
- BMX DAI 1603 Input Modules 147
 - Introduction 147
 - Characteristics 148

Connecting the Module	150
BMX DAI 1604 Input Modules	153
Introduction	153
Characteristics	154
Connecting the Module	156
BMX DAI 1614 / BMX DAI 16142 Input Modules	159
Introduction	159
Characteristics	160
Connecting the Module	164
BMX DAI 1615 Input Modules	169
Introduction	169
Characteristics	170
Connecting the Module	172
BMX DAI 0805 Input Modules	177
Introduction	177
Characteristics	178
Connecting the Module	180
BMX DAI 0814 Input Module	183
Introduction	183
Characteristics	184
Connecting the Module	185
BMX DDI 3202 K Input Modules	188
Introduction	188
Characteristics	189
Connecting the Module	191
BMX DDI 6402 K Input Modules	195
Introduction	195
Characteristics	196
Connecting the Module	198
BMX DDO 1602 Static Output Modules	202
Introduction	202
Characteristics	203
Connecting the Module	205
BMX DDO 1612 Static Output Modules	208
Introduction	208

Characteristics	209
Connecting the Module	211
BMX DRA 0804T Relay Output Modules	214
Introduction	214
Characteristics	215
Connecting the Module	216
BMX DRA 0805 Relay Output Modules	219
Introduction	219
Characteristics	220
Connecting the Module	222
BMX DRA 0815 Relay Output Modules	225
Introduction	225
Characteristics	226
Connecting the Module	229
BMX DRA 1605 Relay Output Modules	232
Introduction	232
Characteristics	233
Connecting the Module	235
BMX DRC 0805 Relay Output Modules	238
Introduction	238
Characteristics	239
Connecting the Module	242
BMX DDO 3202 K Static Output Modules	245
Introduction	245
Characteristics	246
Connecting the Module	248
BMX DDO 6402 K Static Output Modules	251
Introduction	251
Characteristics	252
Connecting the Module	254
BMX DAO 1605 Triac Output Modules	257
Introduction	257
Characteristics	258
Connecting the Module	260
BMX DAO 1615 Isolated Triac Output Modules	263

Introduction	263
Characteristics	264
Connecting the Module	267
BMX DDM 16022 Mixed Static Input/Output Module	271
Introduction	271
Characteristics	272
Connecting the Module	276
BMX DDM 16025 Mixed Relay Input/Output module	281
Introduction	281
Characteristics	282
Connecting the Module	286
BMX DDM 3202 K Mixed Static Input/Output Module	290
Introduction	290
Characteristics	291
Connecting the Module	294
TELEFAST 2 Connection Interface Links for the Discrete I/O Modules	298
Introduction to the TELEFAST 2 Connection Interfaces for Discrete I/O	298
General Overview of TELEFAST 2 Connection Interfaces for Discrete I/O Modules	299
TELEFAST 2 Connection Bases Catalog	299
Combination of Discrete I/O Modules and TELEFAST 2 Connection Bases	306
Connection Principles for the TELEFAST 2 Interfaces for Discrete I/O	307
Connecting a Discrete Input/Output Module to a TELEFAST 2 Base Interface	307
Dimensions and Mounting of the TELEFAST 2 Connection Bases	309
TELEFAST 2 ABE-7H08R10/08R11 and ABE-7H16R10/16R11 Connection Bases	313
Sensor and Pre-actuator Connections on the ABE-7H08R10/R11 and ABE-7H16R10/R11 Bases	313
TELEFAST 2 ABE-7H12R10/12R11 Connection Bases	314
Sensor and Pre-actuator Connections on the ABE-7H12R10/R11 Bases	314
TELEFAST 2 ABE-7H08R21 and ABE-7H16R20/16R21/16R23 Connection Bases	316

Sensor and Pre-actuator Connections on the ABE-7H08R21 and ABE-7H16R20/R21/R23 Bases for Type 2 Inputs	316
TELEFAST 2 ABE-7H12R20/12R21 Connection Bases.....	318
Sensor and Pre-actuator Connections on the ABE-7H12R20/12R21 Bases	318
TELEFAST 2 ABE-7H08S21/16S21 Connection Bases	319
Sensor and Pre-actuator Connections on ABE-7H08S21/16S21 Bases with One Isolator per Channel.....	320
TELEFAST 2 ABE-7H12S21 Connection Base	321
Sensor and Pre-actuator Connections on the ABE-7H12S21 Base with 1 Isolator per Channel.....	322
TELEFAST 2 ABE-7H16R30/16R31 Connection Bases.....	323
Sensor and Pre-actuator Connections on the ABE-7H16R30/R31 Bases	324
TELEFAST 2 ABE-7H12R50 Connection Base	325
Sensor and Pre-actuator Connections on the ABE-7H12R50 Bases	326
TELEFAST 2 ABE-7H16R50 Connection Base	327
Sensor and Actuator Connections on the ABE-7H16R50 Base.....	327
TELEFAST 2 ABE-7H16F43 Connection Base	329
Actuator Connections on ABE-7H16F43 Output Base with One Fuse and One isolator per Channel.....	329
TELEFAST 2 ABE-7H16S43 Connection Base	330
Sensor Connections on ABE-7H16S43 Output Base with One Fuse and One Isolator per Channel.....	330
TELEFAST 2 Connection Base Accessories	332
TELEFAST 2 Connection Base Accessories Catalog	332
Association Table for the Relays on ABE-7R16Txxx, ABE-7P16Txxx and ABE-7P16Fxxx Bases.....	334
Characteristics of the Removable ABR-7xxx Electromechanical Output Relays	336
Characteristics of the Removable ABS-7Exx Static input Relays	337
Characteristics of the Removable ABS-7Sxx Static Output Relays.....	338
Discrete Input/Output Modules Software Implementation	339
General Introduction to the Application-Specific Discrete Function	340
Overview	340

Configuration	342
Configuration of a Discrete Module: General Points.....	342
Discrete Module Configuration Screen in Modicon Mx80 local rack.....	342
Discrete Module Configuration Screen in X80 Drop	344
Discrete Input and Output Channel Parameters	347
Discrete Input Parameters on the Rack.....	347
Discrete Output Parameters for 8-Channel Modules in Rack	348
Configuration of Discrete Module Parameters	350
How to Modify the Task Parameter	350
How to Modify the External Power Supply Error Monitoring Parameter	351
How to Modify the Fallback Mode Parameter	351
How to Modify the Output Reset Parameter	352
Application-Specific Discrete Module Language Objects	354
Language Objects and IODDT.....	354
Description of the Discrete Function Objects Languages.....	354
Discrete Module IODDTs and Device DDTs	355
IODDT Links.....	355
Details About T_DIS_IN_GEN Type IODDT Implicit Object Exchange.....	356
Details About T_DIS_IN_STD Type IODDT Implicit Object Exchange	357
Details About T_DIS_IN_STD Type IODDT Explicit Object Exchange.....	358
Details About T_DIS_OUT_GEN Type IODDT Implicit Object Exchange.....	359
Details About T_DIS_OUT_STD Type IODDT Implicit Object Exchange.....	360
Details About T_DIS_OUT_STD Type IODDT Explicit Object Exchange.....	361
Details of the Language Objects of the IODDT of Type T_GEN_MOD	362
Modicon X80 Discrete I/O Module Configuration Constants.....	364
Discrete Device DDT Names	365
MOD_FLT Byte Description	370
Debugging.....	371
Introduction to the Debugging Function of a Discrete Module	371

Debugging Screen.....	371
How to Access the Forcing/Unforcing Function	373
How to Access the SET and RESET Commands.....	374
How to Access the Reactivation of Outputs Command	375
Applied Outputs of a Discrete Module	375
Diagnostics of the Modules	376
How to Access the Diagnostics Function	376
How to Access the Channel Diagnostics Function of a Discrete Module.....	377
Appendices.....	379
Topological/State RAM Addressing of the Modules	380
Topological/State RAM Addressing of ModiconX80 Discrete Modules.....	380
Glossary.....	385
Index.....	387

Safety Information

Important Information

Read these instructions carefully, and look at the equipment to become familiar with the device before trying to install, operate, service, or maintain it. The following special messages may appear throughout this documentation or on the equipment to warn of potential hazards or to call attention to information that clarifies or simplifies a procedure.



The addition of this symbol to a “Danger” or “Warning” safety label indicates that an electrical hazard exists which will result in personal injury if the instructions are not followed.



This is the safety alert symbol. It is used to alert you to potential personal injury hazards. Obey all safety messages that follow this symbol to avoid possible injury or death.

DANGER

DANGER indicates a hazardous situation which, if not avoided, **will result in** death or serious injury.

WARNING

WARNING indicates a hazardous situation which, if not avoided, **could result in** death or serious injury.

CAUTION

CAUTION indicates a hazardous situation which, if not avoided, **could result in** minor or moderate injury.

NOTICE

NOTICE is used to address practices not related to physical injury.

Please Note

Electrical equipment should be installed, operated, serviced, and maintained only by qualified personnel. No responsibility is assumed by Schneider Electric for any consequences arising out of the use of this material.

A qualified person is one who has skills and knowledge related to the construction and operation of electrical equipment and its installation, and has received safety training to recognize and avoid the hazards involved.

Before You Begin

Do not use this product on machinery lacking effective point-of-operation guarding. Lack of effective point-of-operation guarding on a machine can result in serious injury to the operator of that machine.

▲ WARNING

UNGUARDED EQUIPMENT

- Do not use this software and related automation equipment on equipment which does not have point-of-operation protection.
- Do not reach into machinery during operation.

Failure to follow these instructions can result in death, serious injury, or equipment damage.

This automation equipment and related software is used to control a variety of industrial processes. The type or model of automation equipment suitable for each application will vary depending on factors such as the control function required, degree of protection required, production methods, unusual conditions, government regulations, etc. In some applications, more than one processor may be required, as when backup redundancy is needed.

Only you, the user, machine builder or system integrator can be aware of all the conditions and factors present during setup, operation, and maintenance of the machine and, therefore, can determine the automation equipment and the related safeties and interlocks which can be properly used. When selecting automation and control equipment and related software for a particular application, you should refer to the applicable local and national standards and regulations. The National Safety Council's Accident Prevention Manual (nationally recognized in the United States of America) also provides much useful information.

In some applications, such as packaging machinery, additional operator protection such as point-of-operation guarding must be provided. This is necessary if the operator's hands and other parts of the body are free to enter the pinch points or other hazardous areas and

serious injury can occur. Software products alone cannot protect an operator from injury. For this reason the software cannot be substituted for or take the place of point-of-operation protection.

Ensure that appropriate safeties and mechanical/electrical interlocks related to point-of-operation protection have been installed and are operational before placing the equipment into service. All interlocks and safeties related to point-of-operation protection must be coordinated with the related automation equipment and software programming.

NOTE: Coordination of safeties and mechanical/electrical interlocks for point-of-operation protection is outside the scope of the Function Block Library, System User Guide, or other implementation referenced in this documentation.

Start-up and Test

Before using electrical control and automation equipment for regular operation after installation, the system should be given a start-up test by qualified personnel to verify correct operation of the equipment. It is important that arrangements for such a check be made and that enough time is allowed to perform complete and satisfactory testing.

▲ WARNING

EQUIPMENT OPERATION HAZARD

- Verify that all installation and set up procedures have been completed.
- Before operational tests are performed, remove all blocks or other temporary holding means used for shipment from all component devices.
- Remove tools, meters, and debris from equipment.

Failure to follow these instructions can result in death, serious injury, or equipment damage.

Follow all start-up tests recommended in the equipment documentation. Store all equipment documentation for future references.

Software testing must be done in both simulated and real environments.

Verify that the completed system is free from all short circuits and temporary grounds that are not installed according to local regulations (according to the National Electrical Code in the U.S.A, for instance). If high-potential voltage testing is necessary, follow recommendations in equipment documentation to prevent accidental equipment damage.

Before energizing equipment:

- Remove tools, meters, and debris from equipment.
- Close the equipment enclosure door.

- Remove all temporary grounds from incoming power lines.
- Perform all start-up tests recommended by the manufacturer.

Operation and Adjustments

The following precautions are from the NEMA Standards Publication ICS 7.1-1995 (English version prevails):

- Regardless of the care exercised in the design and manufacture of equipment or in the selection and ratings of components, there are hazards that can be encountered if such equipment is improperly operated.
- It is sometimes possible to misadjust the equipment and thus produce unsatisfactory or unsafe operation. Always use the manufacturer's instructions as a guide for functional adjustments. Personnel who have access to these adjustments should be familiar with the equipment manufacturer's instructions and the machinery used with the electrical equipment.
- Only those operational adjustments actually required by the operator should be accessible to the operator. Access to other controls should be restricted to prevent unauthorized changes in operating characteristics.

About the Book

Document Scope

This manual describes the hardware and software installation of Modicon X80 discrete modules.

Validity Note

This documentation is valid for EcoStruxure™ Control Expert 15.0 or later.

The technical characteristics of the devices described in the present document also appear online. To access the information online, go to the Schneider Electric home page www.se.com/ww/en/download/.

The characteristics that are described in the present document should be the same as those characteristics that appear online. In line with our policy of constant improvement, we may revise content over time to improve clarity and accuracy. If you see a difference between the document and online information, use the online information as your reference.

Related Documents

Title of documentation	Reference number
Modicon M580, M340, and X80 I/O Platforms, Standards and Certifications	EIO0000002726 (English), EIO0000002727 (French), EIO0000002728 (German), EIO0000002730 (Italian), EIO0000002729 (Spanish), EIO0000002731 (Chinese)
EcoStruxure™ Control Expert, Operating Modes	33003101 (English), 33003102 (French), 33003103 (German), 33003104 (Spanish), 33003696 (Italian), 33003697 (Chinese)
EcoStruxure™ Control Expert, Program Languages and Structure, Reference Manual	35006144 (English), 35006145 (French), 35006146 (German), 35013361 (Italian), 35006147 (Spanish), 35013362 (Chinese)
EcoStruxure™ Control Expert, Communication, Block Library	33002527 (English), 33002528 (French), 33002529 (German), 33003682 (Italian), 33002530 (Spanish), 33003683 (Chinese)

Title of documentation	Reference number
EcoStruxure™ Control Expert, I/O Management, Block Library	33002531 (English), 33002532 (French), 33002533 (German), 33003684 (Italian), 33002534 (Spanish), 33003685 (Chinese)
EcoStruxure™ Control Expert, Concept Application Converter, User Manual	33002515 (English), 33002516 (French), 33002517 (German), 33003676 (Italian), 33002518 (Spanish), 33003677 (Chinese)

You can download these technical publications, the present document and other technical information from our website www.se.com/en/download/.

Product Related Information

▲ WARNING
<p>UNINTENDED EQUIPMENT OPERATION</p> <ul style="list-style-type: none"> • The application of this product requires expertise in the design and programming of control systems. Only persons with such expertise should be allowed to program, install, alter, and apply this product. • Follow all local and national safety codes and standards. <p>Failure to follow these instructions can result in death, serious injury, or equipment damage.</p>

Hardware Installation of the Discrete I/O Modules

What's in This Part

General Introduction	18
General Rules for Installing the Modules	37
Discrete Input/Output Module Diagnostic Processing	91
BMX DDI 1602 Input Modules	102
BMX DDI 1603 Input Modules	109
BMX DDI 1604T Input Modules	116
BMX DDI 3203 Input Modules	124
BMX DDI 3232 Input Modules	131
BMX DAI 1602 Input Modules	139
BMX DAI 1603 Input Modules	147
BMX DAI 1604 Input Modules	153
BMX DAI 1614 / BMX DAI 16142 Input Modules	159
BMX DAI 1615 Input Modules	169
BMX DAI 0805 Input Modules	177
BMX DAI 0814 Input Module	183
BMX DDI 3202 K Input Modules	188
BMX DDI 6402 K Input Modules	195
BMX DDO 1602 Static Output Modules	202
BMX DDO 1612 Static Output Modules	208
BMX DRA 0804T Relay Output Modules	214
BMX DRA 0805 Relay Output Modules	219
BMX DRA 0815 Relay Output Modules	225
BMX DRA 1605 Relay Output Modules	232
BMX DRC 0805 Relay Output Modules	238
BMX DDO 3202 K Static Output Modules	245
BMX DDO 6402 K Static Output Modules	251
BMX DAO 1605 Triac Output Modules	257
BMX DAO 1615 Isolated Triac Output Modules	263
BMX DDM 16022 Mixed Static Input/Output Module	271
BMX DDM 16025 Mixed Relay Input/Output module	281
BMX DDM 3202 K Mixed Static Input/Output Module	290
TELEFAST 2 Connection Interface Links for the Discrete I/O Modules	298

Subject of this Part

This part presents the range of Modicon X80 discrete I/O modules.

General Introduction

What's in This Chapter

General Description of the Modules.....	18
Physical Description of Discrete Modules with 20-pin Terminal Block Connection.....	19
Physical Description of Discrete Modules with 40-pin Terminal Block Connection.....	21
Physical Description of Discrete Modules with 40-Pin Connectors.....	22
Discrete Input Modules Catalog	23
Discrete Output Modules Catalog.....	26
Discrete Mixed Input/Output Modules Catalog.....	29
Dimensions of X80 Discrete I/O Modules	31
Temperature Derating	34
Standards and Certifications.....	36

Subject of this Section

This chapter provides a general introduction to discrete input/output modules.

General Description of the Modules

At a Glance

The discrete input/output modules of the Modicon X80 range are standard format modules (occupying one single position), fitted with either:

- one 20-pin terminal block or
- one 40-pin terminal block or
- one or two 40-pin connectors

For modules fitted with 40-pin connector outputs, a series of products known as TELEFAST 2, page 298 is available that enables discrete input/output modules to be quickly connected to operational parts.

A wide range of discrete inputs and outputs make it possible to meet the following requirements:

- functional: direct or alternating inputs/outputs, with positive or negative logic
- modularity: 8, 16, 32, or 64 channels per module

Inputs

Inputs receive signals from the sensors and carry out the following functions:

- acquisition
- adaptation
- galvanic insulation
- filtering
- protection against interference

Outputs

Outputs store the orders given by the processor, in order to control pre-actuators via decoupling and amplification circuits.

Physical Description of Discrete Modules with 20-pin Terminal Block Connection

At a Glance

The I/O modules are housed in plastic cases which provide IP20 protection for all the electronic parts.

Illustration

The diagram below shows a 20-pin discrete module and a 20-pin terminal block.

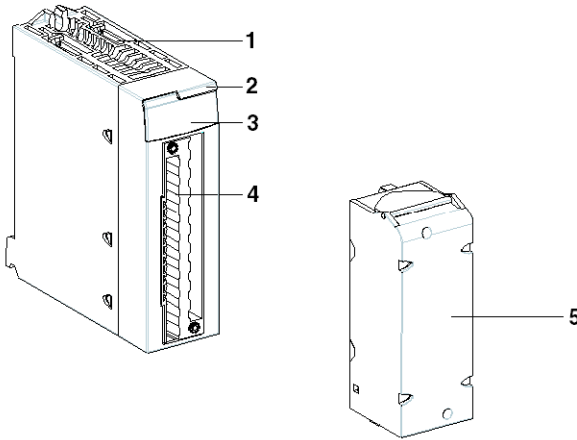

Elements

The following table describes the different elements of the discrete input/output modules with 20-pin terminal block connections.

Number	Description
1	Rigid structure which supports and protects the electronic card
2	Module reference label Note: A label is also visible on the right-hand side of the module.
3	Channel status display panel
4	Connector housing the 20-pin terminal block
5	20-pin terminal block, used to connect sensors or pre-actuators

NOTE: Terminal blocks are supplied separately.

Physical Description of Discrete Modules with 40-pin Terminal Block Connection

At a Glance

The I/O modules are housed in plastic cases which provide IP20 protection for all the electronic parts.

Illustration

The diagram below shows a 40-pin discrete module and a 40-pin terminal block.

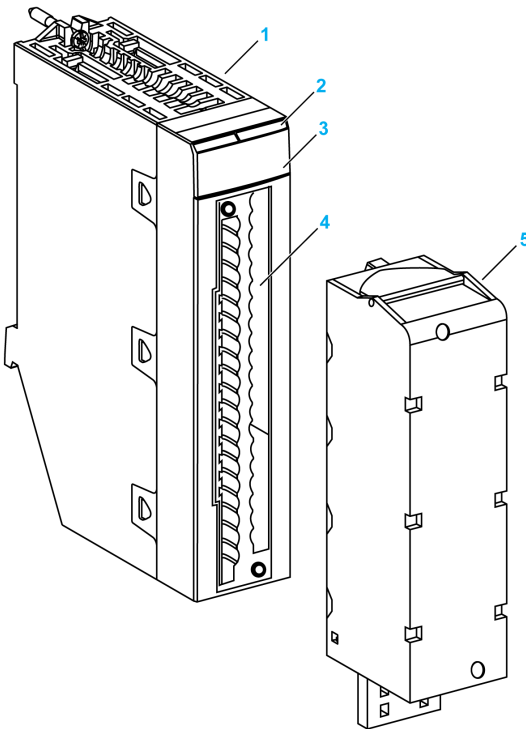

Elements

The following table describes the different elements of the discrete input/output modules with 40-pin terminal block connections.

Number	Description
1	Rigid structure which supports and protects the electronic card
2	Module reference label Note: A label is also visible on the right-hand side of the module.
3	Channel status display panel
4	Connector housing the 40-pin terminal block
5	40-pin terminal block, used to connect sensors or pre-actuators

NOTE: Terminal blocks are supplied separately.

Physical Description of Discrete Modules with 40-Pin Connectors

At a Glance

The input/output modules are housed in plastic cases which provide IP20 protection for all the electronic parts.

Illustration

The diagram below shows a 40-pin discrete module.

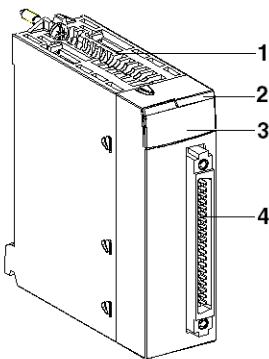

Elements

The following table describes the different elements of the discrete input/output modules by 40-pin connectors.

Number	Description
1	Rigid structure which supports and protects the electronic card
2	Module reference labels Note: A label is also visible on the right-hand side of the module.
3	Channel status display panel
4	40-pin connector, used to connect sensors or pre-actuators

Discrete Input Modules Catalog

At a Glance

The tables below present the two catalogs of discrete input modules:

- with 20-pin and 40-pin terminal blocks
- with 40-pin connectors

Catalog of Terminal Block Input Modules

Catalog of discrete input modules with 20-pin terminal block connection.

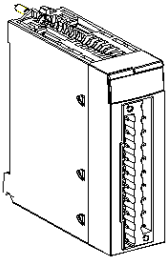
Type of module	Inputs with 20-pin terminal block connection							
Illustration	Discrete input module 							
Number of channels	16 inputs	16 inputs	16 inputs	16 inputs	16 inputs	16 inputs	8 inputs	8 inputs

Range	24 VDC	48 VDC	125 VDC	24 VAC	24 VDC	48 VAC	100...1-20 VAC	100...120 VAC	200...2-40 VAC
Insulation	Insulated inputs	Insulated inputs	Insulated inputs	Insulated inputs		Insulated inputs	Insulated inputs	channel to channel isolated inputs	Insulated inputs
IEC 61131-2 compliance	Type 3	Type 1	N/A	Type 1	N/A	Type 3	Type 3	Type 3	Type 2
Logic	Positive	Positive	Positive	N/A	Positive or Negative	N/A	N/A	N/A	N/A
Proximity sensor compatibility	2-wire DC and 3-wire PNP proximity sensor (IEC 60947-5-2 standard compliant)				N/A	2-wire DC and 3-wire PNP proximity sensor (IEC 60947-5-2 standard compliant)			
Response time	4 ms	4 ms	5 ms	15 ms		10 ms	10 ms	10 ms	10 ms
Type of Interface	20-pin terminal block	20-pin terminal block	20-pin terminal block	20-pin terminal block		20-pin terminal block	20-pin terminal block	20-pin terminal block	20-pin terminal block
Reference	BMX DDI 1602	BMX DDI 1603	BMX DDI 1604T	BMX DAI 1602		BMX DAI 1603	BMX DAI 1604	BMX DAI 0814	BMX DAI 0805

Catalog of discrete input modules with 40-pin terminal block connection.

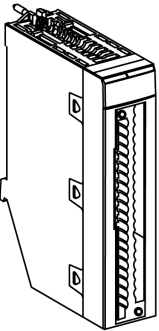
Type of module	Inputs with 40-pin terminal block connection			
Illustration	<p>Discrete input module</p> 			
Number	16 inputs	16 inputs	32 inputs	32 inputs

of channels				
Range	100...120 VAC	200...240 VAC	48 VDC	12/24 VDC
Insulation	channel to channel isolated inputs	channel to channel isolated inputs	Inputs insulated per group of 16 channels	Inputs insulated per group of 16 channels
IEC 6113-1-2 compliance	Type 1	Type 1	Type 3	Type 3 (24 VDC input)
Logic	N/A	N/A	Positive	Positive or Negative
Proximity sensor compatibility	2-wire and 3-wire proximity sensor (IEC 60947-5-2 standard compliant)		2-wire proximity sensor 3-wire PNP proximity sensor	N/A
Response time	10 ms	10 ms	4 ms	4 ms
Type of Interface	40-pin terminal block	40-pin terminal block	40-pin terminal block	40-pin terminal block
Reference	BMX DAI 1614	BMX DAI 1615	BMX DDI 3203	BMX DDI 3232

Catalog of 40-pin Connector Input Modules

Catalog of discrete input modules with 40-pin connectors.

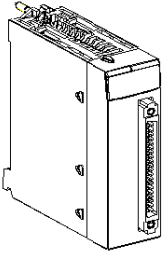
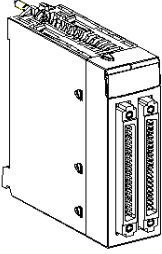
Type of module	Inputs with connection via 40-pin connectors	
Illustration	Discrete input module 	Discrete input module 
Number of channels	32 inputs	64 inputs
Range	24 VDC	24 VDC
Insulation	Inputs insulated per group of 16 channels	Inputs insulated per group of 16 channels
IEC 61131-2 compliance	Type 1	No type
Logic	Positive	Positive
Proximity sensor compatibility	2-wire proximity sensor 3-wire PNP proximity sensor	3-wire PNP proximity sensor
Response time	4 ms	4 ms
Type of Interface	1 x 40-pin connector	2 x 40-pin connectors
Reference	BMX DDI 3202 K	BMX DDI 6402 K

Discrete Output Modules Catalog

At a Glance

The tables below show the catalogs of static and relay output modules.

Catalog of Output Modules

Catalog of discrete static output modules with connection via 20-pin terminal blocks and 40-pin connectors.

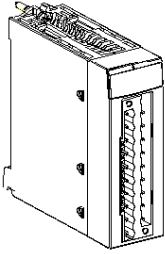
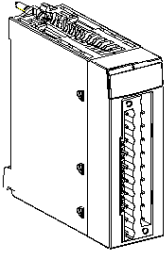
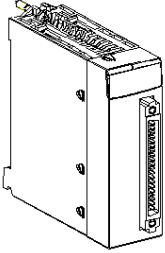
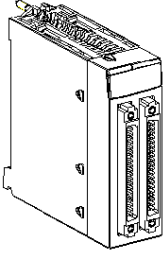
Type of module	Static outputs with 20-pin terminal block connections		Static outputs with 40-pin connectors	
Illustration 	Discrete output module 		Discrete output module 	Discrete output module 
Number of channels	16 outputs	16 outputs	32 outputs	64 outputs
Range	24 VDC	24 VDC	24 VDC	24 VDC
Insulation	Insulated outputs	Insulated outputs	Outputs insulated per group of 16 channels	
Current	0.5 A	0.5 A	0.1 A	0.1 A
Overload protection	Outputs protected against short-circuits and overloads with automatic or controlled reactivation and fast electromagnet demagnetization circuit.			
Logic	Positive	Negative	Positive	Positive
Response time	1.2 ms	1.2 ms	1.2 ms	1.2 ms
Type of Interface	20-pin terminal block	20-pin terminal block	1 x 40-pin connector	2 x 40-pin connectors
Reference	BMX DDO 1602	BMX DDO 1612	BMX DDO 3202 K	BMX DDO 6402 K

Catalog of Relay Output Modules

Catalog of discrete relay output modules with 20-pin and 40-pin terminal block connection.

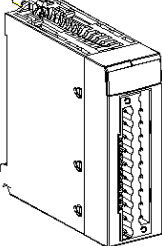
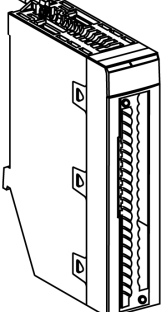
Type of module	Relay outputs with 20-pin terminal block connections				Relay outputs with 40-pin terminal block connections
Illustration	Discrete output module				Discrete output module
					
Number of channels	8 outputs	8 outputs	8 outputs	16 outputs	8 NO/NC outputs
Range	125 VDC	24 VDC or 24...240 VAC	5...125 VDC or 24...240 VAC	24...48 VDC or 24...240 VAC	5...125 VDC or 24...240 VAC
Insulation	Outputs insulated from ground	Outputs insulated from ground	Outputs insulated from ground	Outputs insulated from ground	Outputs insulated from ground
Type of contact	8 insulated channels	8 insulated channels	8 insulated channels	1 common per group of 8 channels	8 insulated channels
Thermal current per channel	3 A	3 A	2 A	2 A	4 A
Overload protection	No protection	No protection	No protection	No protection	No protection
Logic	Positive/negative	Positive/negative	Positive/negative	Positive/negative	Positive/negative
Response time	10 ms max	10 ms max	13 ms max	10 ms max	13 ms max
Type of interface	20-pin terminal block	20-pin terminal block	20-pin terminal block	20-pin terminal block	40-pin terminal block
Reference	BMX DRA 0804T	BMX DRA 0805	BMX DRA 0815	BMX DRA 1605	BMX DRC 0805

Catalog of Triac Output Module

Catalog of discrete triac output module with connection via 20-pin and 40-pin terminal blocks.

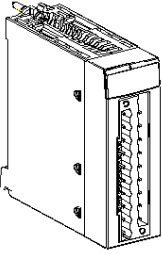
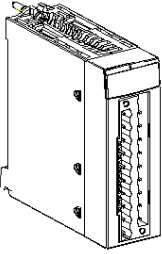
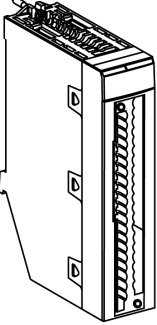
Type of module	Triac outputs with 20-pin terminal block connections	Triac outputs with 40-pin terminal block connections
Illustration 	Discrete output module 	Discrete output module 
Number of channels	16 outputs	16 outputs
Range	100...240 VAC	24...240 VAC
Insulation	Outputs insulated by group of 4 channels	Outputs individually insulated
Current	max: 0.6 A / points (with derating, page 34)	max: 3 A per channel (with derating, page 264)
Overload protection	Snubber circuit and varistor	Snubber circuit and varistor
Logic	-	-
Response time	1 ms + 0.5 x (1/F) (where F = frequency in Hz)	max: 0.5 x (1/F) (where F = frequency in Hz)
Type of Interface	20-pin terminal block	40-pin terminal block
Reference	BMX DAO 1605	BMX DAO 1615

Discrete Mixed Input/Output Modules Catalog

At a Glance

The table below presents the catalog of discrete mixed input/output modules with connections by 20-pin terminal block and by 40-pin connectors.

Catalog

Catalog of discrete mixed input/output modules with connection via 20-pin terminal blocks and 40-pin connectors.

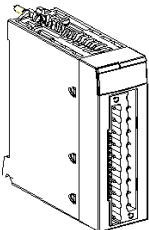
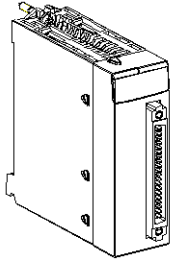
	Type of module	Mixed inputs/outputs with 20-pin terminal block connections		Mixed inputs/outputs with 40-pin terminal block connections
	Illustration	Discrete mixed input/output modules 		Discrete mixed input/output modules 
	Number of channels	8 inputs 8 outputs	8 inputs 8 outputs	16 inputs 16 outputs
Inputs	Range	24 VDC	24 VDC	24 VDC
	Insulation	Insulated inputs	Insulated inputs	Insulated inputs
	IEC 61131-2 compliant	Type 3	Type 3	Type 1
	Logic	Positive	Positive	Positive
	Response time	4 ms	4 ms	4 ms
Outputs	Range	Static outputs 24 VDC	Relay outputs 24 VDC or 24...240 VAC	Static outputs 24 VDC
	Insulation	Outputs insulated from ground	Outputs insulated from ground 1 common per group of 8 channels	Outputs insulated from ground
	Current	0.5 A	2 A	0.1 A
	IEC 61131-2 compliant	Yes	Yes	Yes
	Overload protection	Outputs are protected against overloads and short-circuits.	N/A	Outputs are protected against overloads and short-circuits.

	Logic	Positive	N/A	Positive
	Response time	1.2 ms	10 ms max	1.2 ms
	Connections	20-pin terminal block	20-pin terminal block	1 x 40-pin connector
	Reference	BMX DDM 16022	BMX DDM 16025	BMX DDM 3202 K

Dimensions of X80 Discrete I/O Modules

General Presentation of X80 Discrete I/O Modules

X80 Discrete I/O Module with a 20-pin removable terminal block

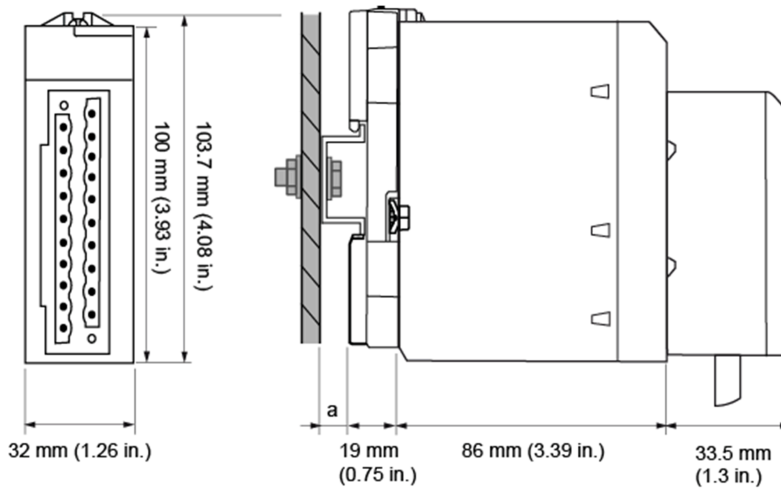

a DIN-rail depth: the value depends on the DIN-rail type used in your platform.

X80 Discrete I/O Module with a 40-pin removable terminal block

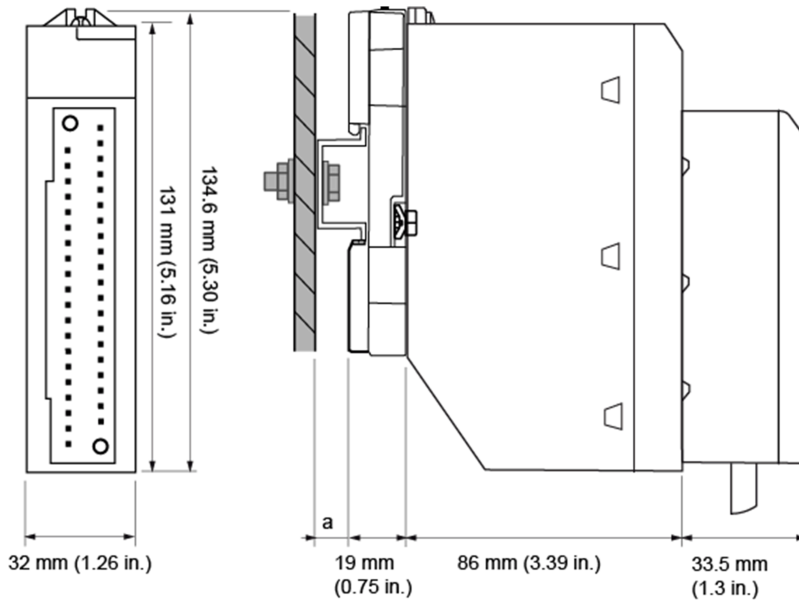

a DIN-rail depth: the value depends on the DIN-rail type used in your platform. Refer to *Mounting the Racks* (see Modicon X80, Racks and Power Supplies, Hardware Reference Manual).

X80 Discrete I/O Module with 40-pin FCN-type connectors

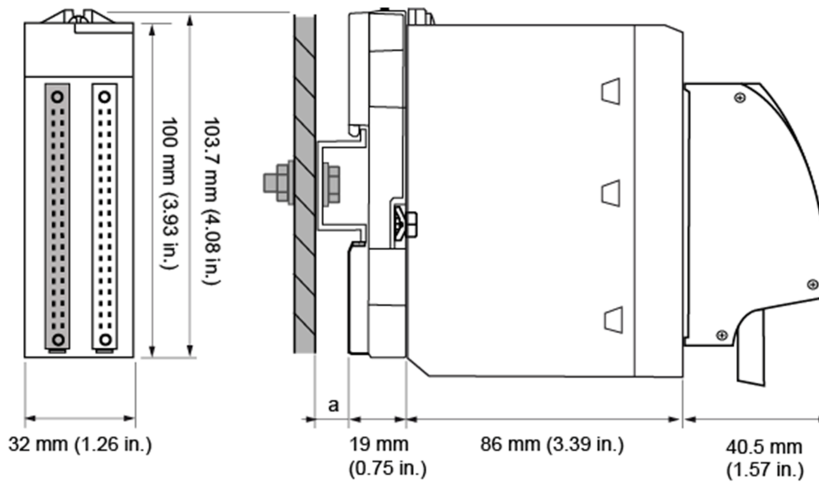

a DIN-rail depth: the value depends on the DIN-rail type used in your platform.

Dimensions of X80 Discrete Modules

Module reference	Module dimension			Installation depth ⁽¹⁾
	Width	Height	Module alone	
X80 Discrete I/O Modules with a 20-pin removable terminal block				
BMXDDI1602(H)	32 mm (1.26 in.)	103.7 mm (4.08 in.)	86 mm (3.39 in.)	119.5 mm (4.69 in.) ⁽¹⁾
BMXDDI1603(H)				
BMXDDI1604(T)				
BMXDAI1602(H)				
BMXDAI1603(H)				
BMXDAI1604(H)				
BMXDAI0805(H)				
BMXDAI0814				
BMXDDO1602(H)				
BMXDDO1612(H)				
BMXDRA0804(T)				
BMXDRA0805(H)				
BMXDRA0815(H)				
BMXDRA1605(H)				
BMXDAO1605(H)				
BMXDDM1622(H)				
BMXDDM1625(H)				
X80 Discrete I/O Modules with a 40-pin removable terminal block				
BMXDAI1614(H)	32 mm (1.26 in.)	134.6 mm (5.30 in.)	86 mm (3.39 in.)	119.5 mm (4.69 in.) ⁽¹⁾
BMXDAI1615(H)				
BMXDRC0805(H)				
BMXDAO1615(H)				
X80 Discrete I/O Modules with 1 or 2 40-pin FCN-type connectors				
BMXDDI3202(K)	32 mm (1.26 in.)	103.7 mm (4.08 in.)	86 mm (3.39 in.)	126.5 mm (4.96 in.) ⁽¹⁾
BMXDDI3202(KH)				
BMXDDO3202(K)				

Module reference	Module dimension			Installation depth ⁽¹⁾
	Width	Height	Module alone	
BMXDDO3202(KC)				
BMXDDM3202(K)				
BMXDDI6402(K)				
BMXDDI6402(KH)				
BMXDDO6402(K)				
BMXDDO6402(KC)				
(1) DIN-rail depth (a) is not included.				

NOTE: Connectors that are delivered with the X80 Discrete I/O modules (20-pin and 40-pin removable terminal blocks) and the corresponding pre-assembled cordsets (BMXFTW**1 and BMXFTW**5) have the same dimensions.

NOTE: Consider clearance for cable installation and spacing around the racks.

Temperature Derating

At a Glance

The characteristics are specified for a load rate of 60% of the channels.

⚠ CAUTION
OVERHEATING HAZARD
Take into account the temperature derating of the discrete I/O modules at the installation to prevent the device from overheating and/or deteriorating.
Failure to follow these instructions can result in injury or equipment damage.

If the rate is greater than 60%, the following downgrade curve must be taken into consideration.

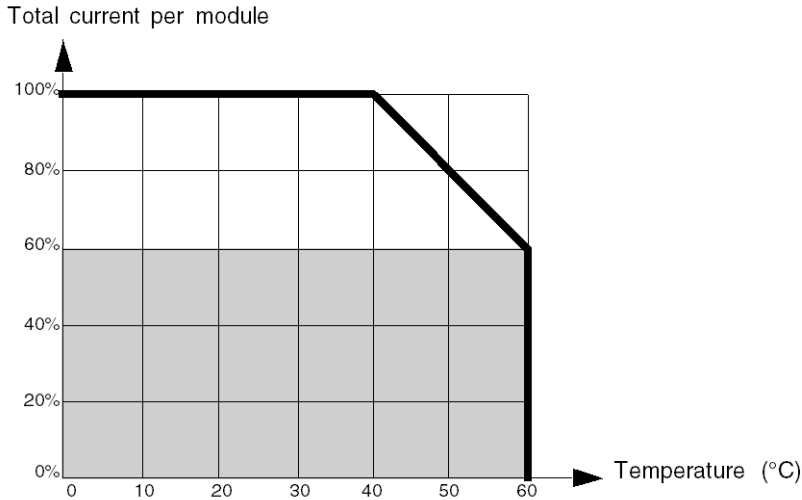

NOTE: There is no temperature derating for relay modules. Users must therefore check that the overall consumption of the 24 VDC power supply is sufficient.

NOTE: For static outputs, temperature derating is carried out on the basis of the maximum current produced by the active outputs.

Altitude Operating Conditions

The temperature derating applies to the modules for use at altitude up to 2000 m (6560 ft). When the modules operate above 2000 m (6560 ft), apply additional derating. For detailed information, refer to chapter *Operating and Storage Conditions* (see Modicon M580, M340, and X80 I/O Platforms, Standards and Certifications).

Examples

- **BMX DDO 1602**

Suppose the BMX DDO 1602 module with sixteen 24 VDC/0.5 A outputs produces 0.5 A per channel. For an ambient temperature reading of between 0°C and 40°C, the maximum admissible current in the module is equal to $16 \times 0.5 = 8$ A. Above 40°C, the downgrading curve must be applied. At 60°C, the maximum current in 24 VDC must not exceed $8 \times 60\% = 4.8$ A. This value corresponds to 10 outputs at 0.5 A or 16 outputs at 0.3 A or other combinations.

- **BMX DDO 6402**

Suppose the BMX DDO 6402 K module with sixty-four 24 VDC/0.1 A outputs produces 0.1 A per channel. For an ambient temperature reading of between 0°C and 40°C, the maximum admissible current in the module is equal to $64 \times 0.1 = 6.4$ A. Above 40°C, the downgrading curve must be applied. At 60°C, the maximum current in 24 VDC must not exceed $6.4 \times 60\% = 3.8$ A. This value corresponds to 38 outputs at 0.1 A or 64 outputs at 0.05 A or other combinations.

- **BMX DAO 1605**

Suppose the BMX DAO 1605 module with sixteen 220 VAC outputs producing 0.3 A per channel. For an ambient temperature reading of between 0°C and 40°C, the maximum admissible current in the module is equal to $16 \times 0.3 \text{ A} = 4.8$ A (2.4 A per 8-channel group maximum). Above 40°C, the downgrading curve must be applied. At 60°C, the maximum current in 220 Vac must not exceed $4.8 \text{ A} \times 0.6 = 2.9$ A (1.5 A per 8-channel group maximum). This value corresponds to 10 outputs at 0.3 A or to 16 outputs at 0.18 A.

Standards and Certifications

Download

Click the link that corresponds to your preferred language to download standards and certifications (PDF format) that apply to the modules in this product line:

Title	Languages
Modicon M580, M340, and X80 I/O Platforms, Standards and Certifications	<ul style="list-style-type: none"> • English: EIO0000002726 • French: EIO0000002727 • German: EIO0000002728 • Italian: EIO0000002730 • Spanish: EIO0000002729 • Chinese: EIO0000002731

General Rules for Installing the Modules

What's in This Chapter

Fitting of the Modules	37
20-pin Terminal Blocks: BMX FTB 20•0.....	40
40-pin Terminal Blocks: BMX FTB 40•0.....	43
BMX FTW ••1 Cable.....	49
BMX FTW ••5 Cable	53
Fitting a 20-pin Terminal Block to a Module	57
Fitting a 40-Pin Terminal Block to a Module.....	62
Fitting a 40-pin FCN Type Connector to a Module.....	67
Presentation for Choosing Power Supplies for Sensors and Pre-Actuators	68
Wiring Precautions.....	72
How to Connect Discrete Input/Output Modules: Connecting 40-Pin Connector Modules	76
How to Connect Discrete Input/Output Modules: Connecting 40-Pin Connector Modules to TELEFAST Interfaces.....	82
Sensor/Input Compatibility and Pre-actuator/Output Compatibility.....	87

Subject of this Section

This chapter presents the general rules for installing discrete input/output modules.

Fitting of the Modules

At a Glance

The discrete input/output modules are powered by the bus of the rack. The modules may be handled without turning off power supply to the rack, without damage or disturbance to the PLC.

Fitting operations (installation, assembly and disassembly) are described below.

Installation Precautions

The Modicon X80 discrete modules may be installed in any of the positions in the rack except:

- the positions reserved for the rack power supply modules (marked PS, PS1, and PS2),

- the positions reserved for extended modules (marked XBE),
- the positions reserved for the CPU in the main local rack (marked 00 or marked 00 and 01 depending on the CPU),
- the positions reserved for the (e)X80 adapter module in the main remote drop (marked 00).

Power is supplied by the bus at the bottom of the rack (3.3 V and 24 V).

Before installing a module, you must take off the protective cap from the module connector located on the rack.

DANGER

HAZARD OF ELECTRIC SHOCK, EXPLOSION OR ARC FLASH

Disconnect the power to the sensors and pre-actuators and disconnect the terminal block to carry out assembly and disassembly of the modules.

Failure to follow these instructions will result in death or serious injury.

Installation

The diagram below shows some discrete input/output modules mounted on the rack.

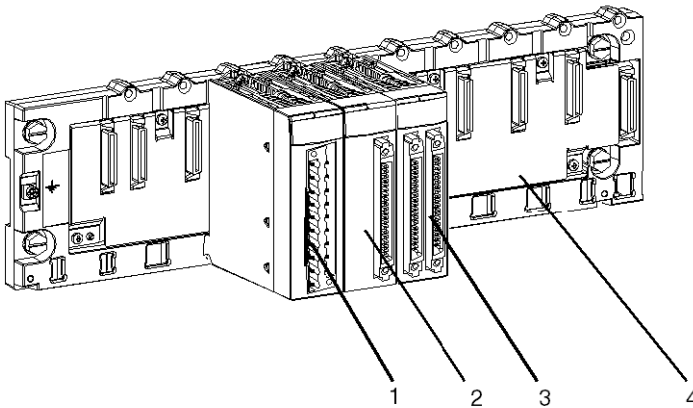

The following table describes the different elements which make up the assembly below.

Number	Description
1	20-pin terminal block module
2	40-pin connector module

Number	Description
3	2 x 40-pin connector module
4	Standard rack

Installing the Module on the Rack

The table below presents the procedure for mounting the discrete input/output modules on the rack:

Step	Action
1	Remove the protective cover from the connector of the module slot on the Modicon X80 rack.
2	Position the locating pins situated at the rear of the module (on the bottom part) in the corresponding slot in the rack.
3	Swivel the module towards the top of the rack so that the module sits flush with the back of the rack.
4	Tighten the mounting screw on top of the module to hold in place on the rack. Tightening torque: 0.4...1.5 N•m (0.30...1.10 lbf-ft).

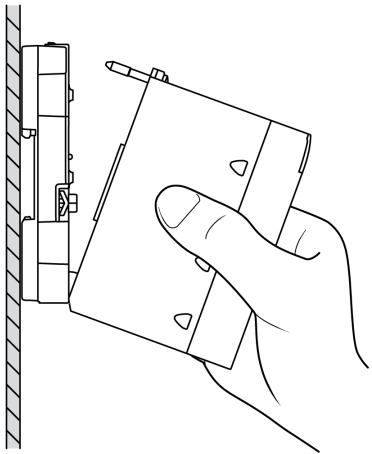

The diagram illustrates the final step of the installation process. A hand is shown from the right, holding a rectangular module and pushing it into a vertical slot on the left. The module is tilted upwards. A screw is visible on the top surface of the module, which is being tightened to secure it to the rack. The rack's internal structure, including a vertical guide rail, is partially visible.

▲ WARNING

UNINTENDED EQUIPMENT OPERATION

Check that the mounting screw is securely tightened to ensure the module is firmly attached to the rack.

Failure to follow these instructions can result in death, serious injury, or equipment damage.

20-pin Terminal Blocks: BMX FTB 20•0



At a Glance

There are three types of 20-pin terminal blocks:

- BMX FTB 2010 screw clamp terminal blocks
- BMX FTB 2000 caged terminal blocks
- BMX FTB 2020 spring terminal blocks

Cable Ends and Contacts







Each terminal block can accommodate:

- Bare wires
- Wires with:
 - DZ5-CE (ferrule) type cable ends: 
 - AZ5-DE (twin ferrule) type cable ends: 

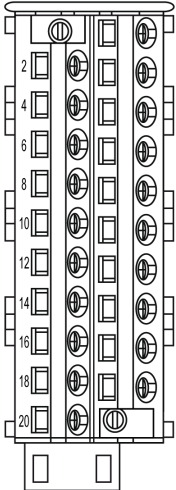
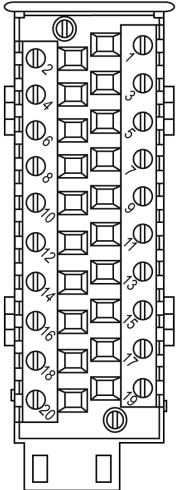
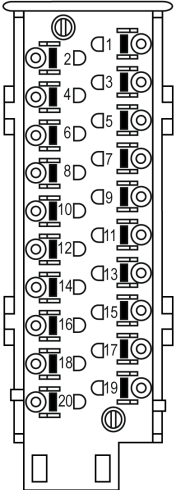
NOTE: When using stranded cable, Schneider Electric strongly recommends the use of wire ferrules which are fitted with an appropriate crimping tool.

Description of the 20-pin Terminal Blocks

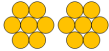
The following table describes the type of wires that fit each terminal block and the associated gauge range, wiring constraints, and tightening torque:

	Screw Clamp Terminal Blocks BMX FTB 2010	Caged Terminal Blocks BMX FTB 2000	Spring Terminal Blocks BMX FTB 2020
Illustration			
1 solid conductor 	<ul style="list-style-type: none"> • AWG: 22...16 • mm²: 0.34...1.5 	<ul style="list-style-type: none"> • AWG: 22...18 • mm²: 0.34...1 	<ul style="list-style-type: none"> • AWG: 22...18 • mm²: 0.34...1
2 solid conductors 	<p>2 conductors of the same size:</p> <ul style="list-style-type: none"> • AWG: 2 x 22...16 • mm²: 2 x 0.34...1.5 	<p>Only possible with twin ferrule:</p> <ul style="list-style-type: none"> • AWG: 2 x 24...20 • mm²: 2 x 0.24...0.75 	<p>Only possible with twin ferrule:</p> <ul style="list-style-type: none"> • AWG: 2 x 24...20 • mm²: 2 x 0.24...0.75
1 stranded cable 	<ul style="list-style-type: none"> • AWG: 22...16 • mm²: 0.34...1.5 	<ul style="list-style-type: none"> • AWG: 22...18 • mm²: 0.34...1 	<ul style="list-style-type: none"> • AWG: 22...18 • mm²: 0.34...1
2 stranded cables 	<p>2 conductors of the same size:</p> <ul style="list-style-type: none"> • AWG: 2 x 22...16 • mm²: 2 x 0.34...1.5 	<p>Only possible with twin ferrule:</p> <ul style="list-style-type: none"> • AWG: 2 x 24...20 • mm²: 2 x 0.24...0.75 	<p>Only possible with twin ferrule:</p> <ul style="list-style-type: none"> • AWG: 2 x 24...20 • mm²: 2 x 0.24...0.75
1 stranded cable with ferrule 	<ul style="list-style-type: none"> • AWG: 22...16 • mm²: 0.34...1.5 	<ul style="list-style-type: none"> • AWG: 22...18 • mm²: 0.34...1 	<ul style="list-style-type: none"> • AWG: 22...18 • mm²: 0.34...1
2 stranded cables with twin ferrule 	<ul style="list-style-type: none"> • AWG: 2 x 24...18 • mm²: 2 x 0.24...1 	<ul style="list-style-type: none"> • AWG: 2 x 24...20 • mm²: 2 x 0.24...0.75 	<ul style="list-style-type: none"> • AWG: 2 x 24...20 • mm²: 2 x 0.24...0.75

	Screw Clamp Terminal Blocks BMX FTB 2010	Caged Terminal Blocks BMX FTB 2000	Spring Terminal Blocks BMX FTB 2020
Minimum individual wire size in stranded cables when a ferrule is not used 	<ul style="list-style-type: none"> • AWG: 30 • mm²: 0.0507 	<ul style="list-style-type: none"> • AWG: 30 • mm²: 0.0507 	<ul style="list-style-type: none"> • AWG: 30 • mm²: 0.0507
Wiring constraints	Screw clamps have slots that accept: <ul style="list-style-type: none"> • Flat-tipped screwdrivers with a diameter of 5 mm. • Pozidriv PZ1 or Philips PH1 cross-tipped screwdrivers. Screw clamp terminal blocks have captive screws. On the supplied blocks, these screws are not tightened.	Caged terminal blocks have slots that accept: <ul style="list-style-type: none"> • Flat-tipped screwdrivers with a diameter of 3 mm. Caged terminal blocks have captive screws. On the supplied blocks, these screws are not tightened.	The wires are connected by pressing the button located next to each pin. To press the button, use a flat-tipped screwdriver with a maximum diameter of 3 mm.
Screw tightening torque	0.5 N•m (0.37 lbf-ft)	0.4 N•m (0.30 lbf-ft)	Not applicable

Connection of 20-pin Terminal Blocks



DANGER

HAZARD OF ELECTRIC SHOCK

Turn off all power to sensor and pre-actuator devices before connection or disconnection of the terminal block.

Failure to follow these instructions will result in death or serious injury.

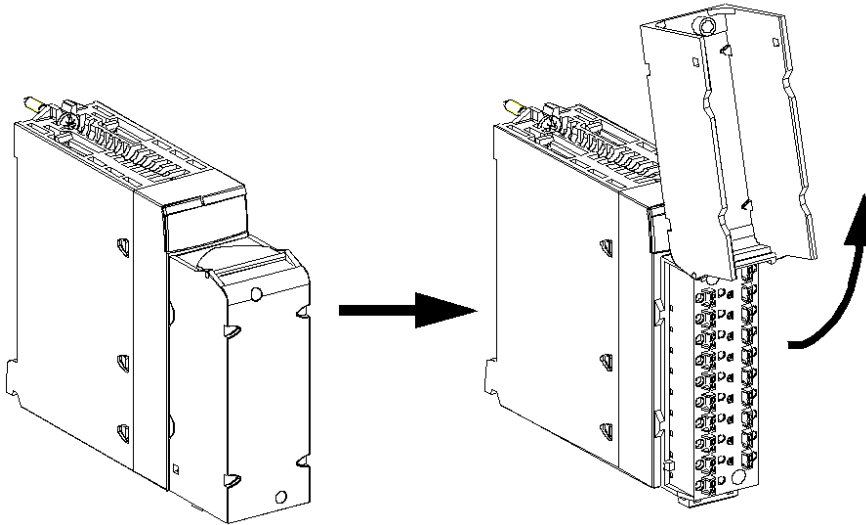
The following diagram shows the method for opening the 20-pin terminal block door so that it can be wired:



NOTE: The connection cable is installed and held in place by a cable clamp positioned below the 20-pin terminal block.

Labeling of 20-pin Terminal Blocks

Labels for the 20-pin terminal blocks are supplied with the module. They are to be inserted in the terminal block cover by the customer.

Each label has two sides:

- One side that is visible from the outside when the cover is closed. This side features the commercial product references, an abbreviated description of the module, as well as a blank section for customer labeling.
- One side that is visible from the inside when the cover is open. This side shows the terminal block connection diagram.

40-pin Terminal Blocks: BMX FTB 40•0

At a Glance

There are two versions, available in two types of 40-pin terminal blocks:

Standard version	<ul style="list-style-type: none"> • BMX FTB 4000 caged terminal block • BMX FTB 4020 spring terminal block
Hardened version	<ul style="list-style-type: none"> • BMX FTB 4000H caged terminal block with gold plating • BMX FTB 4020H spring terminal block with gold plating

The hardened version of the terminal blocks are only dedicated to the hardened version of the modules.

NOTE: If you mix hardened and standard versions when fitting the terminal block to the module, there is a risk of terminal pin corrosion and a signal deviation.

⚠ WARNING

UNINTENDED EQUIPMENT OPERATION

- Do not use the hardened version of the terminal block with a standard module.
- Do not use the standard version of the terminal block with a hardened module.

Failure to follow these instructions can result in death, serious injury, or equipment damage.

There are also preassembled cordsets with a BMX FTB 4020 terminal block at one end and flying leads at the other. The cordsets are available under reference BMX FTW ••5, page 55.

Cable Ends and Contacts

The 40-pin terminal blocks are designed for only one wire or one cable end.

Each terminal block can accommodate:

- Bare wires:
 - Solid conductor
 - Stranded cable
- Wires with ferrule (DZ5CE••••/DZ5CA•••• single type cable ends): 

NOTE: When using stranded cable, Schneider Electric strongly recommends the use of wire ferrules which are fitted with an appropriate crimping tool.

Jumper bar

To facilitate the wiring, a 20-pin jumper bar with plastic handle is provided with 40-pin caged screw terminal block BMX FTB 4000:

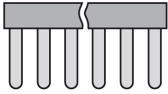

The following graphic shows an example of using the jumper bar for non-isolated wiring channel 0-2 with on a BMX DRC 0805 module:

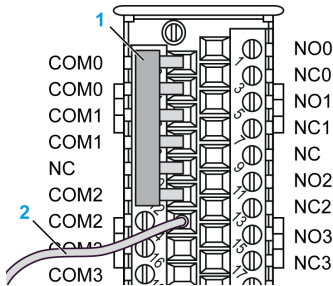

1 Jumper bar

2 to common

⚠ CAUTION

UNINTENDED EQUIPMENT OPERATION

Do not exceed the maximum capability of a single point of the terminal block when using it to carry the whole common current:

- 10 A maximum for a single point of the BMXFTB4000 terminal block
- 8 A maximum for a single point of the BMXFTB4020 terminal block

Failure to follow these instructions can result in injury or equipment damage.

Description of the 40-pin Terminal Blocks

The following table describes the type of wires that fit each terminal block and the associated gauge range, wiring constraints, and tightening torque:

	Caged Terminal Blocks BMX FTB 4000	Spring Terminal Blocks BMX FTB 4020
Illustration		
1 solid conductor 	<ul style="list-style-type: none"> • AWG: 26...18 • mm²: 0.13...1 	<ul style="list-style-type: none"> • AWG: 26...18 • mm²: 0.13...1
1 stranded cable 	<ul style="list-style-type: none"> • AWG: 22...18 • mm²: 0.34...1 	<ul style="list-style-type: none"> • AWG: 22...18 • mm²: 0.34...1
1 stranded cable with ferrule 	<ul style="list-style-type: none"> • AWG: 22...18 • mm²: 0.34...1 	<ul style="list-style-type: none"> • AWG: 22...18 • mm²: 0.34...1
Minimum individual wire size in stranded cables when a ferrule is not used 	<ul style="list-style-type: none"> • AWG: 30 • mm²: 0.0507 	<ul style="list-style-type: none"> • AWG: 30 • mm²: 0.0507

	Caged Terminal Blocks BMX FTB 4000	Spring Terminal Blocks BMX FTB 4020
Wiring constraints	<p>Caged terminal blocks have slots that accept:</p> <ul style="list-style-type: none"> Flat-tipped screwdrivers with a diameter of 3 mm. <p>Caged terminal blocks have captive screws. On the supplied blocks, these screws are not tightened.</p>	<p>The wires are connected by pressing the button located next to each pin.</p> <p>To press the button, use a flat-tipped screwdriver with a maximum diameter of 3 mm.</p>
Screw tightening torque	0.4 N•m (0.30 lbf-ft)	Not applicable

Connection of 40-pin Terminal Blocks



DANGER

HAZARD OF ELECTRIC SHOCK

Turn off all power to sensor and pre-actuator devices before connection or disconnection of the terminal block.

Failure to follow these instructions will result in death or serious injury.

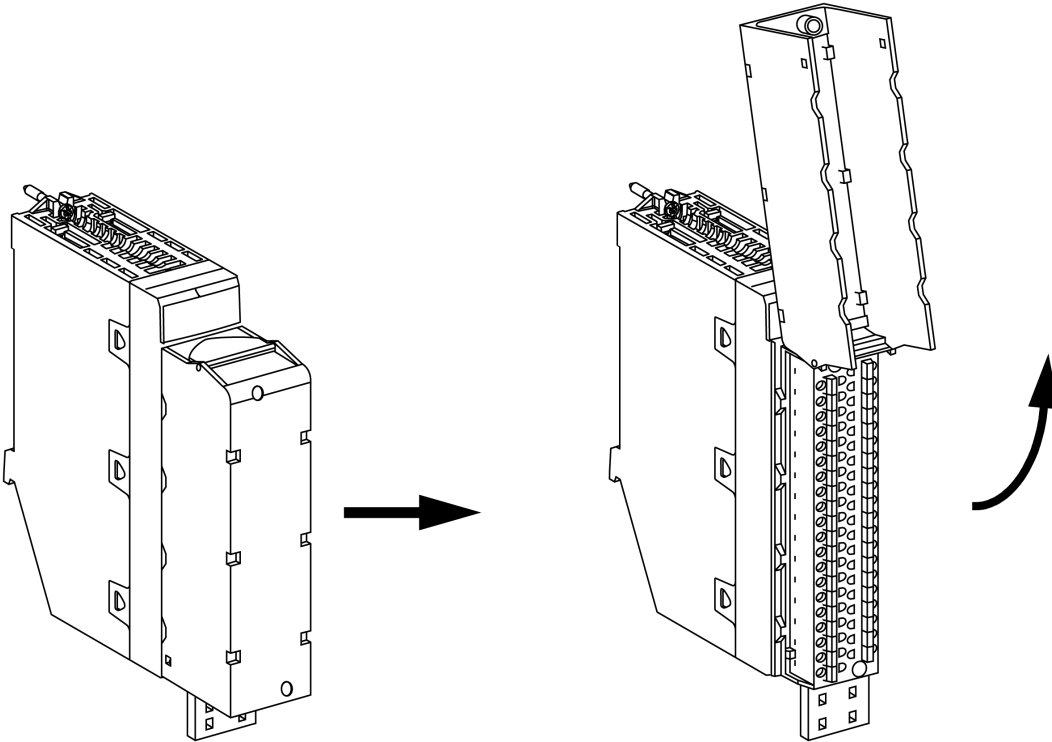
The following diagram shows the method for opening the terminal block cover so that it can be wired.



The connection cable is installed and held in place by cable clamps positioned below the terminal block.

NOTE: For installation where vibration can occur, do not let the cable loose from movement. Tighten cable to the bar of the shielding connection kit BMXXSP••00 or to rear mounting plate using cable clamp.

Labeling the Terminal Blocks

The labels for the terminal blocks are supplied with the module. They are to be inserted in the terminal block cover by the customer.

Each label has two sides:

- One side that is visible from the outside when the cover is closed. This side features the commercial product references, an abbreviated description of the module, as well as a blank section for customer labeling.
- One side that is visible from the inside when the cover is open. This side shows the terminal block connection diagram.

BMX FTW ••1 Cable

Introduction

20-pin connector modules are connected to sensors, pre-actuators or terminals using a cable designed to enable direct wire to wire transition of the module's inputs/outputs.

⚠ WARNING

UNEXPECTED EQUIPMENT OPERATION

Use only a connector that is designed for a specific module. Plugging the wrong connector can cause an unexpected behavior of the application.

Failure to follow these instructions can result in death, serious injury, or equipment damage.

BMX FTW ••1 Cable Description

The BMX FTW •01 cables are pre-assembled cord set, made up of:

- At one end, a compound-filled 20-pin BMX FTB 2020 terminal block from which extend 1 cable sheath containing 20 wires,
- At the other end, free wire ends differentiated by color code.

The figure below shows the BMX FTW •01 cables:

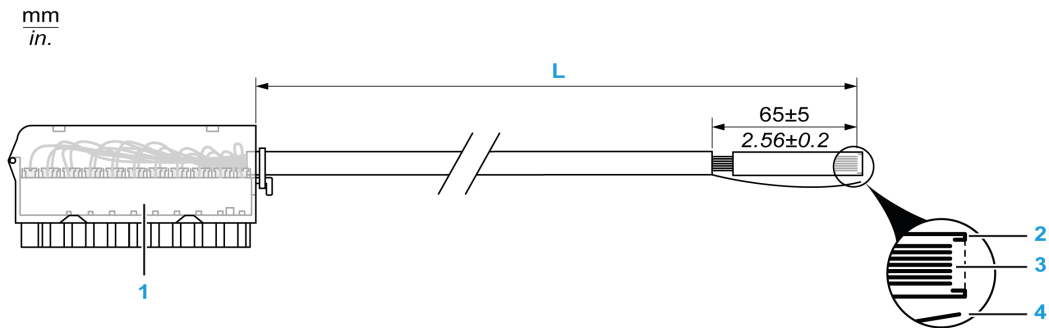

1 BMX FTB 2020 Terminal block

2 First of external sheath

3 Wires not stripped

4 Strand of nylon allowing the cable sheath to be stripped easily.

L Length according to the part number.

The connection cables come in three different lengths:

- 3 m (9.84 ft): BMX FTW 301
- 5 m (16.40 ft): BMX FTW 501
- 10 m (32.80 ft): BMX FTW 1001

Connection of BMX FTW ••1 Cables

The following diagram shows the connection of the BMX FTW ••1 cable:

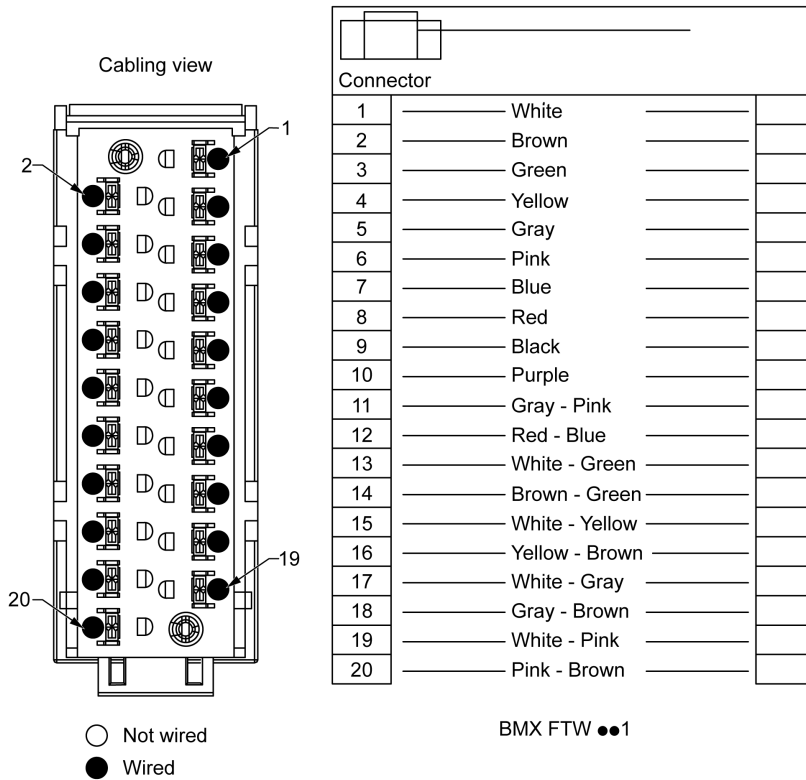

BMX FTW ••1 Cables Characteristics

This table presents the general characteristics:

Characteristics		Values
Cable	Sheath material	PVC
	LSZH status	No
Conductor description	Number of conductors	20
	Gauge	0.34 mm ² (22 AWG)
	Material	Tinned copper

Characteristics		Values
Environmental	Operating temperature	-25...70 °C (-13....158 °F)
Applicable standards		DIN47100

Cable Installation

DANGER

HAZARD OF ELECTRIC SHOCK

Turn off all power to sensor and pre-actuator devices before connection or disconnection of the terminal block.

Failure to follow these instructions will result in death or serious injury.

The following diagram shows the pre-assembled cable connected to the module:

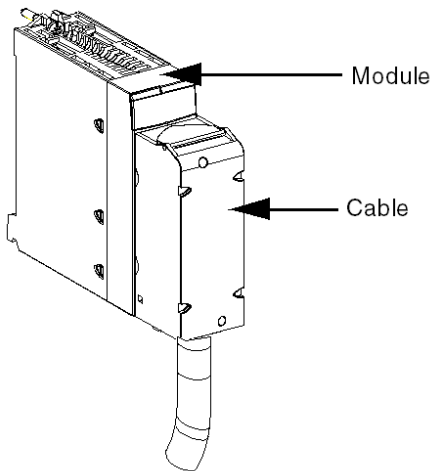

For more detailed information, refer to the topic *Fitting a 20-pin Terminal Block to a Module*, page 57.

BMX FTW ••5 Cable

Introduction

40-pin connector modules are connected to sensors, pre-actuators or terminals using a cable designed to enable direct wire to wire transition of the module's inputs/outputs.

▲ WARNING

UNEXPECTED EQUIPMENT OPERATION

Use only a connector that is designed for a specific module. Plugging the wrong connector can cause an unexpected behavior of the application.

Failure to follow these instructions can result in death, serious injury, or equipment damage.

BMX FTW ••5 Cable Description

The BMX FTW ••5 cables are pre-assembled cord set, made up of:

- At one end, a compound-filled 40-pin BMX FTB 4020 terminal block (non-gold plated spring terminal block) from which extend 1 cable sheath containing 40 wires,
- At the other end, free wire ends differentiated by color code.

NOTE: This preassembled cordset is only dedicated to standard module version.

▲ WARNING

UNINTENDED EQUIPMENT OPERATION

Do not use BMX FTW ••5 cable with hardened module.

Failure to follow these instructions can result in death, serious injury, or equipment damage.

The figure below shows the BMX FTW •05 cables:

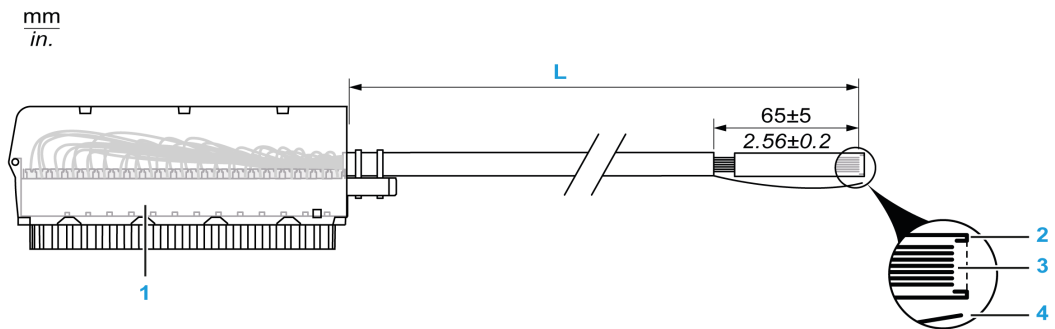

- 1** BMX FTB 4020 Terminal block
 - 2** First of external sheath
 - 3** Wires not stripped
 - 4** Strand of nylon allowing the cable sheath to be stripped easily.
- L** Length according to the part number.

The connection cables come in two different lengths:

- 3 m (9.84 ft): BMX FTW 305
- 5 m (16.40 ft): BMX FTW 505

Connection of BMX FTW ••5 Cables

The following diagram shows the connections and the color-coded according to DIN47100:

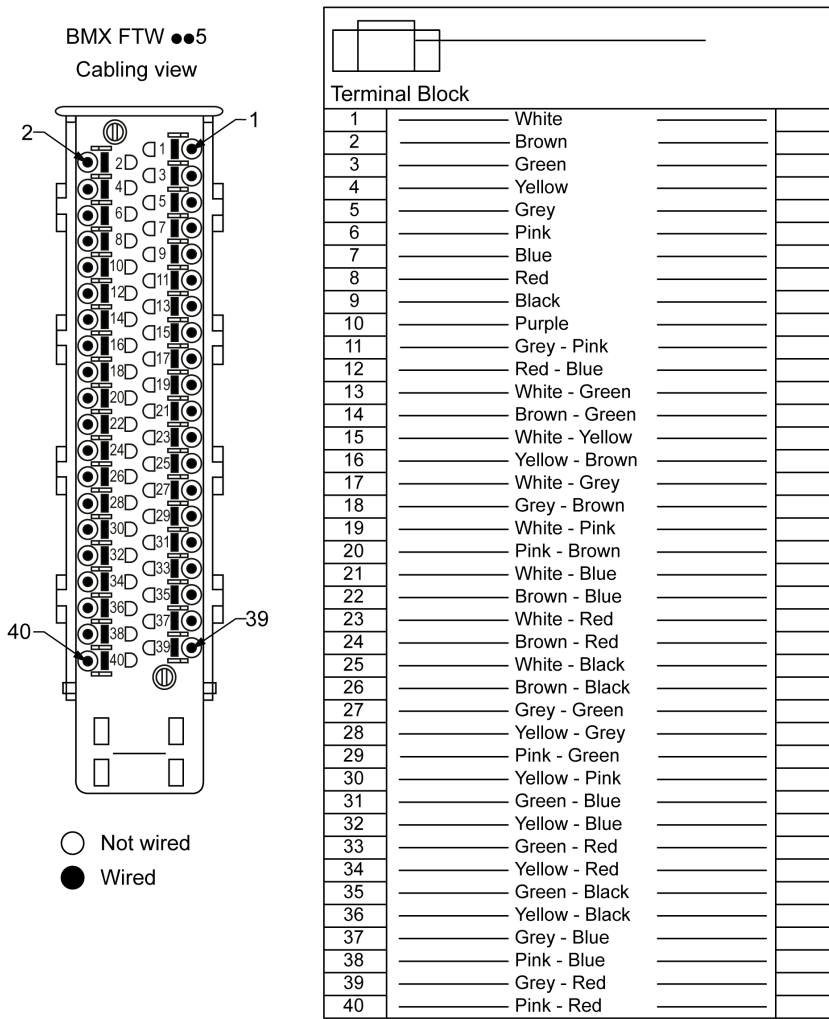

BMX FTW ••5 Cables Characteristics

This table presents the general characteristics:

Characteristics		Values
Cable	Sheath material	PVC

Characteristics		Values
	LSZH status	No
Application type	Maximum voltage	300 Vrms
Conductor description	Number of conductors	40
	Gauge	0.34 mm ² (22 AWG)
	Material	Tinned copper
	Maximum current	2 A below 30 °C (86 °F) 0.8 A below 70 °C (158 °F)
Electrical	Dielectric withstand	2500 V for 1 min.
Environmental	Operating temperature	-25...70 °C (-13....158 °F)
Applicable standards		DIN47100

BMX FTW ••5 Cables Installation

 **DANGER**

HAZARD OF ELECTRIC SHOCK

Turn off all power to sensor and pre-actuator devices before connection or disconnection of the terminal block.

Failure to follow these instructions will result in death or serious injury.

The following diagram shows the pre-assembled cable connected to the module:

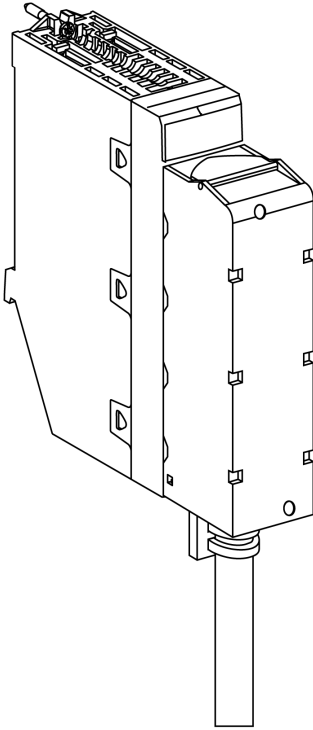

For more detailed information, refer to the topic [Fitting a 40-pin Terminal Block to a Module](#), page 62.

NOTE: For installation where vibration can occur, do not let the BMX FTW ••5 cable loose from movement. Tighten cable to the bar of the shielding connection kit BMXXSP••00 or to rear mounting plate using cable clamp.

Fitting a 20-pin Terminal Block to a Module

At a Glance

The modules with 20-pin terminal block connections require the terminal block to be connected to the module. These fitting operations (assembly and disassembly) are described below.

⚡ ⚠ DANGER

HAZARD OF ELECTRICAL SHOCK, EXPLOSION OR ARC FLASH

Terminal block must be connected or disconnected with sensor and pre-actuator voltage switched off.

Failure to follow these instructions will result in death or serious injury.

⚠ CAUTION

EQUIPMENT DAMAGE

Do not plug an AC terminal block into a DC module. This will cause damage to the module.

Failure to follow these instructions can result in injury or equipment damage.

Installing the Terminal Block

The following table shows the procedure for assembling the 20-pin terminal block onto a discrete input/output module.

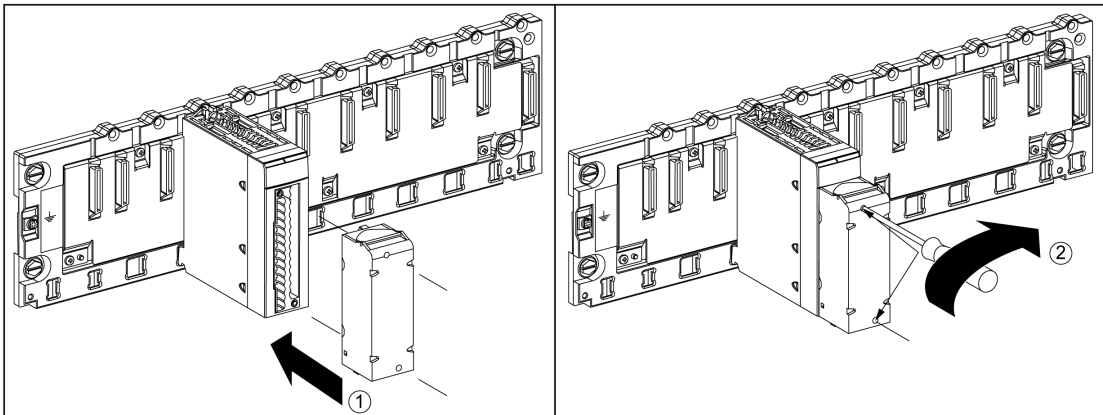

Assembly Procedure

Step	Action
1	Once the module is in place on the rack, install the terminal block by inserting the terminal block encoder (the rear lower part of the terminal) into the module's encoder (the front lower part of the module), as shown above. NOTE: The module connector have indicators which show the proper direction to use for terminal block installation.
2	Fix the terminal block to the module by tightening the 2 mounting screws located on the lower and upper parts of the terminal block. Tightening torque: 0.4 N•m (0.30 lbf-ft).

NOTE: If the screws are not tightened, there is a risk that the terminal block will not be properly fixed to the module.

Coding the 20-Pin Terminal Block

⚠ WARNING

UNEXPECTED BEHAVIOUR OF APPLICATION

- Code the terminal block as described below to prevent the terminal block from being mounted on another module.
- Plugging the wrong connector could cause unexpected behaviour of the application.

Failure to follow these instructions can result in death, serious injury, or equipment damage.

⚠ CAUTION

DESTRUCTION OF THE MODULE

- Code the terminal block as described below to prevent the terminal block from being mounted on another module.
- Plugging the wrong connector could cause the module to be destroyed.

Failure to follow these instructions can result in injury or equipment damage.

When a 20-pin terminal block is installed on a module dedicated to this type of terminal block, you can code the terminal block and the module using studs. The purpose of the studs is to prevent the terminal block from being mounted on another module. Incorrect insertion can then be avoided when replacing a module.

Coding is done by the user with the STB XMP 7800 guidance wheel's studs. You can only fill the 6 slots in the middle of the left side (as seen from the wiring side) of the terminal block, and can fill the module's 6 guidance slots on the left side.

To fit the terminal block to the module, a module slot with a stud must correspond to an empty slot in the terminal block, or a terminal block with a stud must correspond to an empty slot in the module. You can fill up to and including either of the 6 available slots as desired.

The diagram below shows a guidance wheel as well as the slots on the module used for coding the 20-pin terminal blocks.

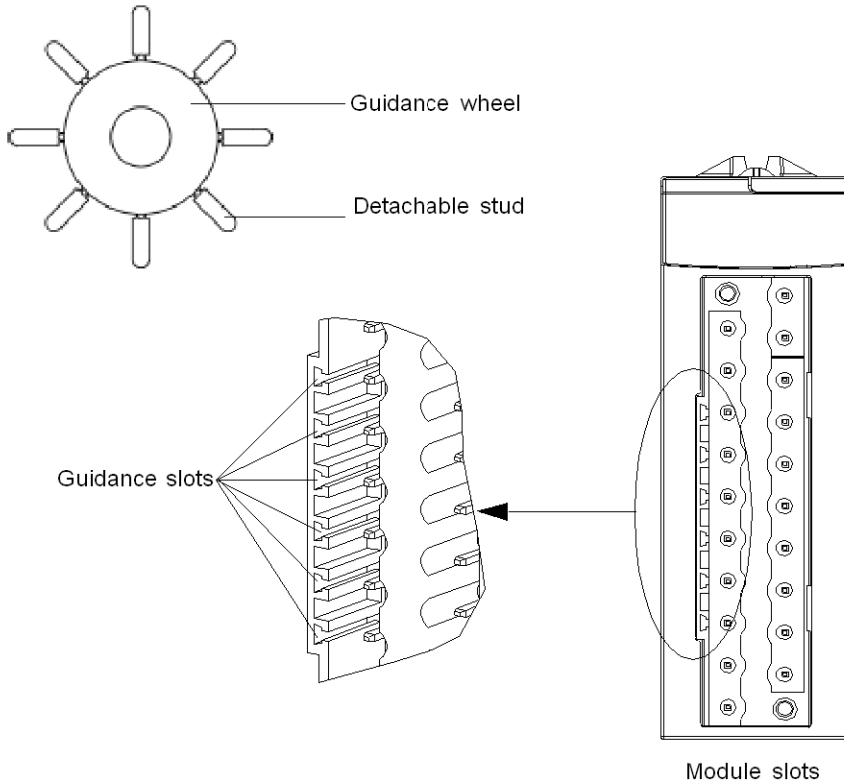

The diagram below shows an example of a coding configuration that makes it possible to fit the terminal block to the module.

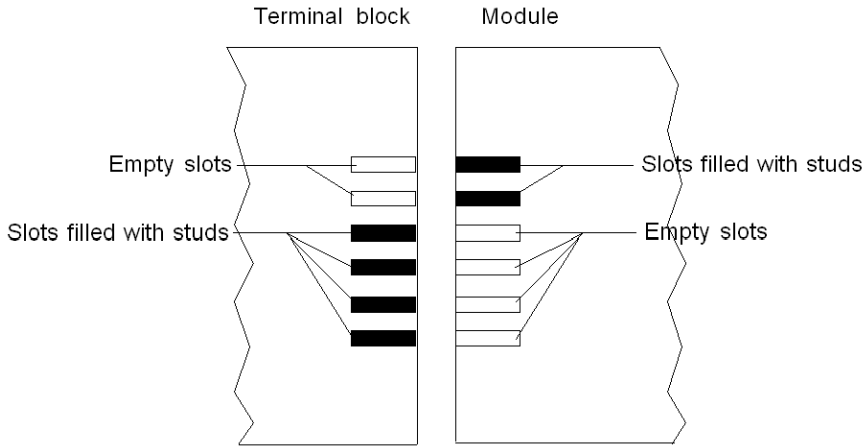

The diagram below shows an example of coding configuration with which it is not possible to fit the terminal block to the module.

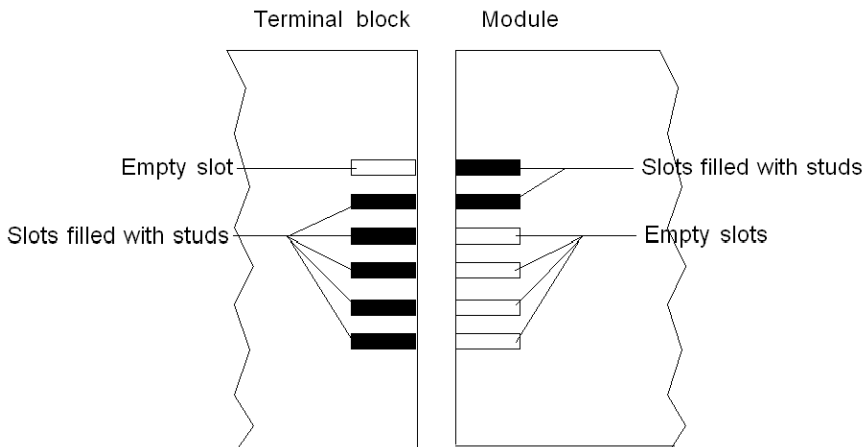

Fitting a 40-Pin Terminal Block to a Module

At a Glance

The modules with 40-pin terminal block connections require the terminal block to be connected to the module. These fitting operations (assembly and disassembly) are described below.

⚡ ⚠ DANGER

HAZARD OF ELECTRICAL SHOCK, EXPLOSION OR ARC FLASH

Terminal blocks must be connected or disconnected with sensor and pre-actuator voltage switched off.

Failure to follow these instructions will result in death or serious injury.

⚠ CAUTION

EQUIPMENT DAMAGE

Do not plug an AC terminal block into a DC module. This will cause damage to the module.

Failure to follow these instructions can result in injury or equipment damage.

Installing the 40-Pin Terminal Block

The following table shows the procedure for assembling the 40-pin terminal block onto a discrete input/output module.

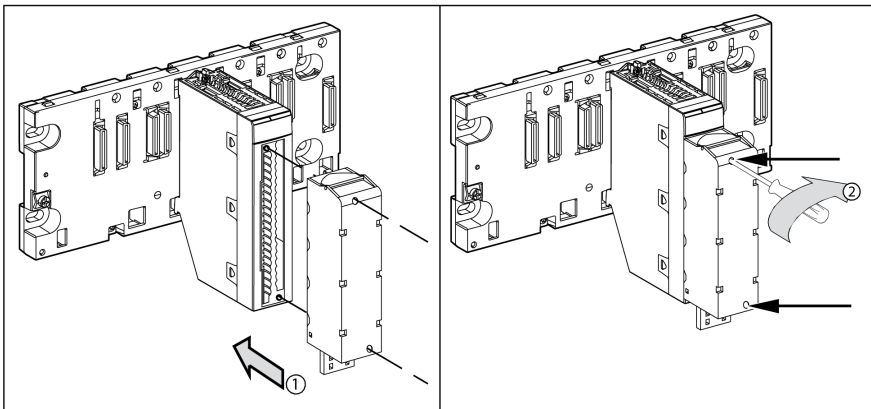

Assembly Procedure

Step	Action
1	<p>Once the module is in place on the rack, install the terminal block by inserting the terminal block encoder (the rear lower part of the terminal) into the module's encoder (the front lower part of the module), as shown above.</p> <p>NOTE: The module connector have indicators which show the proper direction to use for terminal block installation.</p>
2	<p>Fix the terminal block to the module by tightening the 2 mounting screws located on the lower and upper parts of the terminal block.</p> <p>Tightening torque: 0.4 N•m (0.30 lbf-ft).</p>

NOTE: If the screws are not tightened, there is a risk that the terminal block will not be properly fixed to the module.

Coding the 40-Pin Terminal Block

⚠ WARNING

UNEXPECTED BEHAVIOUR OF APPLICATION

- Code the terminal block as described below to prevent the terminal block from being mounted on another module.
- Plugging the wrong connector could cause unexpected behaviour of the application.

Failure to follow these instructions can result in death, serious injury, or equipment damage.

⚠ CAUTION

DESTRUCTION OF THE MODULE

- Code the terminal block as described below to prevent the terminal block from being mounted on another module.
- Plugging the wrong connector could cause the module to be destroyed.

Failure to follow these instructions can result in injury or equipment damage.

When a 40-pin terminal block is installed on a module dedicated to this type of terminal block, you can code the terminal block and the module using studs. The purpose of the studs is to prevent the terminal block from being mounted on another module. Incorrect insertion can then be avoided when replacing a module.

Coding is done by the user with the STB XMP 7800 guidance wheel's studs. You can only fill the 12 slots in the middle of the left side (as seen from the wiring side) of the terminal block, and can fill the module's 12 guidance slots on the left side.

To fit the terminal block to the module, a module slot with a stud must correspond to an empty slot in the terminal block, or a terminal block with a stud must correspond to an empty slot in the module. You can fill up to and including either of the 12 available slots as desired.

The diagram below shows a guidance wheel as well as the slots on the module used for coding the 40-pin terminal blocks.

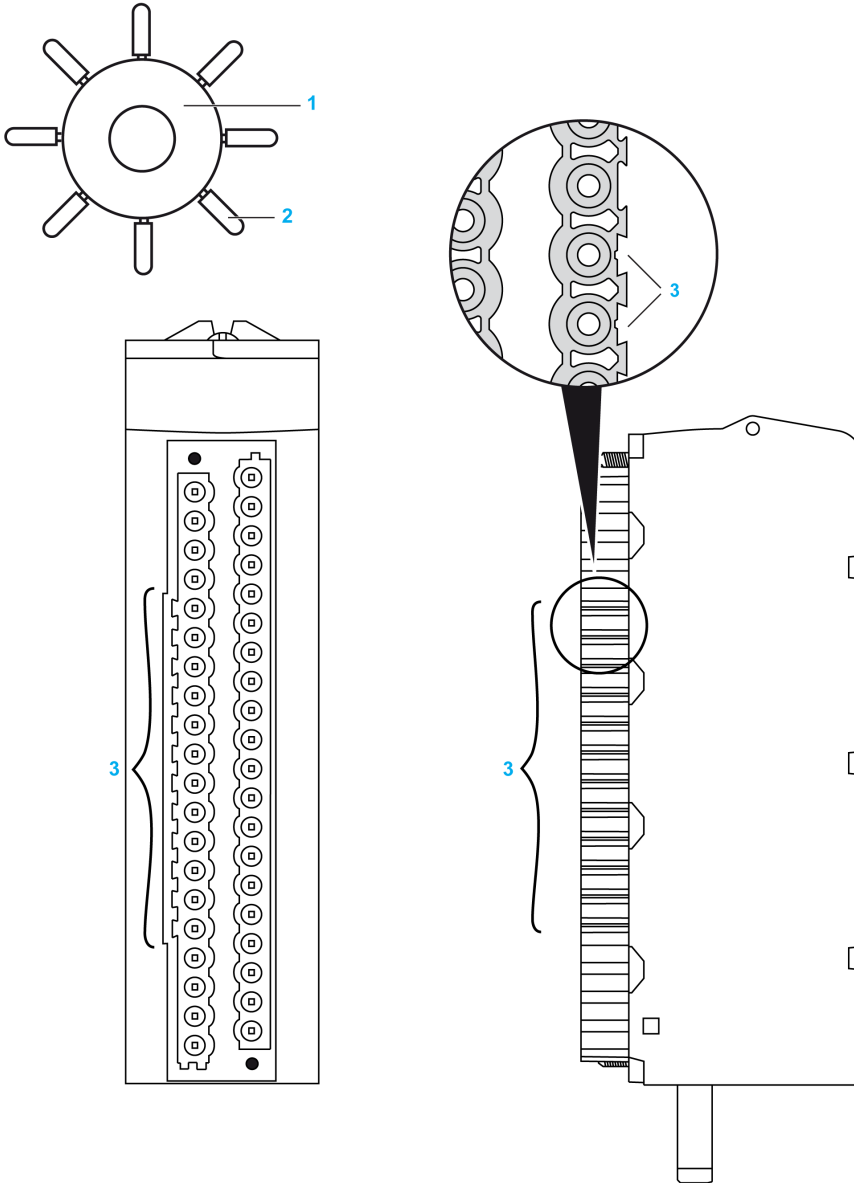

1 Guidance wheel

2 Detachable stud

3 Guidance slots

The diagram below shows an example of a coding configuration that makes it possible to fit the terminal block to the module.



The diagram below shows an example of coding configuration with which it is not possible to fit the terminal block to the module.



Fitting a 40-pin FCN Type Connector to a Module

At a Glance

The modules with 40-pin FCN type connections require the latter to be connected to the module. These fitting operations (assembly and disassembly) are described below.

⚡ ⚠ DANGER

ELECTRICAL SHOCK

FCN type connector must be connected or disconnected with sensor and pre-actuator voltage switched off.

Failure to follow these instructions will result in death or serious injury.

⚠ CAUTION

EQUIPMENT DAMAGE

Do not plug an AC connector on a DC module. This would cause equipment damage.

Failure to follow these instructions can result in injury or equipment damage.

Installing the Connector

The following table shows the procedure for assembling the connector onto modules:

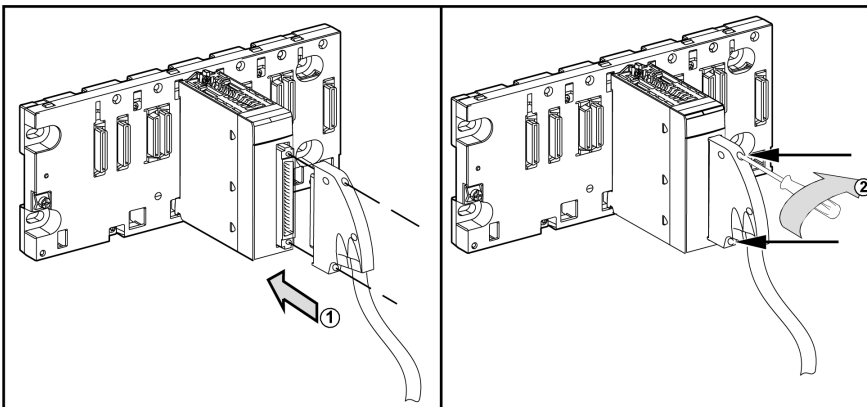

Assembly procedure:

Step	Action
1	Once the module is in place on the rack, insert the FCN connector of the cable into the module's connector, as shown above.
2	Fix the connector to the module by tightening the 2 mounting screws located on the lower and upper parts of the terminal block. Tightening torque: 0.4 N•m (0.30 lbf-ft).

NOTE: If the screws are not tightened, there is a risk that the terminal block will not be properly fixed to the module.

Presentation for Choosing Power Supplies for Sensors and Pre-Actuators

At a Glance

The different choices of power supply for sensors and pre-actuators linked to discrete input/output modules require certain usage precautions to be observed.

External Direct Current Power Supplies

⚠ WARNING

UNEXPECTED EQUIPMENT OPERATION

When using an external 24 VDC direct current power supply, use either:
regulated power supplies or

non-regulated power supplies with:

- filtering of 1000 $\mu\text{F}/\text{A}$ with full-wave single phase rectification and 500 $\mu\text{F}/\text{A}$ with tri-phase rectification
- a 5% maximum peak to peak ripple rate
- a maximum voltage variation of: -20% to +25% of the nominal voltage (including ripple)

Rectified power supplies with no filtering are prohibited.

Failure to follow these instructions can result in death, serious injury, or equipment damage.

Ni-Cad Battery Power Supplies

Ni-Cad battery power supplies can be used to power sensors and pre-actuators and all associated inputs/outputs that have a normal operating voltage of 30 VDC maximum.

While being charged, this type of battery can reach, for a duration of one hour, a voltage of 34 VDC. For this reason, all input/output modules with an operating voltage of 24 VDC can withstand this voltage (34 VDC) for up to one hour every 24 hours. This type of operation entails the following restrictions:

- at 34 VDC, the maximum current withstood by the outputs must under no circumstances exceed the maximum current defined for a voltage of 30 VDC
- temperature downgrading imposes the following restrictions:
 - 80% of inputs/outputs at 1 up to 30°C
 - 50% of inputs/outputs at 1 up to 60°C

CAUTION

OVERHEATING HAZARD

Take into account the temperature derating of the discrete I/O modules at the installation to prevent the device from overheating and/or deteriorating.

Failure to follow these instructions can result in injury or equipment damage.

External AC Current Power Supplies

All BMXDAI****, BMXDAO****, BMXDRA****, and BMXDRC**** modules are designed for a use in zone A and B defined in the PLC standard IEC 61131-2 and the generic EMC standard IEC 61000-6-2 without any specific protection against surges.

The following figure shows the zones defined in the PLC standard IEC 61131-2:

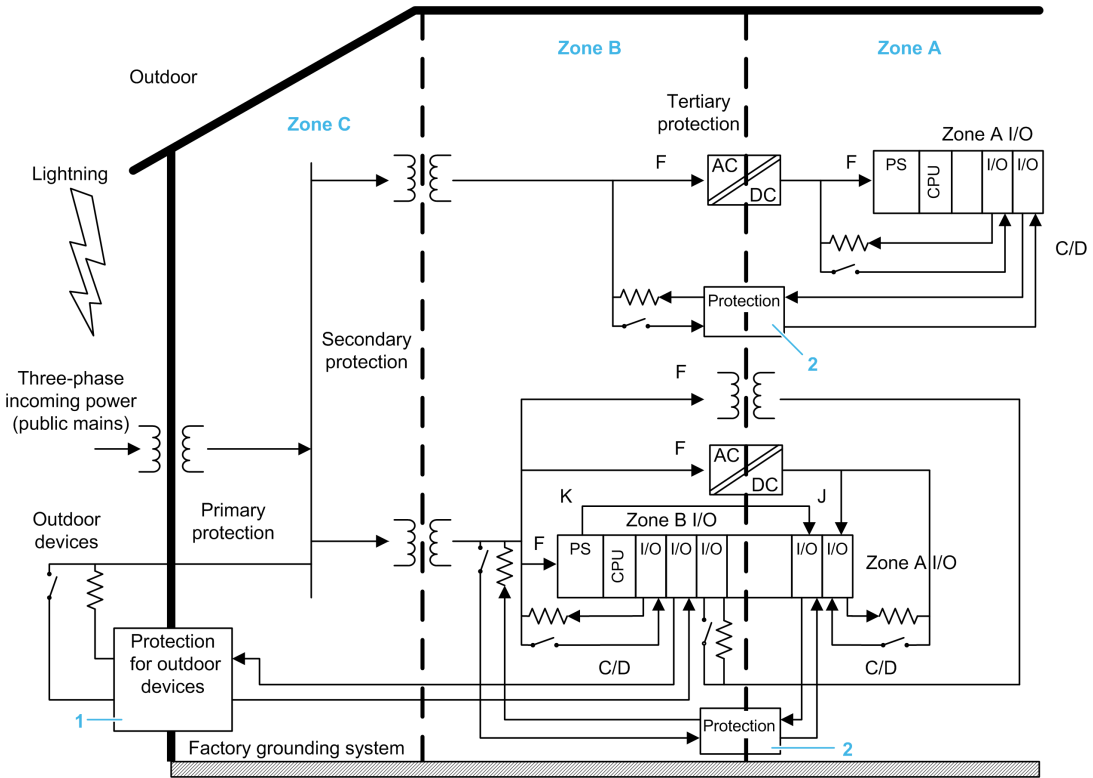

Zone A Local power distribution

Zone B Dedicated power distribution

Zone C Factory mains

1 Protection network should be appropriate to reduce Severity Levels from those of outdoor to Zone B.

2 Protection network should be appropriate to reduce Severity Levels from those of Zone A to Zone B

It is also suited to be installed in a power generation station/substation according to the generic standard IEC 61000-6-5 for interfaces type 1 and 2, without any specific protection against surges.

The following figure shows the interface types defined in the generic standard IEC 61000-6-5:

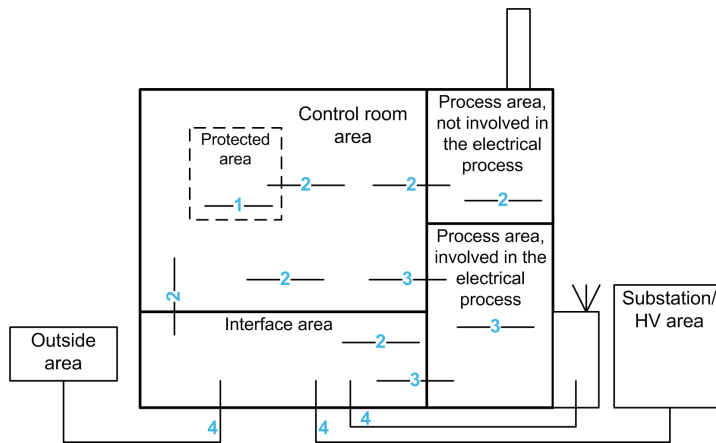

- 1 Inside protected area
- 2 Inside interface and/or control room and/or process area not involved in the electrical process
- 3 Inside or from process area involved in the electrical process
- 4 Connections from outside (HV area and external telecommunication)

Protection Against Surges of AC Power Lines for More Severe Environments

The design of these modules are suited to ensure an immunity level for surges of 2 kV Line to ground and 1 kV line to line and do not require any external protection on AC line branch.

If it is intended to install the PLC and its AC I/Os in a IEC 61131-2 zone C or to a IEC 61000-6-5 type 3 or type 4 interface: primary protection provided only and severe interference coupling, it is the responsibility of the system integrator or the customer to take care of the system and protect it in the right manner.

It is possible, providing mitigation measures, to install the PLC and the IO module in a such environment.

All the installation requirements are detailed in the chapter J - Overvoltage protection of the Schneider Electrical Installation Guide. This documentation is available for download on www.se.com.

Adding a type 2/class II surge protection device (SPD), for example an iQuick PRD20r modular surge arrester with voltage protection level (U_p) ≤ 1.5 kV, will allow to withstand surges of 4 kV Line to ground and 2 kV line to line.

Wiring Precautions

At a Glance

Discrete inputs/outputs feature protective measures which ensure a high resistance to industrial environmental conditions. Nevertheless, the rules described below must be followed.

External Power Supplies for Sensors and Pre-Actuators

Use quick-blow fuses to protect external sensor and pre-actuator power supplies associated with discrete input/output modules against short-circuits and overloads.

For 40-pin connector discrete input/output modules, link the sensor/pre-actuator power supply to each connector, except in the event where the corresponding channels are not in use and are not assigned to any task.

DANGER

IMPROPER GROUNDING HAZARD

Install the 24V supply according to applicable codes. The 0V terminals of the 24V power supplies must be connected to metallic ground and safety ground as close as possible to the supply. This is to ensure personnel safety in the event of a power phase coming into contact with the 24V supply.

Failure to follow these instructions will result in death or serious injury.

NOTE: If an input/output module is present on the PLC, connect the sensor and pre-actuator power supply to the power supply of the module otherwise, an external power supply error occurs causing the input/output LED to flash.

Inputs

Recommendations for use concerning the inputs of discrete modules are as follows:

- **for 24 VDC inputs and line coupling with an alternating current network:**

⚠ WARNING

UNEXPECTED EQUIPMENT OPERATION

- Avoid excessive coupling between AC cables and cables relaying signals intended for direct current inputs.
- Follow the cable routing rules.

Failure to follow these instructions can result in death, serious injury, or equipment damage.

This case (excessive coupling) is illustrated in the following circuit diagram.

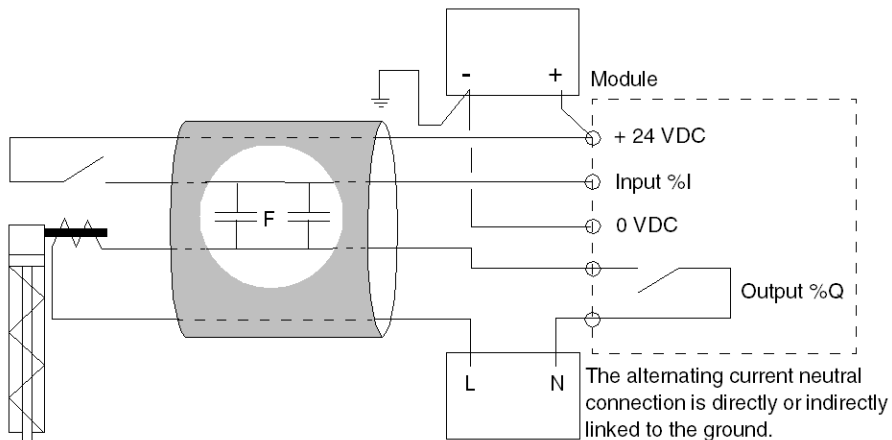

When the input contact is open, the alternating currents may induce a current in the input which might cause it to be set to 1.

For a 240 VAC/50 Hz line coupling, do not exceed the line capacitance values given in the summary table at the end of this section. For a coupling with a different voltage, use the following formula:

$$\text{Capacitance tolerated} = (\text{Capacity at 240VAC} \times 240) / (\text{Line voltage})$$

- **for 24 to 240 VAC inputs and line coupling:**

When the line that controls the input is open, the current passes according to the coupling capacitance of the cable (see circuit diagram below).

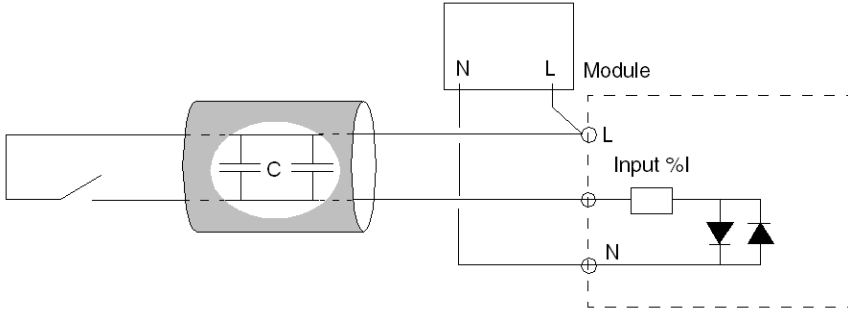

Do not exceed the line capacitance values given in the summary table below.
 The following summary table shows the acceptable line capacitance values.

Module	Maximum coupling capacitance
24 to 125 VDC inputs	
BMX DDI 1602	45 nF ⁽¹⁾
BMX DDI 1603	
BMX DDI 1604T	
BMX DDM 16022	
BMX DDM 16025	
BMX DDI 3202 K	25 nF ⁽¹⁾
BMX DDI 6402 K	
BMX DDM 3202 K	
24 to 140 VAC inputs	
BMX DAI 0805	50 nF
BMX DAI 1615	
BMX DAI 1602	50 nF
BMX DAI 1603	60 nF

Module	Maximum coupling capacitance
BMX DAI 0814	70 nF
BMX DAI 1614	
BMX DAI 1604	
(1) max. admissible coupling capacitance with a 240 VAC / 50 Hz linemax. admissible coupling capacitance with a 240 VAC / 50 Hz line	

Example: A standard cable of 1 m in length has a coupling capacity that falls within 100 and 150 pF.

Outputs

For the outputs of discrete I/O modules, follow the recommendations described here.

⚠ WARNING
<p>UNEXPECTED EQUIPMENT OPERATION</p> <p>Use wires of a sufficient diameter to avoid drops in voltage, overheating, and unexpected equipment operation.</p> <p>Failure to follow these instructions can result in death, serious injury, or equipment damage.</p>

Cable Routing

⚠ WARNING
<p>UNEXPECTED EQUIPMENT OPERATION</p> <p>Observe the precautions below for the wiring system.</p> <p>Failure to follow these instructions can result in death, serious injury, or equipment damage.</p>

Precautions for use to be taken concerning the wiring system are as follows:

- in order to reduce the number of alternating couplings, separate the power circuit cables (power supplies, power switches, etc.) from input cables (sensors) and output cables (pre-actuators) both inside and outside the equipment
- outside the equipment, place the cables leading to inputs/outputs in covers that make them easily distinguishable from those containing wires relaying high energy levels.

Place them in separate metal cableways which are grounded. Route these various cables at least 100 mm (4 in.) apart

How to Connect Discrete Input/Output Modules: Connecting 40-Pin Connector Modules

Introduction

40-pin connector modules are connected to sensors, pre-actuators, or terminals using a cable designed to enable trouble-free direct wire to wire transition of the module's inputs/ outputs.

⚡ ⚠ DANGER

HAZARD OF ELECTRIC SHOCK, ARC FLASH OR EXPLOSION

40-pin connectors must be connected or disconnected with sensor and pre-actuator voltage switched off.

Failure to follow these instructions will result in death or serious injury.

The following diagram shows the connection of the cable to the module.

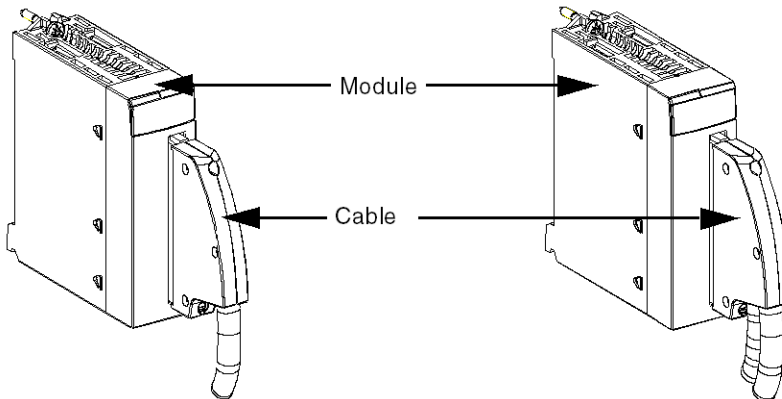

⚠ WARNING

UNEXPECTED EQUIPMENT OPERATION

During the installation process, ensure that the connectors are identified with the corresponding modules so that incorrect connection cannot occur. Plugging the wrong connector into a module will result in unexpected equipment operation.

Failure to follow these instructions can result in death, serious injury, or equipment damage.

BMX FCW ••• Connection Cables

They are made up of:

- at one end, a compound-filled 40-pin connector from which extend 1 or 2 cable sheaths, each containing 20 wires with a cross-sectional area of 0.34 mm² (AWG 22)

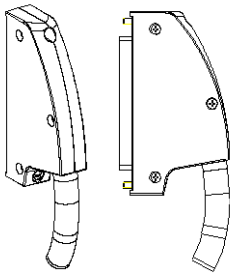

BMX FCW ••1

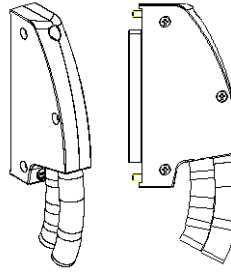

BMX FCW ••3

- at the other end, free wire ends color coded

The cables with 1 cable sheath containing 20 wires designed to connect the 40-pin connectors to the sensors or pre-actuators come in 3 different lengths:

- 3 meters: BMX FCW 301
- 5 meters: BMX FCW 501
- 10 meters: BMX FCW 1001

The figure below shows the BMX FCW ••1 cables.

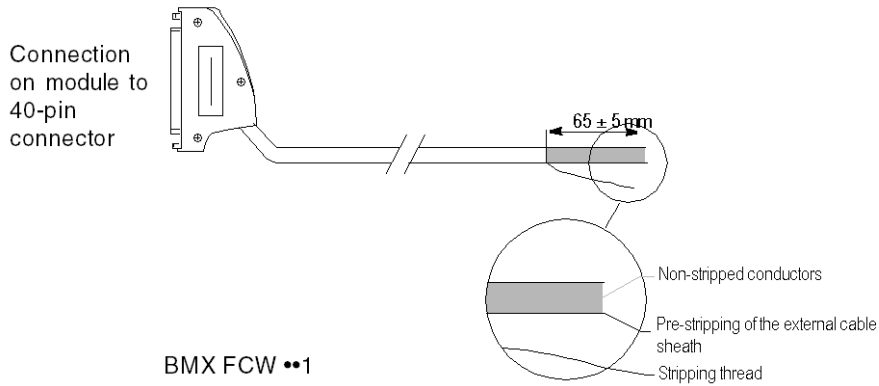

The cables with 2 cable sheaths containing 20 wires designed to connect the 40-pin connectors to the sensors or pre-actuators come in 3 different lengths:

- 3 meters: BMX FCW 303
- 5 meters: BMX FCW 503
- 10 meters: BMX FCW 1003

The figure below shows the BMX FCW ••3 cables.

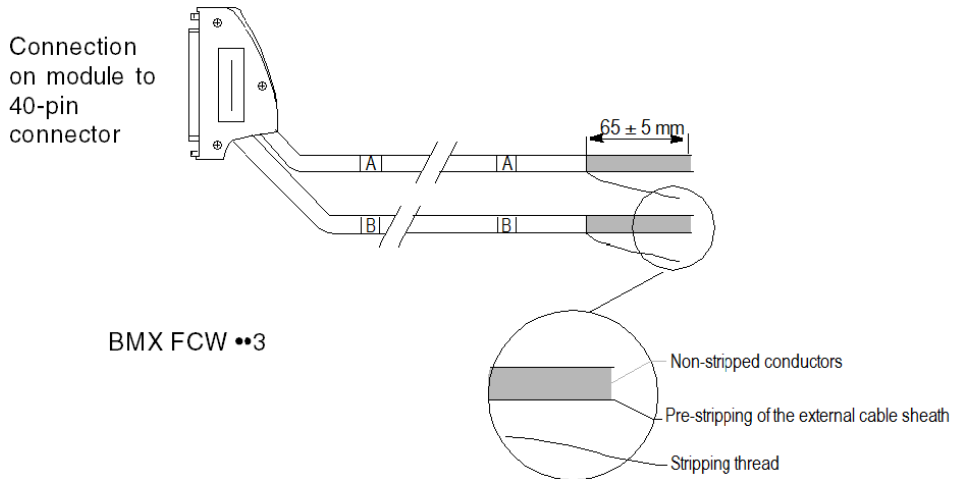

NOTE: A strand of nylon incorporated in the cable allows the cable sheath to be stripped with ease.

NOTE: The maximum torque for tightening BMX FCW ••• cable connection screws is 0.8 N•m (0.59 lb-ft).

▲ WARNING

UNEXPECTED EQUIPMENT OPERATION

Do not exceed the maximum tightening torque. Excessive torque may result in wire breakage, resulting in poor or intermittent connection.

Failure to follow these instructions can result in death, serious injury, or equipment damage.

Connection of BMX FCW ... Cables

The diagram below shows the connection of BMX FCW ••1 cables:

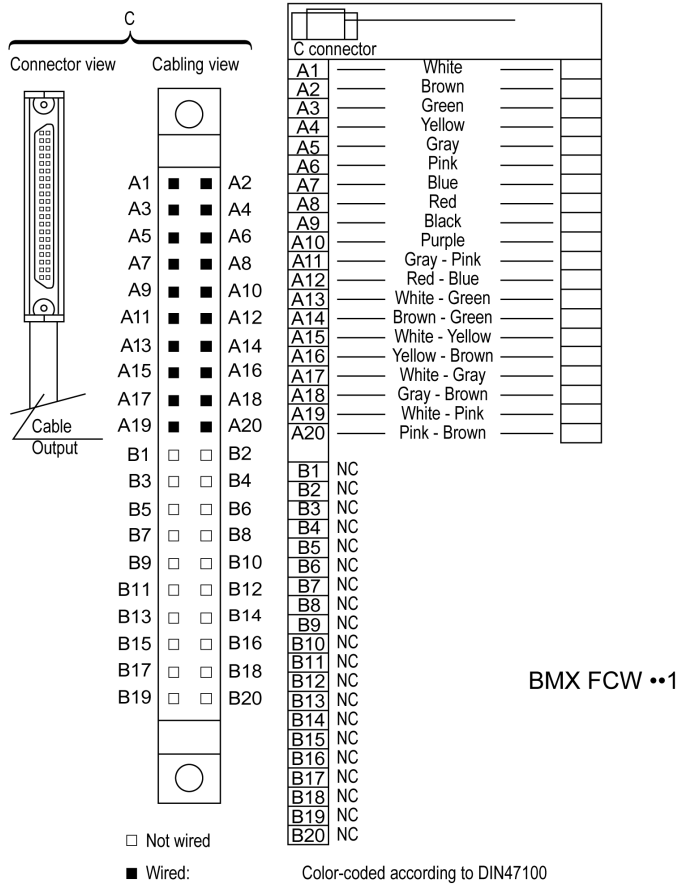

The diagram below shows the connection of BMX FCW ••3 cables:

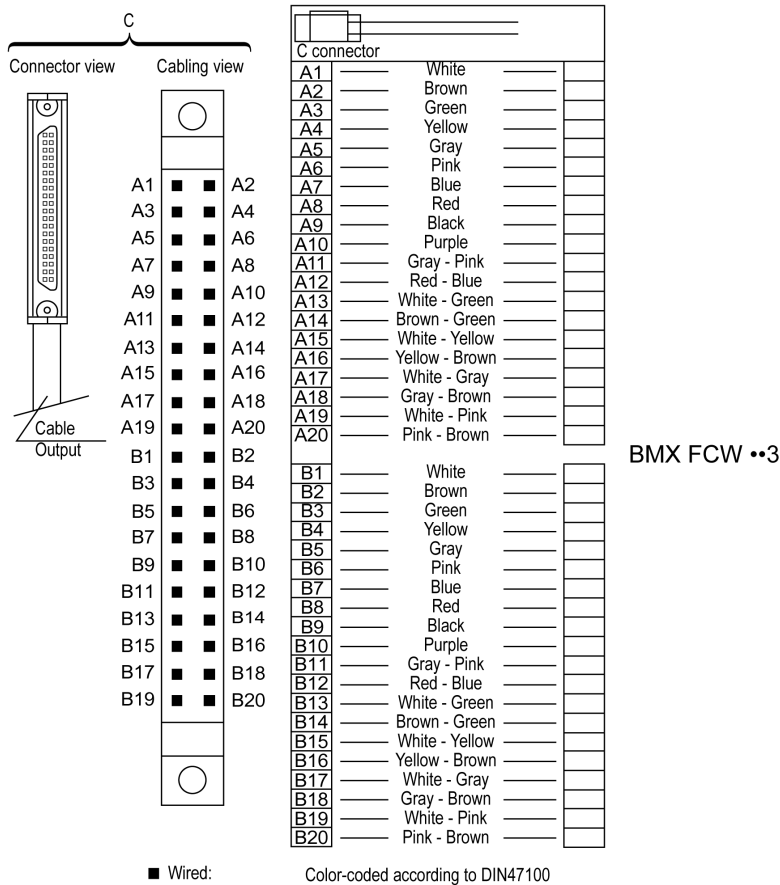

BMX FCW ••• Cables Characteristics

This table presents the general characteristics:

Characteristics		Values
Cable	Sheath material	PVC
	LSZH status	No
Conductor description	Number of conductors	<ul style="list-style-type: none"> • 20 for BMX FCW ••1 • 40 for BMX FCW ••3
	Gauge	0.34 mm ² (22 AWG)
	Material	Tinned copper

Characteristics		Values
Environmental	Operating temperature	-25...70 °C (-13....158 °F)
Applicable standards		DIN47100

How to Connect Discrete Input/Output Modules: Connecting 40-Pin Connector Modules to TELEFAST Interfaces

At a Glance

The inputs/outputs of discrete 40-pin connector modules are connected to TELEFAST quick-wiring connection and adaptation interfaces using specific cables for 40-pin to HE10 connectors.

Illustration

The drawing below shows the connection of a discrete 40-pin connector module to a TELEFAST interface.

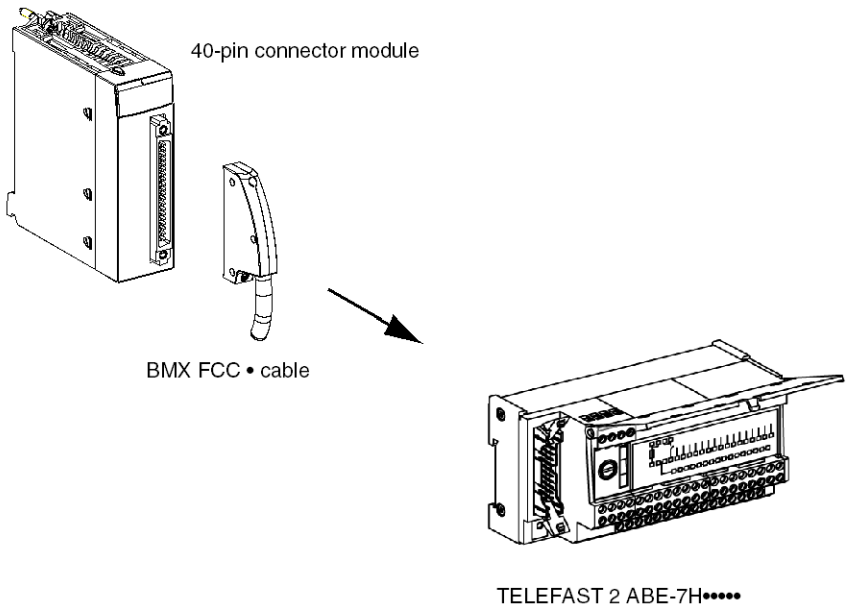

BMX FCC •• Connection Cables

The cables designed for connecting 40-pin connectors to 1xHE10 come in 6 different lengths:

- 0.5 meters, 20 wires: BMX FCC 051
- 1 meter, 20 wires: BMX FCC 101
- 2 meters, 20 wires: BMX FCC 201
- 3 meters, 20 wires: BMX FCC 301
- 5 meters, 20 wires: BMX FCC 501
- 10 meters, 20 wires: BMX FCC 1001

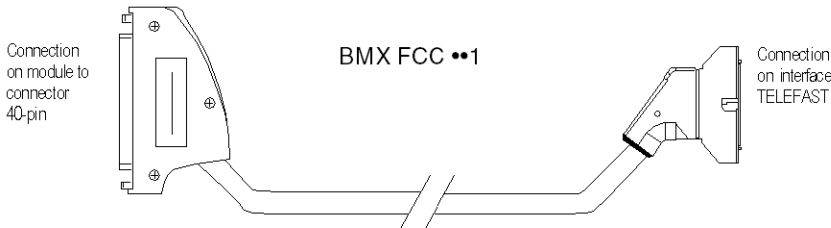

The cables designed for connecting 40-pin connectors to 2xHE10 come in 6 different lengths:

- 0.5 meters, 20 wires: BMX FCC 053
- 1 meter, 20 wires: BMX FCC 103
- 2 meters, 20 wires: BMX FCC 203
- 3 meters, 20 wires: BMX FCC 303
- 5 meters, 20 wires: BMX FCC 503
- 10 meters, 20 wires: BMX FCC 1003

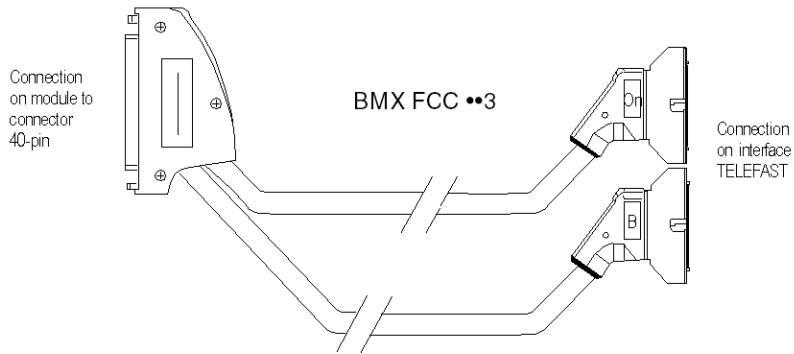

Connection of BMX FCC ••• Cables

The diagram below shows the connection of BMX FCC ••1 cables.

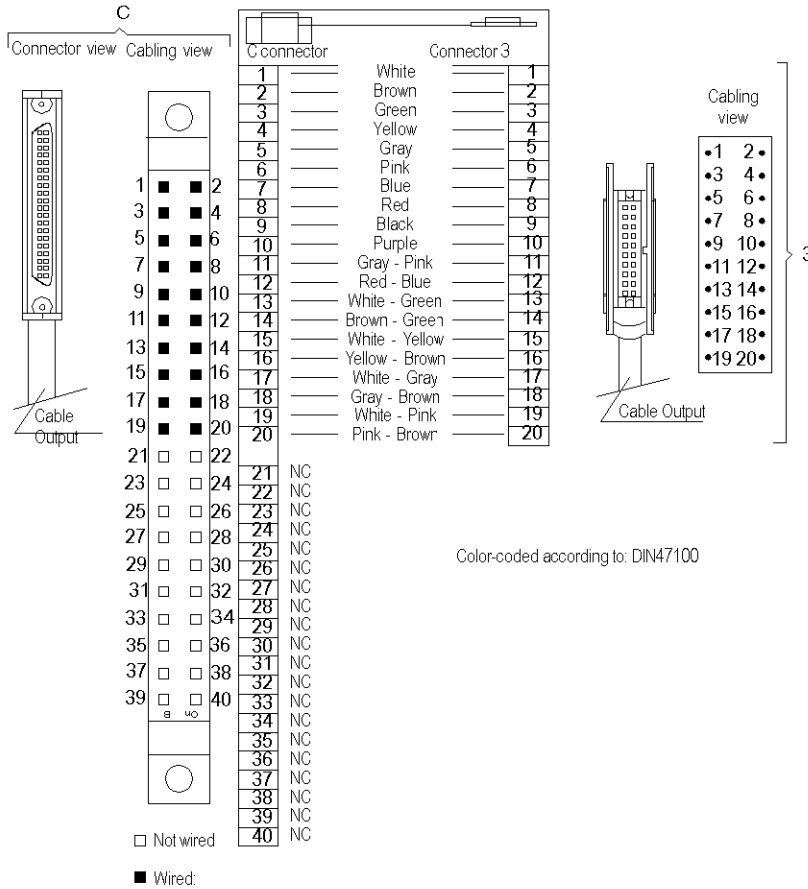

The diagram below shows the connection of BMX FCC ••3 cables.

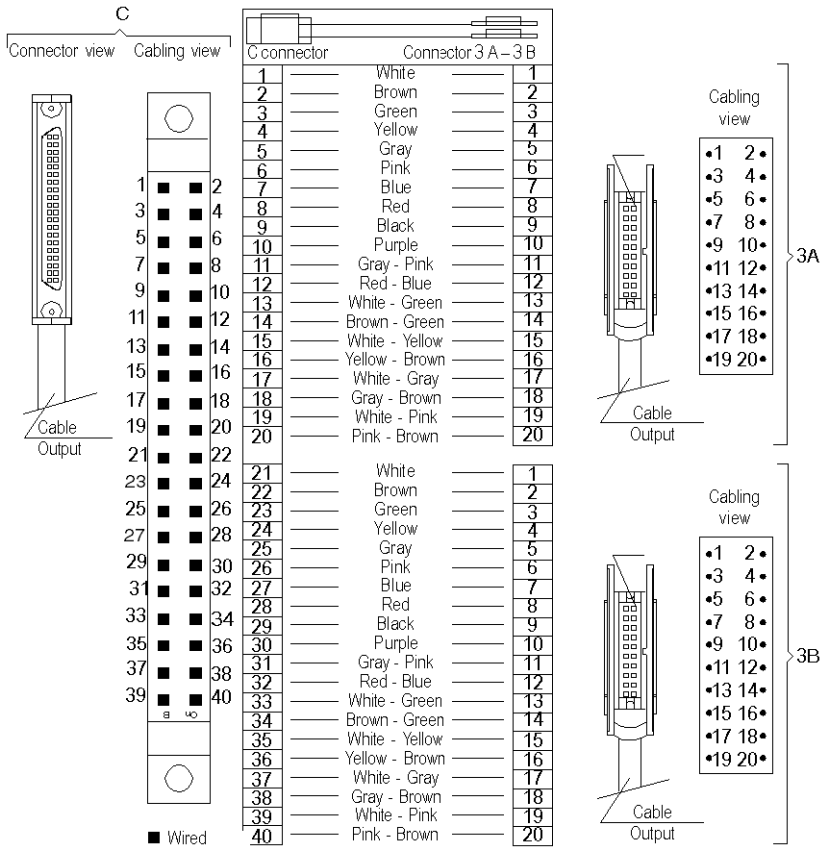

NOTE: The maximum torque for tightening BMX FCC ••• cable connection screws is 0,5 N•m (0.37 lb-ft).

⚠ WARNING

UNEXPECTED EQUIPMENT OPERATION

Do not exceed the maximum tightening torque. Excessive torque may result in wire breakage, resulting in poor or intermittent connection.

Failure to follow these instructions can result in death, serious injury, or equipment damage.

BMX FCC •• Cables Characteristics

This table presents the general characteristics:

Characteristics		Values
Cable	Sheath material	PVC
	LSZH status	No
Conductor description	Number of conductors	<ul style="list-style-type: none"> • 20 for BMX FCC ••1 • 40 for BMX FCC ••3
	Gauge	0.34 mm ² (22 AWG)
	Material	Tinned copper
Environmental	Operating temperature	-25...70 °C (-13....158 °F)
Applicable standards		DIN47100

Sensor/Input Compatibility and Pre-actuator/Output Compatibility

At a Glance

The compatibility between sensors and discrete module inputs depends on the type of sensor used.

Similarly, the compatibility between pre-actuators and discrete module outputs depends on the type of pre-actuator used.

Sensor/Input Compatibility

The following table presents the compatibility between 3-wire sensors and 24 VDC and 48 VDC inputs.

<p>3-wire sensors and IEC 61131-2 compliant type 3 positive logic (sink) inputs: all 3-wire PNP inductive or capacitive proximity sensors and photo-electric detectors which have an operating voltage of 24 VDC and 48 VDC are compatible with all positive logic inputs.</p>	
<p>3-wire sensors and negative logic (source) inputs: all 3-wire NPN inductive or capacitive proximity sensors and photo-electric detectors which have an operating voltage of 24 VDC and 48 VDC are compatible with all negative logic inputs.</p>	

The following table presents the compatibility between 2-wire sensors and 24 VDC and 48 VDC inputs.

<p>2-wire sensors and IEC 61131-2 compliant type 1 positive logic (sink) inputs: all proximity sensors or other 2-wire sensors with an operating voltage of 24 VDC and 48 VDC and with the characteristics described in the next table are compatible with all positive logic 24 VDC inputs.</p>	
<p>2-wire sensors and negative logic (source) inputs: all proximity sensors or other 2-wire sensors with an operating voltage of 24 VDC are compatible with all negative logic 24 VDC inputs.</p>	

Compatibility between 2-wire sensors and 24/48 VAC and 120 VAC inputs:

All IEC 60947-5-2 compliant 2-wire AC proximity sensors able to withstand 100...120 VAC are compatible with all IEC 61131-2 type 1 and type 3 compliant 110...20 VAC inputs.

The following tables provide a summary of compatibility between sensors and discrete input/output module inputs.

Types of proximity sensor	Types of input			
	24 VDC Positive logic	48 VDC Type 1 Positive logic	24 VDC Type 3 Positive logic	24/48 VDC Negative logic
All PNP-type 3-wire (DC) proximity sensors	X	X	X	-
All NPN-type 3-wire (DC) proximity sensors	-	-	-	X
Telemecanique or other brand 2-wire (DC) proximity sensors with the following characteristics: <ul style="list-style-type: none"> • Voltage drop in closed state $\leq 7\text{ V}$ • Minimum switched current $\leq 2.5\text{ mA}$ • Residual current in open state $\leq 1.5\text{ mA}$ 	-	X	X	-
Telemecanique or other brand 2-wire (DC) proximity sensors with the following characteristics: <ul style="list-style-type: none"> • Voltage drop in closed state $\leq 4\text{ V}$ • Minimum switched current $\leq 1\text{ mA}$ • Residual current in open state $\leq 0.5\text{ mA}$ 	X	X	X	-
X compatible - not compatible DC DC voltage operation				

Types of proximity sensor	Types of input		
	24 VAC Type 1	48 VAC Type 3	100-120 VAC Type 3
2-wire (AC/DC) proximity sensor (see note)	X	X	X
2-wire (AC) proximity sensor	X	X	X
X compatible AC AC voltage operation AC/DC AC or DC voltage operation NOTE: 24 VDC inputs can be used in positive (sink) or negative (source) logic but are not IEC compliant.			

Compatibility of Pre-Actuators with Outputs

Compatibility of DC Pre-actuators with Outputs:

Comply with the output's maximum current and maximum switching frequency as specified in the module characteristics.

NOTE: Where low consumption pre-actuators are used, special attention must be paid to the leakage current of the idle output, to ensure that the maximum current is correctly calculated:

$$I_{\max} = I_{\text{nominal}} + I_{\text{leakage}}$$

Given that:

I_{nominal} = Current required to operate by the pre-actuator

I_{leakage} = Maximum leakage current in idle output state

Compatibility of Tungsten Filament Lamps and Static Outputs (Static Current):

For outputs with protection against short circuits, the maximum power of the tungsten filament lamps specified in the module characteristics must comply. If not, the lamp's pick-up current might cause a tripped output at the time of power-up.

Compatibility of AC Pre-actuators and Relay Outputs:

Inductive AC pre-actuators have a pick-up current of up to 10 times their holding current for a duration of $2/F$ seconds (F = alternating current frequency). Relay outputs are therefore set to withstand these conditions (AC14 and AC15). The table of characteristics for relay outputs gives the maximum authorized running power (in AV) according to the number of operations.

CAUTION

SHORTENED RELAY LIFE

Ensure that currents switched by the relay outputs do not exceed the relay ratings. Excessive currents will shorten relay life.

Failure to follow these instructions can result in injury or equipment damage.

Discrete Input/Output Module Diagnostic Processing

What's in This Chapter

General Protective Measures.....	91
Module and Channel Status Display.....	92
Diagnostics	96
Checking the Connection.....	99

Subject of this Section

This section explains the processing of hardware detected faults related to discrete input/output modules.

General Protective Measures

At a Glance

Some general protective measures are integrated into the channels of discrete input/output direct current modules.

DC Outputs

Every static output (except where specifically labeled "Non-Protected"), features a protective device which allows the following to be detected when an output is active:

- **An overload or short circuit.** Events such as these cause the output to be deactivated (tripped) and the event to be indicated on the display on the front panel of the module (the LED corresponding to the channel flashes, the **I/O** LED comes on).
- **Reversal of polarity.** An event such as this causes the power supply to short circuit without damaging the module. In order to obtain optimal protection, a quick-blow fuse must be installed on the power supply and upstream from the pre-actuators.
- **Inductive overvoltage.** Each output is individually protected against inductive overvoltage and has a fast electro-magnet demagnetization circuit using a zener diode which allows the mechanical cycle of certain fast machines to be reduced.

DC Inputs

24 VDC and 48 VDC inputs are of constant current type. The input current is constant for a voltage greater than:

- 15 V for 24 VDC inputs
- 25 V for the 48 VDC inputs

This characteristic has the following advantages:

- guaranteed minimum current in active state in accordance with IEC standards
- limited consumed current when input voltage increases, to avoid the module overheating unnecessarily
- reduced consumed current to the power supply sensor supplied by the PLC power supply or a process power supply

Module and Channel Status Display

At a Glance

The discrete I/O modules are equipped with a display block featuring LEDs that displays the module's channels status the overall module status.

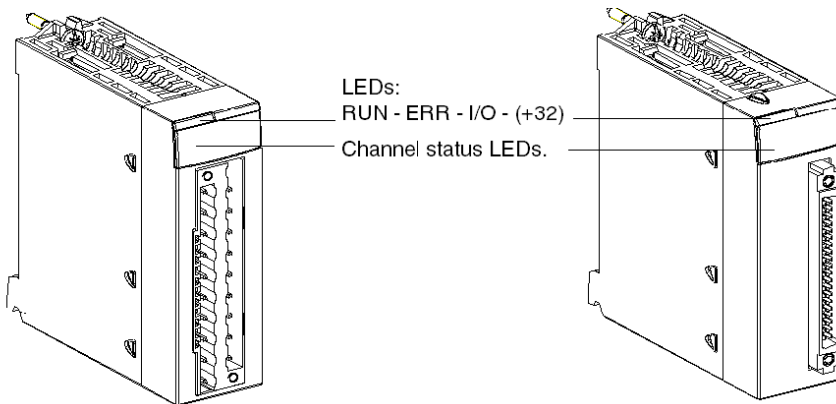

Illustration

The figure below shows the position of the channel status display LEDs as well as the 3 (or 4) module status LEDs, on the front panel of the discrete I/O modules.



Description

The following table explains how the LEDs located on the discrete I/O display block operate.

LEDs	Continually Lit 	Flashing 	Off 
RUN (green)	module operating normally	N/A	module inoperative or off
ERR (red)	internal event: Module analysis needed	Communication loss between the discrete module and the CPU	no detected internal error
I/O (red)	external event: overload, short circuit, sensor/pre-actuator voltage error	Terminal block incorrectly wired	no detected external error
+32 Green	selection of channels 32 to 63	N/A	selection of channels 0 to 31
Channel status	channel at 1	channel error, overload, short circuit, or open wire detected ⁽¹⁾	channel at 0
<p>(1) When channel status is open wire detected, the flashing timing is the following:</p> <ul style="list-style-type: none"> • 64 ms ON • 64 ms OFF • 64 ms ON • 2000 ms OFF 			

NOTE: The **+32** LED is only present on the 64-channel modules. It is enabled/disabled with a push-button located on the top of the module. By default, the first 32 channels are displayed.

NOTE: For a mixed input/output module, the first line of channel status LEDs represents the inputs (for example, for a mixed 16 input/16 output module, LEDs 0 to 15 represent the inputs and LEDs 16 to 31 represent the outputs).

NOTE: After the sensor power outage, the I/O (red) LED of the following modules switch on and the last recorded position of the sensor is displayed by the input channel status LED's:

- BMX DDI 1602
- BMX DDI 1603
- BMX DDI 1604T
- BMX DDI 3202K
- BMX DDI 6402K
- BMX DDM 16022
- BMX DDM 3202K
- BMX DDM 16025

▲ WARNING

CHANNEL LED INFORMATION NOT MATCHING SENSORS POSITION

After a sensor power outage:

- The I/O error LED is on
- Do not take into account the input LEDs information (they show the last recorded position of the sensors, not their real positions)
- Check the real positions on the sensors.

Failure to follow these instructions can result in death, serious injury, or equipment damage.

Display Panels

When a voltage is present on an input or output, the corresponding LED is lit.

Display of internal or external events is only effective once the module has been configured. After powering-up or a cold start, all the LEDs flash twice (for 2 seconds) to show that the module is operational. When an event is detected, the channel status is recorded until the cause of the event is cleared.

There are several display blocks depending on the type of discrete I/O module.

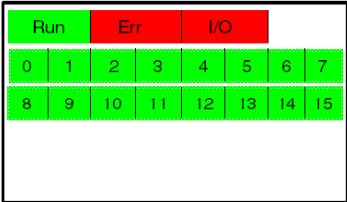
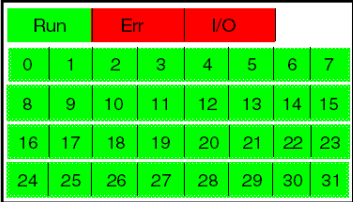
Modules	Display Panel illustration	Description
BMX DAI 0805 BMX DAI 0814 BMX DRA 0804T BMX DRA 0805 BMX DRA 0815 BMX DRC 0805		These modules have: <ul style="list-style-type: none"> • 3 module status LEDs: RUN - ERR - I/O • 8 channel status LEDs
BMX DDI 1602 BMX DDI 1603 BMX DDI 1604T BMX DAI 1602 BMX DAI 1603 BMX DAI 1604 BMX DAI 1614 BMX DAI 1615 BMX DDO 1602 BMX DDO 1612 BMX DRA 1605 BMX DAO 1605 BMX DAO 1615		These modules have: <ul style="list-style-type: none"> • 3 module status LEDs: RUN - ERR - I/O • 16 channel status LEDs
BMX DDI 3203 BMX DDI 3232 BMX DDI 3202 K BMX DDO 3202 K BMX DDM 3202 K BMX DDM 16022 ⁽¹⁾ BMX DDM 16025 ⁽¹⁾		These modules have: <ul style="list-style-type: none"> • 3 module status LEDs: RUN - ERR - I/O • 32 channel status LEDs

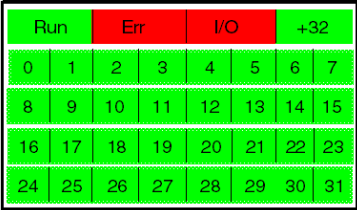
Modules	Display Panel illustration	Description
BMX DDI 6402 K BMX DDO 6402 K		These modules have: <ul style="list-style-type: none"> • 3 module status LEDs: RUN - ERR - I/O • a +32 LED to display channels 32 to 63 • 32 channel status LEDs • a switch to display channels 32 to 63
(1) The BMX DDM 16022 and BMX DDM 16025 mixed input/output modules have 2 groups of 8 channels. The input group is represented by channels 0 to 7 and the output group is represented by channels 16 to 23.		

Diagnostics

At a Glance

The diagnostics function detects any conditions that may affect module operation. Three diagnostic groups can be identified:

- internal events
- external events
- other events

Internal Events

Internal events concern all internal module conditions and all communication loss occurrences that prevent a discrete input/output module from operating correctly.

A communication loss can be caused by:

- a hardware detected fault at rack bus level
- a processor malfunction or power cable circuit open or short
- a power cable circuit open or short

External Events

External events include:

- **Overload and Short-Circuit:** Static output modules contain a device for checking the load status. In the event of an overload or short-circuit of one or more outputs, they are

tripped to open circuit. The status will be shown on the front panel of the module - the LEDs corresponding to the tripped outputs will flash and the red **I/O** LED will light up.

- **Sensor Voltage Error:** All input modules contain a device for checking sensor voltage for all module channels. This device checks that sensor and module power supply voltages are of a sufficiently high level for correct operation of the module's input channels. When sensor voltage is less than or equal to the defined threshold, the status is shown by the **I/O** LED lighting up on front panel of the module.
- **Pre-actuator Voltage Error:** All 24 VDC and 48 VDC transistor output modules contain a device for checking the pre-actuator voltage of all module channels. This device checks that pre-actuator and module power supply voltages are of a sufficiently high level for correct operation of the module's output channels. This voltage must be greater than 18 V (24 VDC supply) or 36 V (48 VDC supply) for modules with direct current static outputs. In the event of pre-actuator voltage being less than or equal to this threshold, the error is shown by the **I/O** LED lighting up on the front panel of the module.
- **Open wire Error:** Some modules (for example BMXDAI1614/DAI1615) can detect the open wire error by checking the leakage current in the loop. In order to get the appropriate leakage current, an external resistor might be required. See details in the characteristic page of the specific module.

NOTE: The sensor/pre-actuator voltage check is unique to terminal block modules. In 32 or 64-channel connector modules, there is one checking device per connector (equivalent to one per group of 16 channels).

A sensor or pre-actuator voltage error leads to all the inputs and outputs of the group affected by the error (i.e. groups of 8 or 16 channels for a terminal block module and the group of 16 channels for a 32 or 64-channel connector module) to be set to inactive.

After a power sensor outage, if the **Supply monitoring** check box is not selected in the module configuration screen then the digital input can stay active.

WARNING

DIGITAL INPUT STATE INACTIVE AFTER A SENSOR POWER OUTAGE

Do not click to clear the **Supply monitoring** check box in the module configuration screen to guarantee the digital input state inactive after sensor power outage.

Failure to follow these instructions can result in death, serious injury, or equipment damage.

To access the **Supply monitoring** check box, refer to chapter *How to Modify the External Power Supply Error Monitoring Parameter*, page 351.

























NOTE: Relay output modules do not contain pre-actuator voltage checking devices.

Other Events

The other errors category includes loss of power to the modules.

Description

The following table can be used to determine the module's status on the basis of the LEDs located on the discrete input/output modules' display panel.

State of module		LEDs		
		RUN (green)	ERR (red)	I/O (red)
Normal operation				
Internal events	Module analysis needed			
	CPU communication interruption			
External events	Overload, short circuit, sensor/pre-actuator voltage error, open wire			
Configuration	Self-test of the module at start-up			
	Not configured module			
Other events	Module loss of power			
Key:				
		LED on		
		LED flashing		
		LED off		

NOTE: After the sensor power outage, the I/O (red) LED of the following modules switch on and the last recorded position of the sensor is displayed by the input channel status LED's:

- BMX DDI 1602
- BMX DDI 1603
- BMX DDI 1604T
- BMX DDI 3202K
- BMX DDI 6402K
- BMX DDM 16022
- BMX DDM 3202K
- BMX DDM 16025

▲ WARNING

CHANNEL LED INFORMATION NOT MATCHING SENSORS POSITION

After a sensor power outage:

- The I/O error LED is on
- Do not take into account the input LEDs information (they show the last recorded position of the sensors, not their real positions)
- Check the real positions on the sensors.

Failure to follow these instructions can result in death, serious injury, or equipment damage.

Checking the Connection

At a Glance

In order to check the discrete I/O connection, ensure that:

- sensor data is registered by the corresponding inputs and by the processor
- control orders from the processor are registered by the outputs and transmitted to the corresponding pre-actuators

⚠ WARNING

UNEXPECTED EQUIPMENT OPERATION

Active outputs can activate machine movements.

All power must be turned off before this check is carried out:

1. remove power fuses from the motor controls
2. turn off the power of hydraulic and pneumatic units
3. power up the PLC fitted with its Discrete I/O modules

Failure to follow these instructions can result in death, serious injury, or equipment damage.

Description

After this, it is possible to check the connection of the Discrete I/O modules:

- **without a terminal:** activate each sensor and check whether the corresponding input LED changes. If it remains unchanged, check the wiring and correct operation of the sensor.
- **with a terminal** (more in-depth check on the connection of the inputs/outputs). An application with configured I/Os in the PLC is required, even if it is empty (in that case, do not declare any module in the 'FAST task').
 - This check can be carried out with the PLC in **RUN** mode, from a PC equipped with Control Expert software giving access to debug functions.
 - This check can also be carried out with an entire application loaded in the memory. In this case, stop the processing of the program by de-activating the MAST, FAST and event , page 350tasks by setting system bits %S30, %S31, and %S38 to 0.

Input Check

The following table shows the procedure for checking input connections.

Step	Action
1	Activate each sensor and check that the corresponding input LED changes status.
2	Check on the terminal screen that the corresponding input bit (%I•) also changes status.

Output Check

The following table shows the procedure for checking output connections.

Step	Action
1	From the terminal, set each bit (%Q•) that corresponds to an output to 1 then 0.
2	Check that the corresponding output LED turns on then off and that the corresponding pre-actuator activates then de-activates.

BMX DDI 1602 Input Modules

What's in This Chapter

Introduction	102
Characteristics.....	103
Connecting the Module	105

Subject of this Section

This section presents the BMX DDI 1602 module, its characteristics, and explains how it is connected to the various sensors.

Introduction

Function

The BMX DDI 1602 module is a 24 VDC discrete module connected via a 20-pin terminal block. It is a positive logic (or sink) module: its 16 input channels receive current from the sensors.

Ruggedized Version

The BMX DDI 1602H (hardened) equipment is the ruggedized version of the BMX DDI 1602 (standard) equipment. It can be used at extended temperatures and in harsh chemical environments.

For more information, refer to chapter *Installation in More Severe Environments* (see Modicon M580, M340, and X80 I/O Platforms, Standards and Certifications).

Illustration

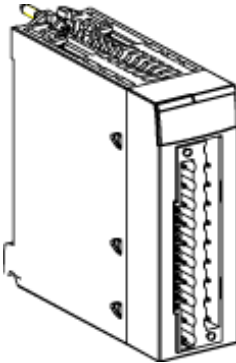

Characteristics

Altitude Operating Conditions

The characteristics in the table below apply to the modules BMX DDI 1602 and BMX DDI 1602H for use at altitude up to 2000 m (6560 ft). When the modules operate above 2000 m (6560 ft), apply additional derating.

For detailed information, refer to chapter *Operating and Storage Conditions* (see Modicon M580, M340, and X80 I/O Platforms, Standards and Certifications).

General Characteristics

This table presents the general characteristics for the BMX DDI 1602 and BMX DDI 1602H modules:

Module type		24 VDC positive logic inputs	
Operating temperature	BMX DDI 1602	0...60 °C (32...140 °F)	
	BMX DDI 1602H	-25...70 °C (-13...158 °F)	
Nominal input values		Voltage	24 VDC
		Current	3.5 mA
Threshold input values	At 1	Voltage	≥ 11 V
		Current	> 2 mA (for U ≥ 11 V)
	At 0	Voltage	5 V
		Current	< 1.5 mA

	Sensor supply (including ripple for standard module)	19...30 V (possible up to 34 V, limited to 1 hour/day)
Input impedance	At nominal U	6.8 kΩ
Response time	Typical	4 ms
	Maximum	7 ms
Reliability	MTBF for continuous operation in hours at ambient temperature 30 °C (86 °F)	738 749
Reverse polarity		Protected
Fuse type	Internal	None
	External	1 fast blow fuse of 0.5 A
Input type		Current sink
Input type in compliance with IEC 61131-2 standard		Type 3
2-wire / 3-wire proximity sensor compatibility (IEC 60947-5-2 standard compliant)		2-wire (DC), and 3-wire (DC) PNP any type, page 87
Dielectric strength		1500 V actual, 50 / 60 Hz for 1 min.
Resistance of insulation		>10 MΩ (below 500 VDC)
Paralleling of inputs⁽¹⁾		Yes
Sensor voltage: monitoring threshold	OK	> 18 VDC
	Error	< 14 VDC
Sensor voltage: monitoring response time at 24 V (-15% ... +20%)	On appearance	1 ms < T < 3 ms
	On disappearance	8 ms < T < 30 ms
Power consumption 3.3 V	Typical	76 mA
	Maximum	107 mA
Sensor supply consumption	Typical	46 mA
	Maximum	73 mA
Power dissipation		2.5 W max.
(1) This characteristic is used to connect several inputs to the same module in parallel or to different modules for input redundancy.		

NOTE: For the BMX DDI 1602H, the maximum value of the sensor power supply must not exceed 26.4 V when operated at 70 °C (158 °F).

⚠ WARNING

OVERHEATING MODULE

Do not operate the BMX DDI 1602H at 70 °C (158 °F) if the sensor power supply is greater than 26.4 V or less than 21.1 V.

Failure to follow these instructions can result in death, serious injury, or equipment damage.

Connecting the Module

At a Glance

The BMX DDI 1602 module is fitted with a removable 20-pin terminal block for the connection of sixteen input channels.

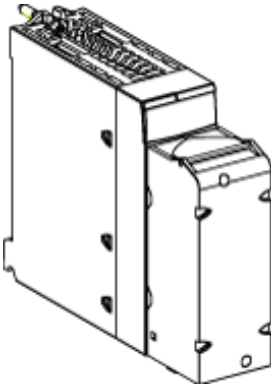

Input Circuit Diagram

The following diagram shows the circuit of a direct current input (positive logic).

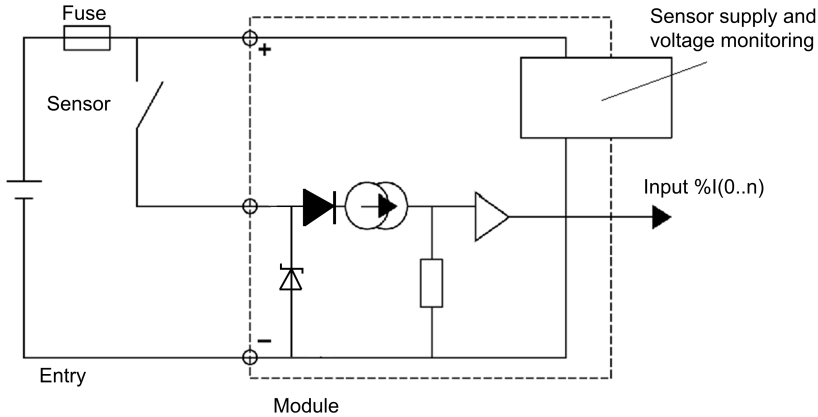

Module Connection

⚡ ⚠ DANGER
HAZARD OF ELECTRICAL SHOCK, EXPLOSION OR ARC FLASH
Switch off the sensor and pre-actuator voltages before connecting or disconnecting the module.
Failure to follow these instructions will result in death or serious injury.

⚠ CAUTION
LOSS OF INPUT FUNCTION
Install the correct rating and type of fuse.
Failure to follow these instructions can result in injury or equipment damage.

The following diagram shows the connection of the module to the sensors.

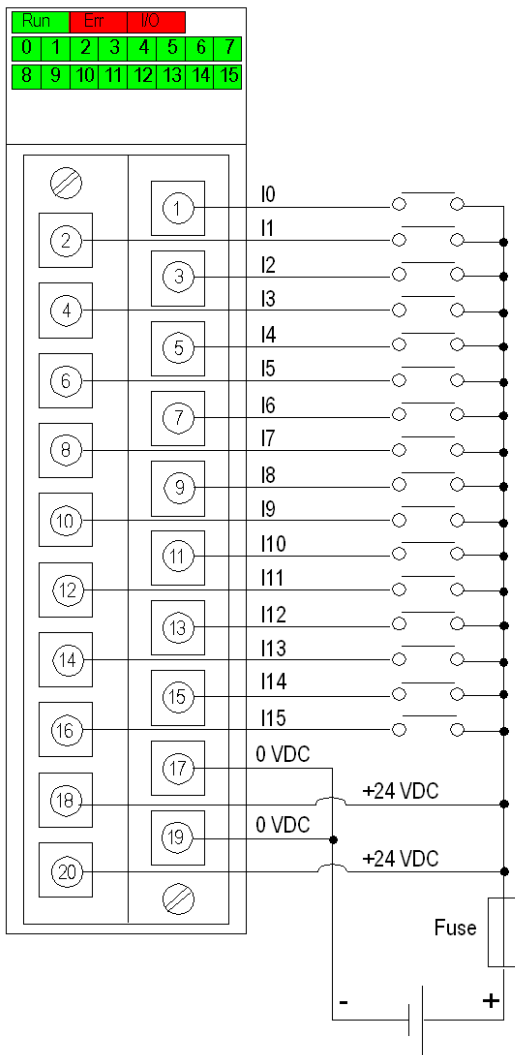

power supply: 24 VDC

fuse: fast blow fuse of 0.5A

Sensor Power Outage

After a power sensor outage, if the **Supply monitoring** check box is not selected in the module configuration screen then the digital input can stay active.

WARNING

DIGITAL INPUT STATE INACTIVE AFTER A SENSOR POWER OUTAGE

Do not click to clear the **Supply monitoring** check box in the module configuration screen to guarantee the digital input state inactive after sensor power outage.

Failure to follow these instructions can result in death, serious injury, or equipment damage.

To access the **Supply monitoring** check box, refer to chapter *How to Modify the External Power Supply Error Monitoring Parameter*, page 351.

After the sensor power outage, the I/O (red) LED of the module switches on and the last recorded position of the sensor is displayed by the input channel status LED's.

WARNING

CHANNEL LED INFORMATION NOT MATCHING SENSORS POSITION

After a sensor power outage:

- The I/O error LED is on
- Do not take into account the input LEDs information (they show the last recorded position of the sensors, not their real positions)
- Check the real positions on the sensors.

Failure to follow these instructions can result in death, serious injury, or equipment damage.

BMX DDI 1603 Input Modules

What’s in This Chapter

Introduction	109
Characteristics.....	110
Connecting the Module	112

Subject of this Section

This section presents the BMX DDI 1603 module, its characteristics, and explains how it is connected to the various sensors.

Introduction

Function

The BMX DDI 1603 module is a 48 VDC discrete module connected via a 20-pin terminal block. It is a positive logic (or sink) module: its 16 input channels receive current from the sensors.

Ruggedized Version

The BMX DDI 1603H (hardened) equipment is the ruggedized version of the BMX DDI 1603 (standard) equipment. It can be used at extended temperatures and in harsh chemical environments.

For more information, refer to chapter *Installation in More Severe Environments* (see Modicon M580, M340, and X80 I/O Platforms, Standards and Certifications).

Illustration

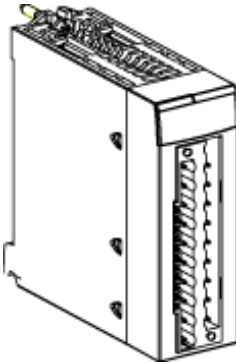

Characteristics

Altitude Operating Conditions

The characteristics in the table below apply to the modules BMX DDI 1603 and BMX DDI 1603H for use at altitude up to 2000 m (6560 ft). When the modules operate above 2000 m (6560 ft), apply additional derating.

For detailed information, refer to chapter *Operating and Storage Conditions* (see Modicon M580, M340, and X80 I/O Platforms, Standards and Certifications).

General Characteristics

This table presents the general characteristics for the BMX DDI 1603 and BMX DDI 1603H modules:

Module type		48 VDC positive logic inputs	
Operating temperature	BMX DDI 1603	0...60 °C (32...140 °F)	
	BMX DDI 1603H	-25...70 °C (-13...158 °F)	
Nominal input values		Voltage	48 VDC
		Current	2.5 mA
Threshold input values	At 1	Voltage	≥ 34 V
		Current	> 2 mA (for U ≥ 34 V)
	At 0	Voltage	10 V
		Current	< 0.5 mA

	Sensor supply (including ripple)	36...60 V
Input impedance	At nominal U	19.2 kΩ
Response time	Typical	4 ms
	Maximum	7 ms
Reliability	MTBF for continuous operation in hours at ambient temperature (30° C) (86°F)	738 749
Reverse polarity		Protected
Fuse type	Internal	None
	External	Fast blow fuse of 0.5 A
Input type		Current sink
Input type in compliance with IEC 61131-2 standard		Type 1
2-wire / 3-wire proximity sensor compatibility (IEC 60947-5-2 standard compliant)		2-wire (DC), and 3-wire (DC) PNP any type, page 87
Dielectric strength		1 500 V actual, 50 / 60 Hz for 1 min.
Resistance of insulation		>10 MΩ (below 500 VDC)
Paralleling of inputs⁽¹⁾		Yes
Sensor voltage: monitoring threshold	OK	> 36 VDC
	Error	< 24 VDC
Sensor voltage: monitoring response time at 24 V (-15% ... +20%)	On appearance	1 ms < T < 3 ms
	On disappearance	8 ms < T < 30 ms
Power consumption 3.3 V	Typical	76 mA
	Maximum	107 mA
Sensor supply consumption	Typical	47 mA
	Maximum	60 mA
Power dissipation		3.6 W max.
(1) This characteristic is used to connect several inputs to the same module in parallel or to different modules for input redundancy.		

NOTE: For the **BMX DDI 1603H**, the maximum value of the sensor power supply must not exceed 52.8 V when operated at 70 °C (158 °F).

⚠ WARNING

OVERHEATING MODULE

Do not operate the **BMX DDI 1603H** at 70 °C (158 °F) if the sensor power supply is greater than 52.8 V or less than 42.2 V.

Failure to follow these instructions can result in death, serious injury, or equipment damage.

Connecting the Module

At a Glance

The BMX DDI 1603 module is fitted with a removable 20-pin terminal block for the connection of sixteen input channels.

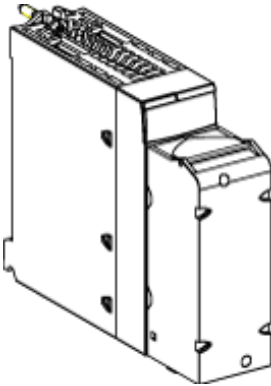

Input Circuit Diagram

The following diagram shows the circuit of a direct current input (positive logic).

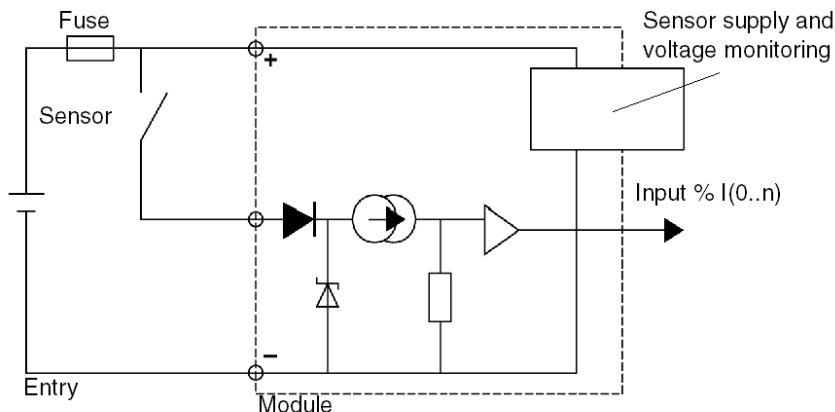

Module Connection

⚡ ⚠ DANGER

HAZARD OF ELECTRICAL SHOCK, EXPLOSION OR ARC FLASH

Switch off the sensor and pre-actuator voltages before connecting or disconnecting the module.

Failure to follow these instructions will result in death or serious injury.

⚠ CAUTION

LOSS OF INPUT FUNCTION

Install the correct type of fuse with the correct rating.

Failure to follow these instructions can result in injury or equipment damage.

The following diagram shows the connection of the module to the sensors.

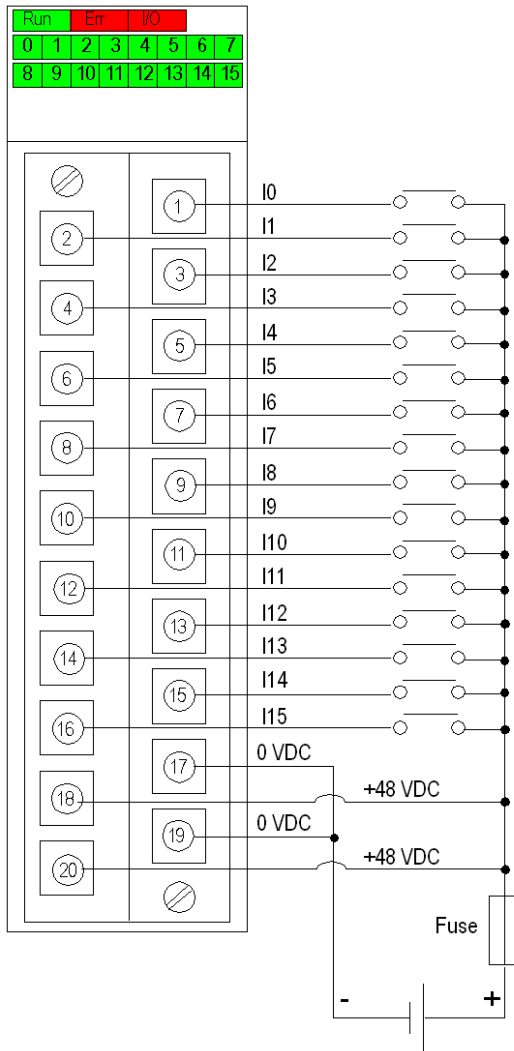

power supply: 48 VDC

fuse: fast blow fuse of 0.5A

Sensor Power Outage

After a power sensor outage, if the **Supply monitoring** check box is not selected in the module configuration screen then the digital input can stay active.

WARNING

DIGITAL INPUT STATE INACTIVE AFTER A SENSOR POWER OUTAGE

Do not click to clear the **Supply monitoring** check box in the module configuration screen to guarantee the digital input state inactive after sensor power outage.

Failure to follow these instructions can result in death, serious injury, or equipment damage.

To access the **Supply monitoring** check box, refer to chapter *How to Modify the External Power Supply Error Monitoring Parameter*, page 351.

After the sensor power outage, the I/O (red) LED of the module switches on and the last recorded position of the sensor is displayed by the input channel status LED's.

WARNING

CHANNEL LED INFORMATION NOT MATCHING SENSORS POSITION

After a sensor power outage:

- The I/O error LED is on
- Do not take into account the input LEDs information (they show the last recorded position of the sensors, not their real positions)
- Check the real positions on the sensors.

Failure to follow these instructions can result in death, serious injury, or equipment damage.

BMX DDI 1604T Input Modules

What's in This Chapter

Introduction	116
Characteristics.....	117
Connecting the Module	120

Subject of this Section

This section presents the BMX DDI 1604T module, its characteristics, and explains how it is connected to the various sensors.

NOTE: There is no H version of this module.

Introduction

Function

The BMX DDI 1604T module is a 125 VDC discrete module connected via a 20-pin terminal block. It is a positive logic (or sink) module: its 16 input channels receive current from the sensors.

NOTE: BMX DDI 1604T provides an extended temperature range, as listed in the General Characteristics, page 117 topic of this chapter.

Illustration

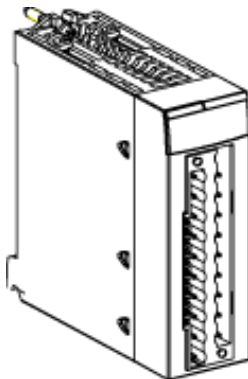

Characteristics

Altitude Operating Conditions

The characteristics in the table below apply to the module BMX DDI 1604T for use at altitude up to 2000 m (6560 ft). When the module operates above 2000 m (6560 ft), apply additional derating.

For detailed information, refer to chapter *Operating and Storage Conditions* (see Modicon M580, M340, and X80 I/O Platforms, Standards and Certifications).

General Characteristics

This table presents the general characteristics for the BMX DDI 1604T module:

Module type		125 VDC positive logic inputs	
Operating temperature		-25...70 °C (-13...158 °F)	
Temperature derating		Apply the temperature derating curve (see the graph below the table).	
Nominal input values		Voltage	125 VDC
		Current	2.4 mA
Threshold input values	At 1	Voltage	≥ 88 VDC
		Current	> 2 mA (for U ≥ 88 V)
	At 0	Voltage	36 VDC
		Current	< 0.5 mA
	Sensor supply (including ripple for standard module)		100...150 V (156 V including ripple)
Input impedance	At nominal U	50 kΩ	
Response time	Typical	5 ms	
	Maximum	9 ms	
Reliability	MTBF for continuous operation in hours at ambient temperature 30 °C (86 °F)	888 402	
Reverse polarity		Protected	
Fuse type	Internal	None	
	External	Fast blow fuse of 0.5 A	

Dielectric strength		2500 VDC for 1 min.
Resistance of insulation		>10 MΩ (below 500 VDC)
Type of input		Current sink
Paralleling of inputs		Yes
Sensor voltage: monitoring threshold	I/O LED off	> 100 VDC
	I/O LED on	< 80 VDC
Sensor voltage: monitoring response time at 125 VDC (-20% ... +20%)	On appearance	8 ms < T < 30 ms
	On disappearance	1 ms < T < 5 ms
Power consumption 3.3 V	Typical	76 mA
	Maximum	107 mA
Sensor supply consumption 4-channel at 70°C	Typical	1.85 W
	Maximum	2.85 W
Sensor supply consumption 8-channel at 60°C	Typical	3.07 W
	Maximum	4.61 W
Sensor supply consumption 12-channel at 50°C	Typical	4.29 W
	Maximum	6.37 W
Sensor supply consumption 16-channel at -25...40°C	Typical	5.51 W
	Maximum	8.13 W
Power dissipation		3.2 W max. at 70 °C
		5.0 W max. at 60 °C
		6.7 W max. at 50 °C
		8.5 W max. at 40 °C
Input operating voltage range		88...150 VDC
Maximum input voltage		156 VDC (including ripple)

The following graph shows the temperature derating of BMX DDI 1604T.

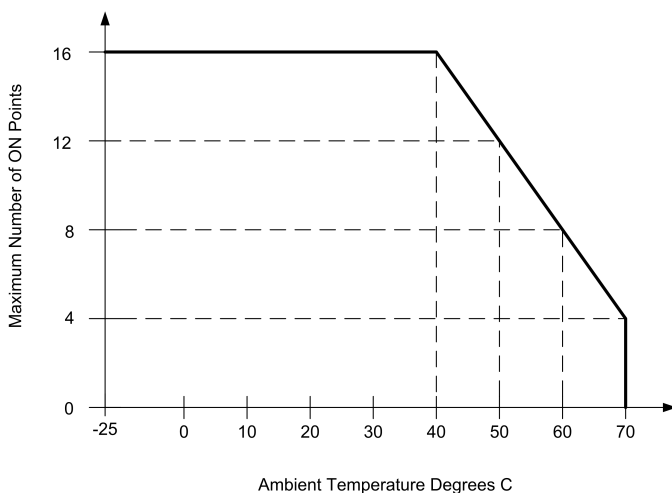

NOTE: For the **BMX DDI 1604T**, the maximum value of the sensor power supply must not exceed 150 V when operated at 70 °C (158 °F).

▲ WARNING

OVERHEATING MODULE

Do not operate the **BMX DDI 1604T** at 70 °C (158 °F) if the sensor power supply is greater than 150 V or less than 100 V.

Failure to follow these instructions can result in death, serious injury, or equipment damage.

Connecting the Module

At a Glance

The BMX DDI 1604T module is fitted with a removable 20-pin terminal block for the connection of sixteen input channels.

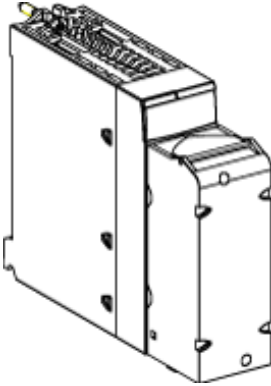

Input Circuit Diagram

The following diagram shows the circuit of a direct current input (positive logic).

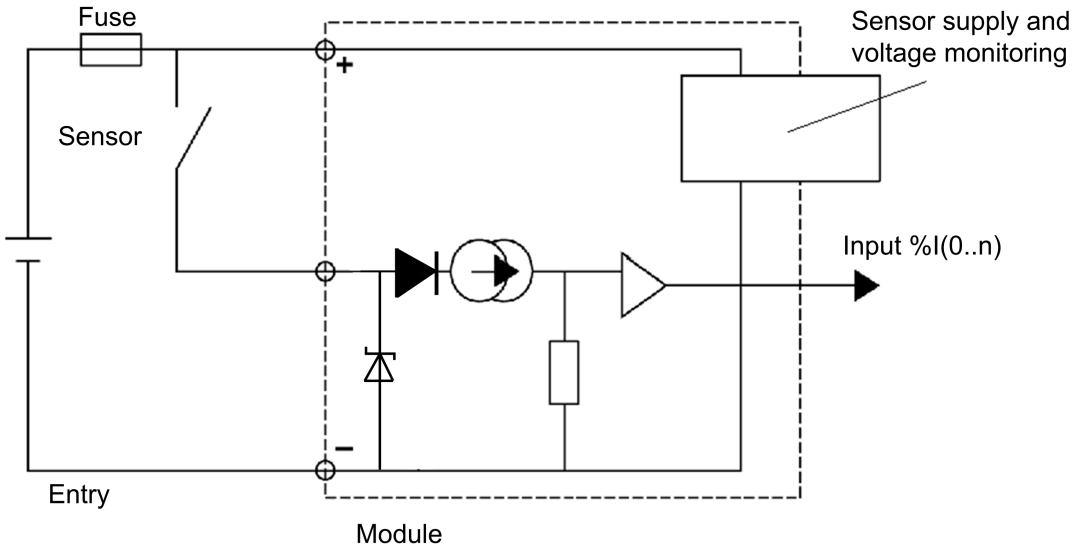

Module Connection

DANGER

HAZARD OF ELECTRICAL SHOCK, EXPLOSION OR ARC FLASH

Switch off the sensor and pre-actuator voltages before connecting or disconnecting the module.

Failure to follow these instructions will result in death or serious injury.

CAUTION

LOSS OF INPUT FUNCTION

Install the correct rating and type of fuse.

Failure to follow these instructions can result in injury or equipment damage.

The following diagram shows the connection of the module to the sensors.

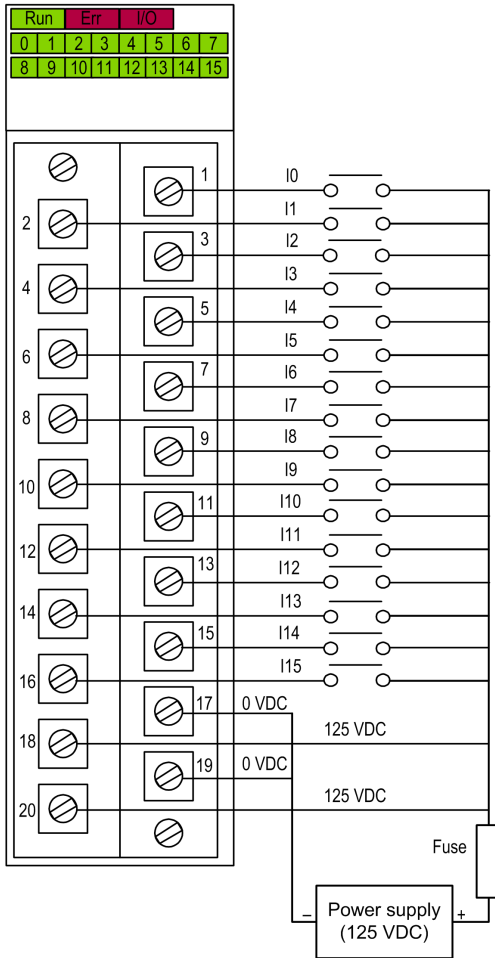

Fuse Fast blow fuse of 0.5 A

Sensor Power Outage

After a power sensor outage, if the **Supply monitoring** check box is not selected in the module configuration screen then the digital input can stay active.

⚠ WARNING

DIGITAL INPUT STATE INACTIVE AFTER A SENSOR POWER OUTAGE

Do not click to clear the **Supply monitoring** check box in the module configuration screen to guarantee the digital input state inactive after sensor power outage.

Failure to follow these instructions can result in death, serious injury, or equipment damage.

To access the **Supply monitoring** check box, refer to chapter *How to Modify the External Power Supply Error Monitoring Parameter*, page 351.

After the sensor power outage, the I/O (red) LED of the module switches on and the last recorded position of the sensor is displayed by the input channel status LED's.

⚠ WARNING

CHANNEL LED INFORMATION NOT MATCHING SENSORS POSITION

After a sensor power outage:

- The I/O error LED is on
- Do not take into account the input LEDs information (they show the last recorded position of the sensors, not their real positions)
- Check the real positions on the sensors.

Failure to follow these instructions can result in death, serious injury, or equipment damage.

BMX DDI 3203 Input Modules

What's in This Chapter

Introduction	124
Characteristics.....	125
Connecting the Module	127

This section presents the BMX DDI 3203 module, its characteristics, and explains how it is connected to the various sensors.

Introduction

Function

The BMX DDI 3203 module is a 48 VDC discrete module connected via a 40-pin terminal block. It is a positive logic (or sink) module: its 32-input channels receive current from the sensors.

Ruggedized Version

The BMX DDI 3203H (hardened) equipment is the ruggedized version of the BMX DDI 3203 (standard) equipment. It can be used at extended temperatures and in harsh chemical environments.

For more information, refer to chapter *Installation in More Severe Environments* (see Modicon M580, M340, and X80 I/O Platforms, Standards and Certifications).

Illustration

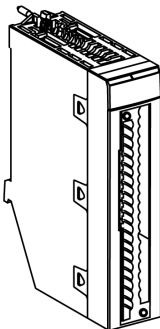

Characteristics

Altitude Operating Conditions

The characteristics in the table below apply to the modules BMX DDI 3203 and BMX DDI 3203H for use at altitude up to 2000 m (6560 ft). When the modules operate above 2000 m (6560 ft), apply additional derating.

For detailed information, refer to chapter *Operating and Storage Conditions* (see Modicon M580, M340, and X80 I/O Platforms, Standards and Certifications).

General Characteristics

This table presents the general characteristics for the BMX DDI 3203 and BMX DDI 3203H modules.

Module type		48 VDC positive logic inputs	
Operating temperature	BMX DDI 3203	0...60 °C (32...140 °F)	
	BMX DDI 3203 H	-25...70 °C (-13...158 °F)	
Nominal input values	Voltage	48 VDC	
	Current	2.3 mA	
Threshold input values	At 1	Voltage	≥ 30 V
		Current	> 2 mA (for $U \geq 30$ V)
	At 0	Voltage	≤ 10 V
		Current	< 1.5 mA (for $U \leq 10$ V)
	Sensor supply (including ripple)		38...60 V
	Input impedance	at nominal U	20.96 k Ω
Response time	typical	4 ms	
	maximum	7 ms	
Reliability	MTBF in hours at ambient temperature 30 °C (86 °F)	706 489	
Reverse polarity		Protected	
Fuse type	Internal	None	
	External	Fast blow fuse of 0.5 A	
Input type		Current sink	

Input type in compliance with IEC 61131-2 standard		Type 3
2-wire / 3-wire proximity sensor compatibility (IEC 60947-5-2 standard compliant)		2-wire (DC), and 3-wire (DC) PNP any type, page 87
Dielectric strength	Primary/Secondary	1500 V actual, 50 / 60 Hz for 1 min.
	Between channel groups	500 VDC
Resistance of insulation		>10 M Ω (below 500 VDC)
Paralleling of inputs⁽¹⁾		Yes
Sensor voltage: monitoring threshold	OK	> 36 VDC
	Error	< 24 VDC
Sensor voltage: monitoring response time at 24 V (-15% ... +20%)	on appearance	1 ms < T < 3 ms
	on disappearance	8 ms < T < 30 ms
Power consumption 3.3 V	Typical	100 mA
	Maximum	130 mA
Power consumption 24 V	Typical	110 mA
	Maximum	125 mA
Sensor supply consumption⁽²⁾	Typical	4.6 mA
	Maximum	5.2 mA
Power dissipation		6 W max.
Temperature derating for BMX DDI 3203		None
<p>(1) This characteristic is used to connect several inputs to the same module in parallel or to different modules for input redundancy.</p> <p>(2) The BMX DDI 3203(H) module has a maximum value of 52.8 V when operated above 60 °C (140 °F).</p>		

WARNING

OVERHEATING MODULE

Do not operate the **BMX DDI 3203 H** above 60 °C (140 °F) if the sensor power supply is greater than 52.8 V.

Failure to follow these instructions can result in death, serious injury, or equipment damage.

Connecting the Module

At a Glance

The BMX DDI 3203 module is fitted with a removable 40-pin terminal block for the connection of thirty-two input channels.

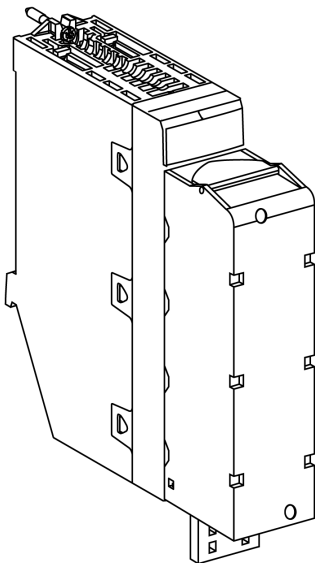

Input Circuit Diagram

The following diagram shows the circuit of a direct current input (positive logic).

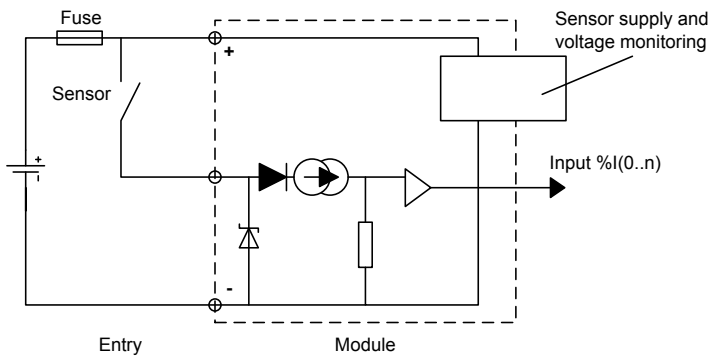

Module Connection

DANGER

HAZARD OF ELECTRICAL SHOCK, EXPLOSION OR ARC FLASH

Switch off the sensor and pre-actuator voltages before connecting or disconnecting the module.

Failure to follow these instructions will result in death or serious injury.

CAUTION

LOSS OF INPUT FUNCTION

Install the correct type of fuse with the correct rating.

Failure to follow these instructions can result in injury or equipment damage.

The following diagram shows the connection of the sensors to the module.

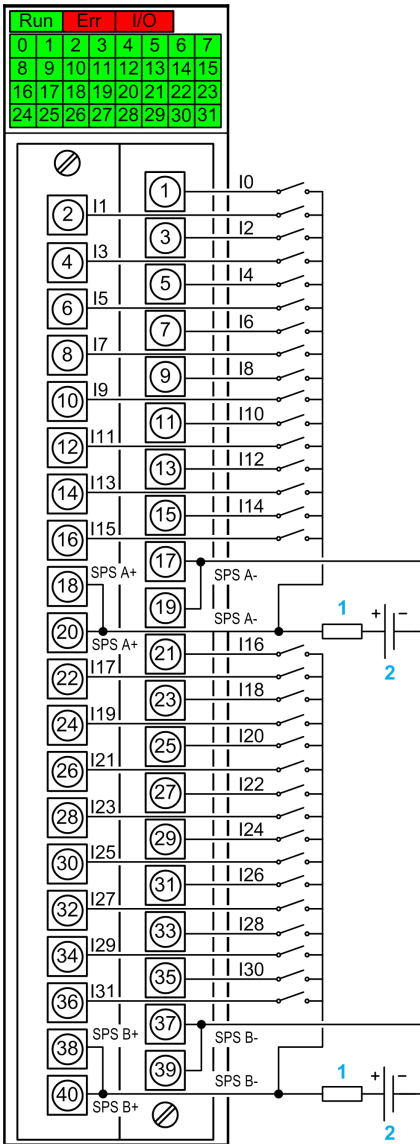

1 fast blow fuse of 0.5A

2 Sensor power supply (SPS) 48 VDC

Sensor Power Outage

After a power sensor outage, if the **Supply monitoring** check box is not selected in the module configuration screen then the digital input can stay active.

WARNING

DIGITAL INPUT STATE INACTIVE AFTER A SENSOR POWER OUTAGE

Do not click to clear the **Supply monitoring** check box in the module configuration screen to guarantee the digital input state inactive after sensor power outage.

Failure to follow these instructions can result in death, serious injury, or equipment damage.

To access the **Supply monitoring** check box, refer to chapter *How to Modify the External Power Supply Error Monitoring Parameter*, page 351.

After the sensor power outage, the I/O (red) LED of the module switches on and the last recorded position of the sensor is displayed by the input channel status LED's.

WARNING

CHANNEL LED INFORMATION NOT MATCHING SENSORS POSITION

After a sensor power outage:

- The I/O error LED is on
- Do not take into account the input LEDs information (they show the last recorded position of the sensors, not their real positions)
- Check the real positions on the sensors.

Failure to follow these instructions can result in death, serious injury, or equipment damage.

BMX DDI 3232 Input Modules

What's in This Chapter

Introduction	131
Characteristics.....	132
Connecting the Module	134

This section presents the BMX DDI 3232 module, its characteristics, and explains how it is connected to the various sensors.

Introduction

Function

The BMX DDI 3232 module is a 12 VDC/24 VDC discrete module connected via a 40-pin terminal block. It is a positive or negative logic (sink or source) module: its 32-input channels receive current from the sensors.

Ruggedized Version

The BMX DDI 3232H (hardened) equipment is the ruggedized version of the BMX DDI 3232 (standard) equipment. It can be used at extended temperatures and in harsh chemical environments.

For more information, refer to chapter *Installation in More Severe Environments* (see Modicon M580, M340, and X80 I/O Platforms, Standards and Certifications).

Illustration

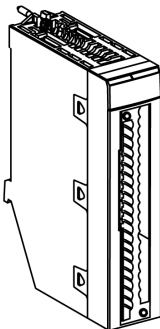

Characteristics

Altitude Operating Conditions

The characteristics in the table below apply to the modules BMX DDI 3232 and BMX DDI 3232H for use at altitude up to 2000 m (6560 ft). When the modules operate above 2000 m (6560 ft), apply additional derating.

For detailed information, refer to chapter *Operating and Storage Conditions* (see Modicon M580, M340, and X80 I/O Platforms, Standards and Certifications).

General Characteristics

This table presents the general characteristics for the BMX DDI 3232 and BMX DDI 3232H modules.

Module type		12 VDC/24 VDC positive or negative logic inputs	
Operating temperature	BMX DDI 3232	0...60 °C (32...140 °F)	
	BMX DDI 3232H	-25...70 °C (-13...158 °F)	
Nominal input values	Voltage	12 VDC/24 VDC	
	Current	3.3 mA	
Threshold input values	At 1	Voltage	≥ 10 V (sink) or ≤ -10 V (source)
		Current	≥ 2 mA
	At 0	Voltage	≤ 5 V (sink) or ≥ -5 V (source)
		Current	≤ 1.5 mA
	Sensor supply (including ripple for standard module)		19...30 V
	Input impedance	At nominal U	7.27 k Ω
Response time	Typical	4 ms	
	Maximum	7 ms	
Reliability	MTBF in hours at ambient temperature 30 °C (86 °F)	700 785	
Reverse polarity		Protected	
Fuse type	Internal	None	
	External	1 fast blow fuse of 0.5 A	

Input type		Current sink/source
IEC 61131-2 compliance (24 VDC input)		Type 3
IEC 61131-2 compliance (12 VDC input)		—
2-wire / 3-wire proximity sensor compatibility (IEC 60947-5-2 standard compliant)		2-wire (DC), and 3-wire (DC), page 87
Dielectric strength	Primary/Secondary	1500 V actual, 50 / 60 Hz for 1 min.
	Between channel groups	1500 V actual, 50 / 60 Hz for 1 min.
Resistance of insulation		>10 MΩ (below 500 VDC)
Paralleling of inputs⁽¹⁾		Yes
Sensor voltage: monitoring threshold	OK	> 19VDC
	Error	< 14 VDC
Sensor voltage: monitoring response time at 24 V (-15% ... +20%)	On appearance	1 ms < T < 3 ms
	On disappearance	8 ms < T < 30 ms
Power consumption 3.3 V	Typical	100 mA
	Maximum	130 mA
Power consumption 24 V	Typical	7.6mA
	Maximum	11.5 mA
Sensor supply consumption⁽²⁾	Typical	110 mA
	Maximum	125 mA
Power dissipation		4.7 W max.
Temperature derating for BMX DDI 3203		None
(1) This characteristic is used to connect several inputs to the same module in parallel or to different modules for input redundancy.		

NOTE: The power monitoring is effective only when the group input shares the same power supply. The module is able to customize sink/source by channel in case the power supply monitor function is disabled. Refer to the topic , page 135for additional information about usage of the power monitoring function and power supply connections.

NOTE: Confirm that the sensor power supply function is disabled in a 12 VDC application.

Connecting the Module

At a Glance

The BMX DDI 3232 is fitted with a removable 40-pin terminal block for the connection of thirty-two input channels.

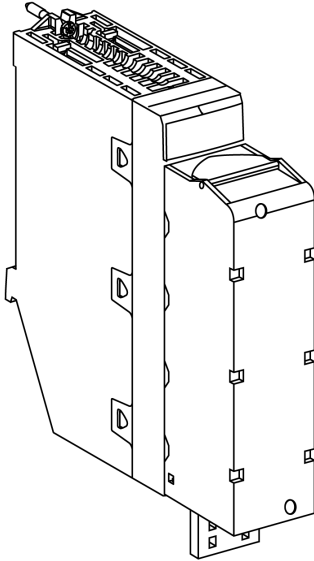

Input Circuit Diagram

The following diagram shows the circuit of a direct current input (positive logic).

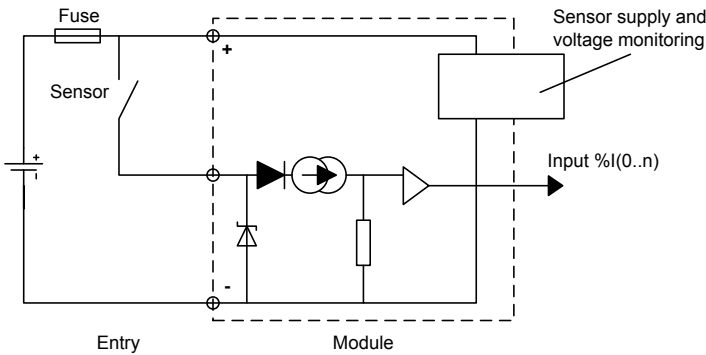

The following diagram shows the circuit of a direct current input (negative logic).

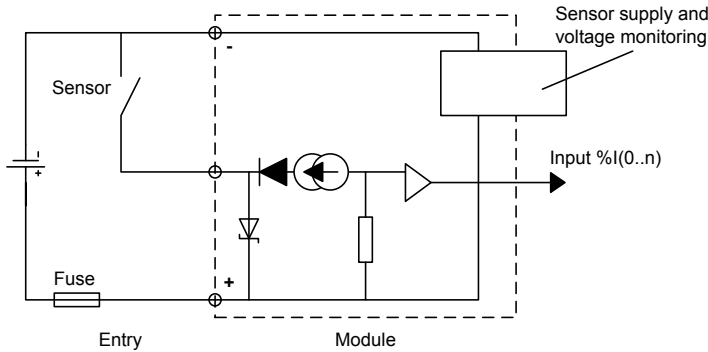

Module Connection

⚡⚠ DANGER

HAZARD OF ELECTRICAL SHOCK, EXPLOSION OR ARC FLASH

Switch off the sensor and pre-actuator voltages before connecting or disconnecting the module.

Failure to follow these instructions will result in death or serious injury.

⚠ WARNING

EQUIPMENT DAMAGE

- Do not connect SPS A/B terminal to more than one power supply.
- In case of multiple power supplies in the same group of channels, disconnect SPS A/B terminal and disable the power supply monitoring function.

Failure to follow these instructions can result in death, serious injury, or equipment damage.

⚠ CAUTION

LOSS OF INPUT FUNCTION

Install the correct type of fuse with the correct rating.

Failure to follow these instructions can result in injury or equipment damage.

The following diagrams show the connection of the module to the sensors:

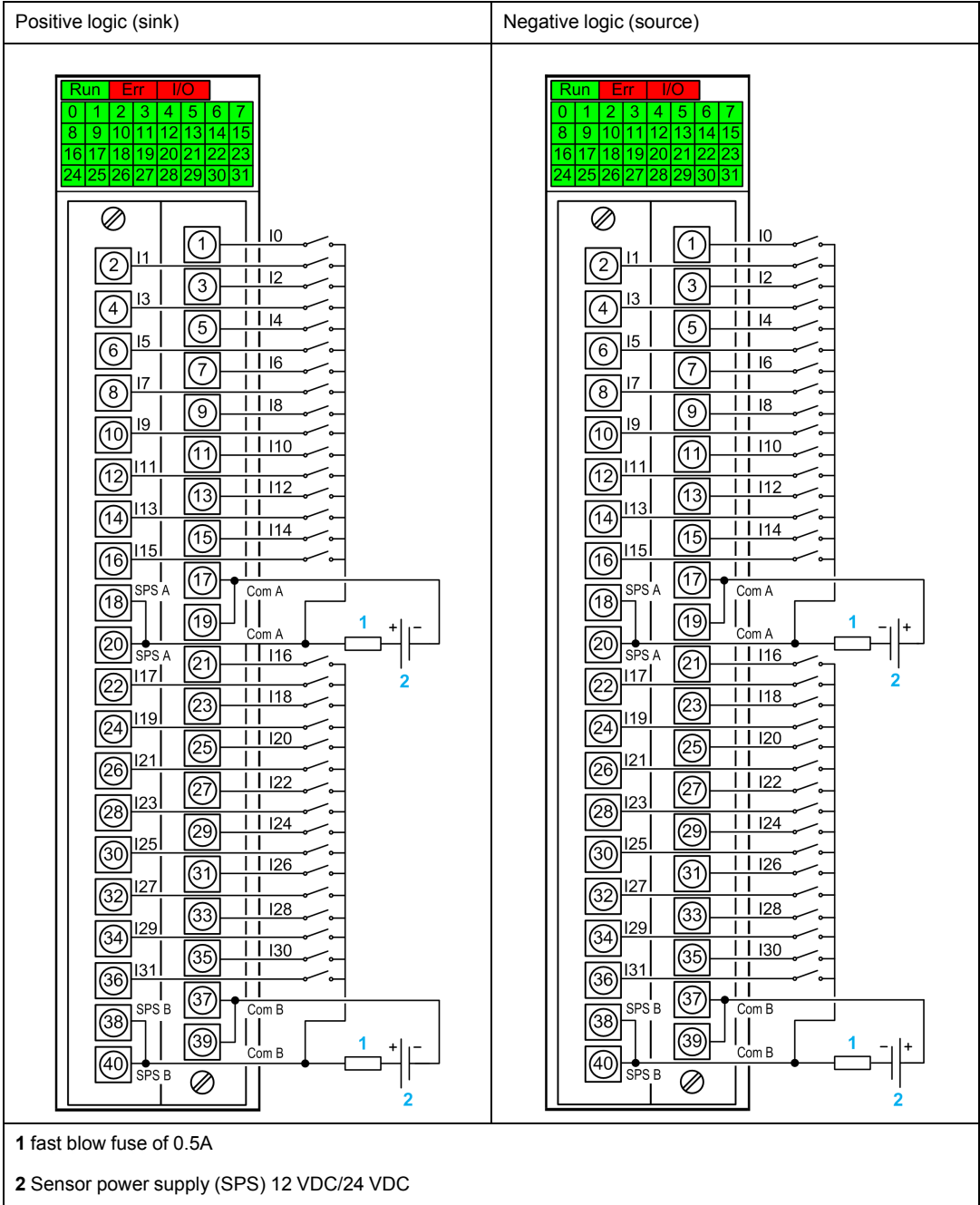

The following diagram shows an example of mixed sink/source input:

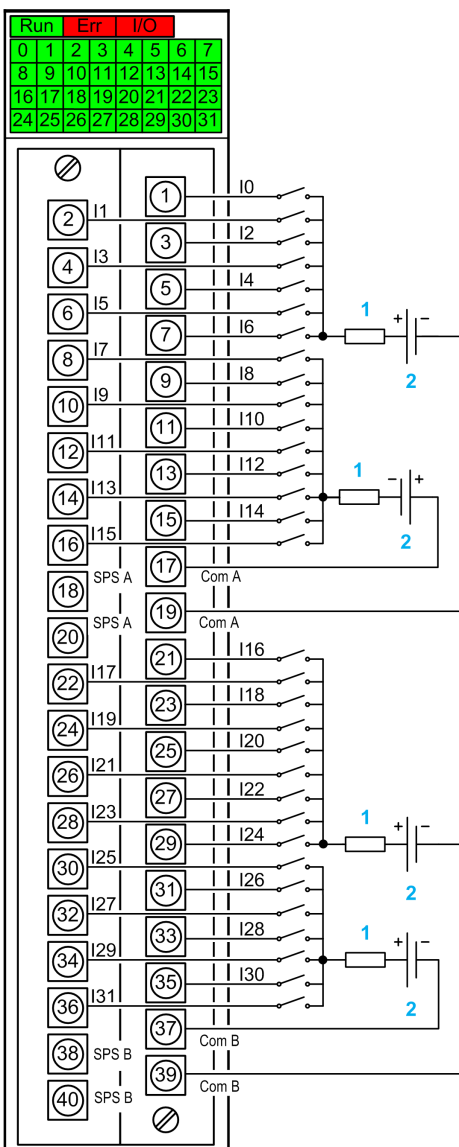

1 fast blow fuse of 0.5A

2 Sensor power supply (SPS) 12 VDC/24 VDC

NOTE: In the above example, inputs of group A are in positive or negative logic (sink or source), whereas inputs of group B are only in positive logic (sink). *SPS A* and *SPS B* terminals are not connected and power supply monitoring should be disabled for both groups.

Sensor Power Outage

After a power sensor outage, if the **Supply monitoring** check box is not selected in the module configuration screen then the digital input can stay active.

WARNING

DIGITAL INPUT STATE INACTIVE AFTER A SENSOR POWER OUTAGE

Do not click to clear the **Supply monitoring** check box in the module configuration screen to guarantee the digital input state inactive after sensor power outage.

Failure to follow these instructions can result in death, serious injury, or equipment damage.

To access the **Supply monitoring** check box, refer to chapter *How to Modify the External Power Supply Error Monitoring Parameter*, page 351.

After the sensor power outage, the I/O (red) LED of the module switches on and the last recorded position of the sensor is displayed by the input channel status LED's.

WARNING

CHANNEL LED INFORMATION NOT MATCHING SENSORS POSITION

After a sensor power outage:

- The I/O error LED is on
- Do not take into account the input LEDs information (they show the last recorded position of the sensors, not their real positions)
- Check the real positions on the sensors.

Failure to follow these instructions can result in death, serious injury, or equipment damage.

BMX DAI 1602 Input Modules

What's in This Chapter

Introduction	139
Characteristics.....	140
Connecting the Module	142

Subject of this Section

This section presents the BMX DAI 1602 module, its characteristics, and explains how it is connected to the various sensors.

Introduction

Function

The BMX DAI 1602 module is a 24 VAC discrete module connected via a 20-pin terminal block. This module has 16 input channels that operate on alternating current.

This module can also be used with 24 VDC, with positive or negative logic.

Ruggedized Version

The BMX DAI 1602H (hardened) equipment is the ruggedized version of the BMX DAI 1602 (standard) equipment. It can be used at extended temperatures and in harsh chemical environments.

For more information, refer to chapter *Installation in More Severe Environments* (see Modicon M580, M340, and X80 I/O Platforms, Standards and Certifications).

Illustration

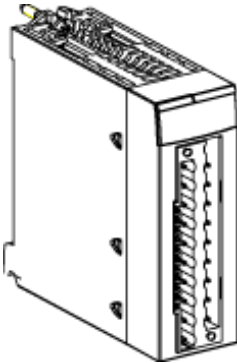

Characteristics

Altitude Operating Conditions

The characteristics in the table below apply to the modules BMX DAI 1602 and BMX DAI 1602H for use at altitude up to 2000 m (6560 ft). When the modules operate above 2000 m (6560 ft), apply additional derating.

For detailed information, refer to chapter *Operating and Storage Conditions* (see Modicon M580, M340, and X80 I/O Platforms, Standards and Certifications).

General Characteristics

This table presents the general characteristics for the BMX DAI 1602 and BMX DAI 1602H modules:

BMX DAI 1602(H) Module		24 VAC inputs	24 VDC inputs
Nominal input values		Voltage	24 VAC
		Current	3 mA
		Frequency	50/60Hz
Threshold input values	At 1	Voltage	≥ 15 V
		Current	≥ 2 mA
	At 0	Voltage	≤ 5 V
		Current	≤ 1 mA
	Frequency		47 Hz to 63 Hz

BMX DAI 1602(H) Module		24 VAC inputs	24 VDC inputs
	Sensor supply (including ripple)	20...26 V	19...30 V
	Peak of current on enabling (at nominal U)	5 mA	(n/a)
Input impedance	At nominal U and f = 55 Hz	6 kΩ	
Response time	Activation	15 ms	
	Deactivation	20 ms	
Input type		Resistive	
Input type in compliance with IEC 61131-2 standard		Type 1	(n/a)
2-wire / 3-wire proximity sensor compatibility (IEC 60947-5-2 standard compliant)		2-wire (AC), page 87	2-wire (DC), and 3-wire (DC) PNP any type, page 87
Reliability	MTBF for continuous operation in hours at ambient temperature 30 °C (86 °F)	1 307 702	
Dielectric strength		1500 V actual, 50 / 60 Hz for 1 min.	
Resistance of insulation		>10 MΩ (below 500 VDC)	
Fuse type	Internal	None	
	External	Fast blow fuse of 0.5 A	
Sensor voltage: monitoring threshold	OK	> 18 V	
	Error	< 14 V	
Sensor voltage: monitoring response time at 24 V (-15% ... +20%)	On appearance	20 ms < T < 50 ms	
	On disappearance	5 ms < T < 15 ms	
Power consumption 3.3 V	Typical	76 mA	
	Maximum	107 mA	
Sensor supply consumption	Typical	1.45 mA	
	Maximum	1.8 mA	
Power dissipation		3 W max.	
Operating temperature	BMX DAI 1602	0...60 °C (32...140 °F)	
	BMX DAI 1602H	-25...70 °C (-13...158 °F)	

Connecting the Module

At a Glance

The BMX DAI 1602 module is fitted with a removable 20-pin terminal block for the connection of sixteen input channels.

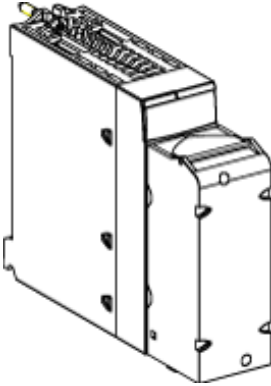

Input Circuit Diagram

The following diagram shows the circuit of an alternating current input.

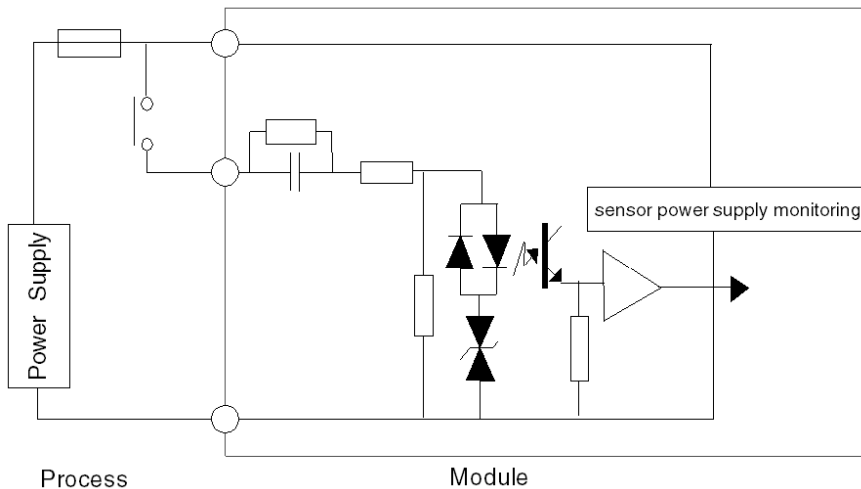

Module Connection (AC Power Supply)

DANGER

HAZARD OF ELECTRICAL SHOCK, EXPLOSION OR ARC FLASH

Switch off the sensor and pre-actuator voltage before connecting or disconnecting the module.

Failure to follow these instructions will result in death or serious injury.

CAUTION

LOSS OF OUTPUT FUNCTION

Install the correct rating and type of fuse.

Failure to follow these instructions can result in injury or equipment damage.

The following diagram shows the connection of the module to the sensors, using an AC power supply.

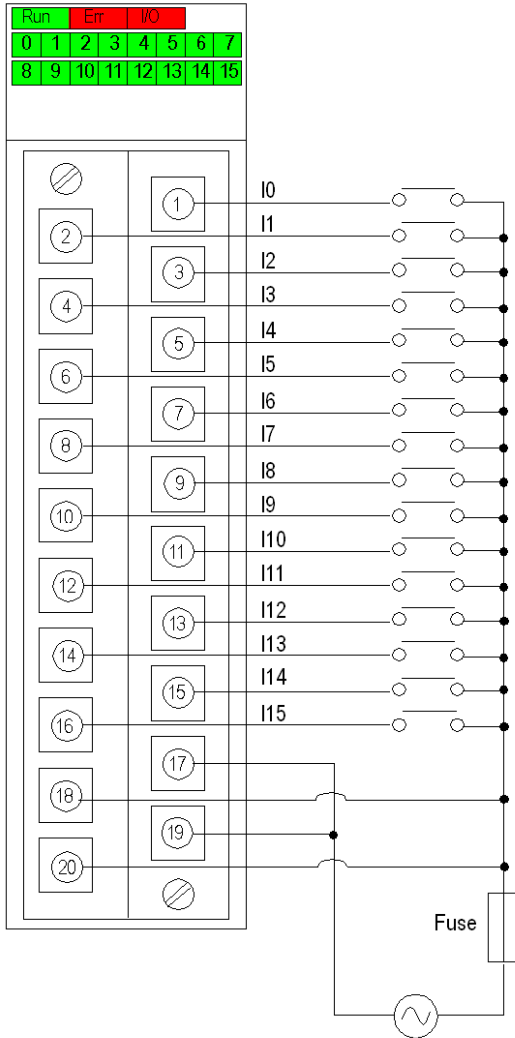

power supply: 24 VAC

fuse: fast blow fuse of 0.5A

Module Connection (DC Power Supply)

This module can also be used with 24 VDC, with positive or negative logic.

DANGER

HAZARD OF ELECTRICAL SHOCK, EXPLOSION OR ARC FLASH

Switch off the sensor and pre-actuator voltage before connecting or disconnecting the module.

Failure to follow these instructions will result in death or serious injury.

CAUTION

LOSS OF OUTPUT FUNCTION

Install the correct rating and type of fuse.

Failure to follow these instructions can result in injury or equipment damage.

The following diagram shows the connection of the module to the sensors, using a DC power supply.

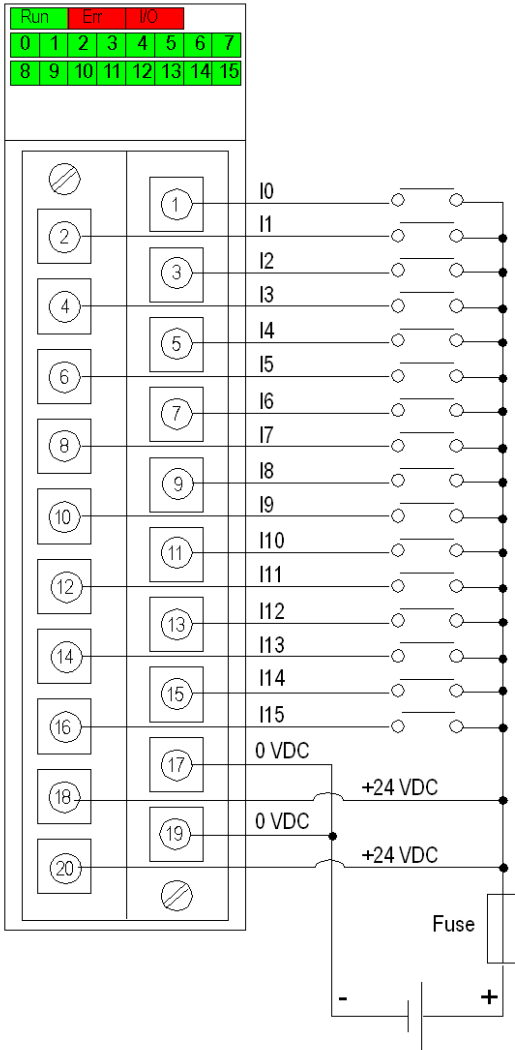

Positive Logic Wiring

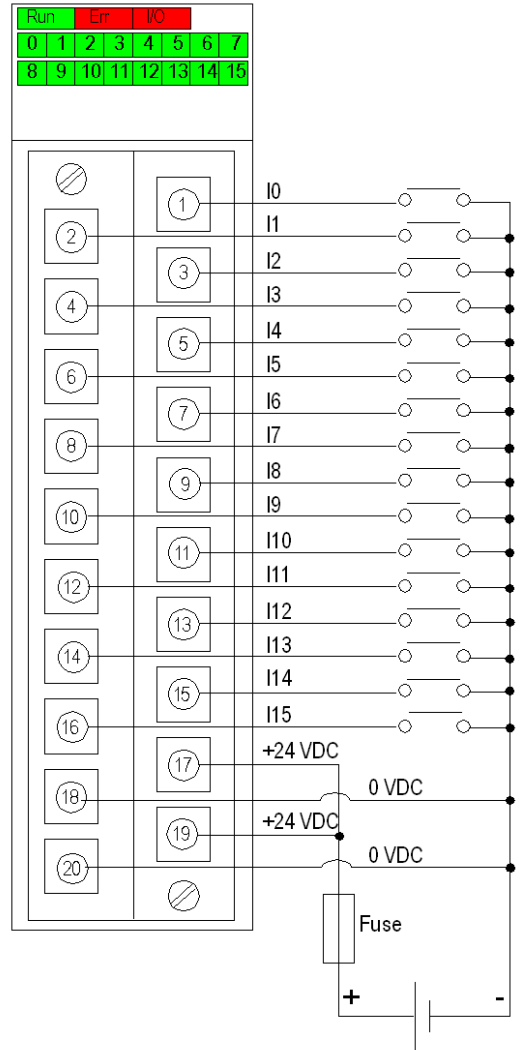

Negative Logic Wiring

power supply: 24 VDC

fuse: fast blow fuse of 0.5A

BMX DAI 1603 Input Modules

What's in This Chapter

Introduction	147
Characteristics.....	148
Connecting the Module	150

Subject of this Section

This section presents the BMX DAI 1603 module, its characteristics, and explains how it is connected to the various sensors.

Introduction

Function

The BMX DAI 1603 module is a 48 VAC discrete module connected via a 20-pin terminal block. This module has 16 input channels that operate on alternating current.

Ruggedized Version

The BMX DAI 1603H (hardened) equipment is the ruggedized version of the BMX DAI 1603 (standard) equipment. It can be used at extended temperatures and in harsh chemical environments.

For more information, refer to chapter *Installation in More Severe Environments* (see Modicon M580, M340, and X80 I/O Platforms, Standards and Certifications).

Illustration

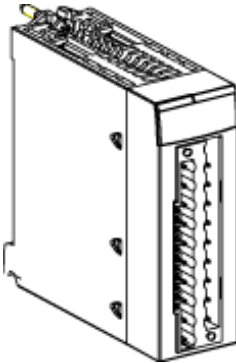

Characteristics

Altitude Operating Conditions

The characteristics in the table below apply to the modules BMX DAI 1603 and BMX DAI 1603H for use at altitude up to 2000 m (6560 ft). When the modules operate above 2000 m (6560 ft), apply additional derating.

For detailed information, refer to chapter *Operating and Storage Conditions* (see Modicon M580, M340, and X80 I/O Platforms, Standards and Certifications).

General Characteristics

This table presents the general characteristics for the BMX DAI 1603 and BMX DAI 1603H modules:

Module type		48 VAC inputs	
Operating temperature	BMX DAI 1603	0...60 °C (32...140 °F)	
	BMX DAI 1603H	-25...70 °C (-13...158 °F)	
Nominal input values		Voltage	48 VAC
		Current	5 mA
		Frequency	50/60Hz
Threshold input values	At 1	Voltage	≥ 34 V
		Current	≥ 2 mA
	At 0	Voltage	≤ 10 V

	Current	≤ 1 mA
	Frequency	47 Hz to 63 Hz
	Sensor supply (including ripple)	40...52 V
	Peak of current on enabling (at nominal U)	95 mA
Input impedance	At nominal U and f = 55 Hz	9 kΩ
Response time	Activation	10 ms
	Deactivation	20 ms
Input type		Capacitive
Input type in compliance with IEC 61131-2 standard		Type 3
2-wire / 3-wire proximity sensor compatibility (IEC 60947-5-2 standard compliant)		2-wire (AC), page 87
Reliability	MTBF for continuous operation in hours at ambient temperature 30 °C (86 °F)	1 303 645
Dielectric strength		1500 V actual, 50 / 60 Hz for 1 min.
Resistance of insulation		>10 MΩ (below 500 VDC)
Fuse type	Internal	None
	External	Fast blow fuse of 0.5 A
Sensor voltage: monitoring threshold	OK	> 36 V
	Error	< 24 V
Sensor voltage: monitoring response time at 24 V (-15% ... +20%)	On appearance	20 ms < T < 50 ms
	On disappearance	5 ms < T < 15 ms
Power consumption 3.3 V	Typical	76 mA
	Maximum	107 mA
Sensor supply consumption	Typical	466 mA
	Maximum	846 mA
Power dissipation		4 W max.

Connecting the Module

At a Glance

The BMX DAI 1603 module is fitted with a removable 20-pin terminal block for the connection of sixteen input channels.

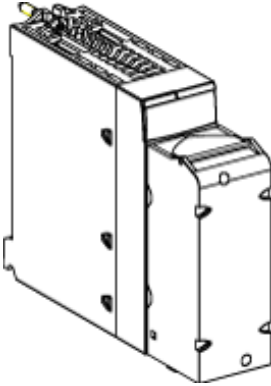

Input Circuit Diagram

The following diagram shows the circuit of an alternating current input.

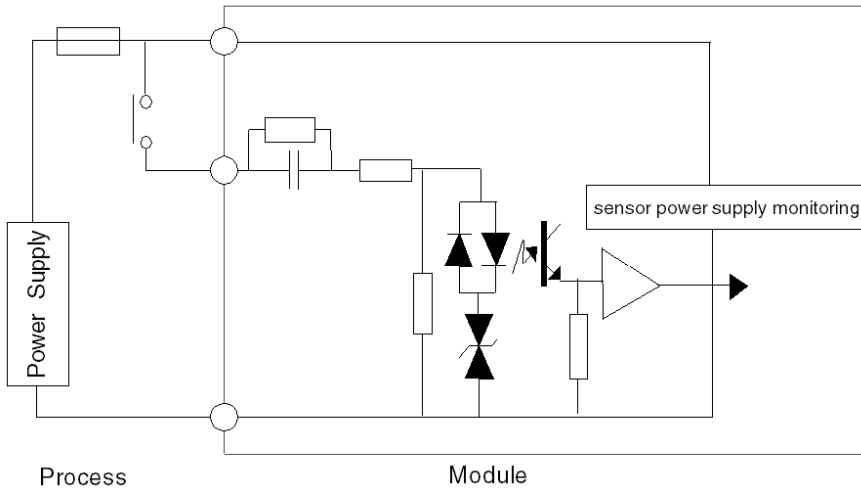

Module Connection

DANGER

HAZARD OF ELECTRICAL SHOCK, EXPLOSION OR ARC FLASH

Switch off the sensor and pre-actuator voltages before connecting or disconnecting the module.

Failure to follow these instructions will result in death or serious injury.

CAUTION

LOSS OF INPUT FUNCTION

Install the correct type of fuse with the correct rating.

Failure to follow these instructions can result in injury or equipment damage.

The following diagram shows the connection of the module to the sensors.

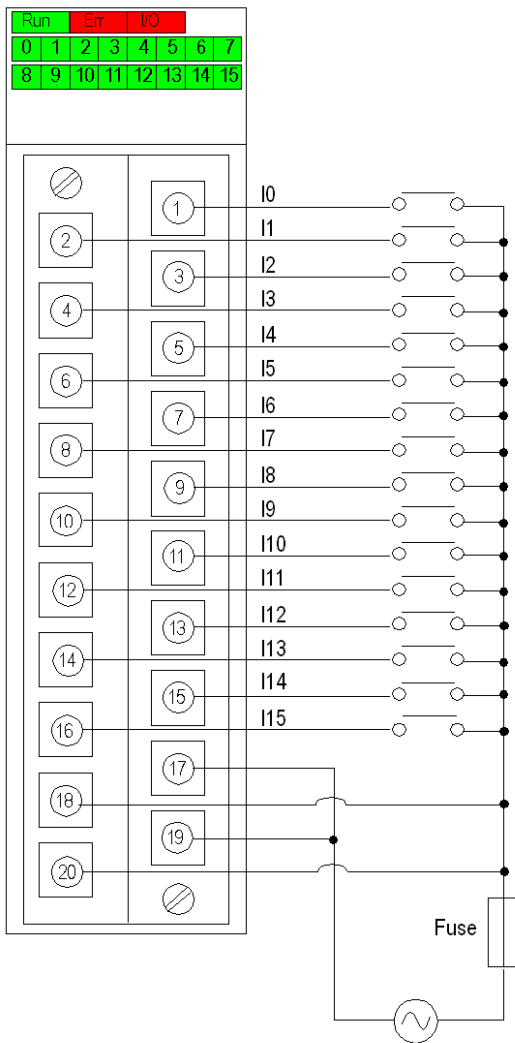

power supply: 48 VAC

fuse: fast blow fuse of 0.5A

BMX DAI 1604 Input Modules

What's in This Chapter

Introduction	153
Characteristics.....	154
Connecting the Module	156

Subject of this Section

This section presents the BMX DAI 1604 module, its characteristics, and explains how it is connected to the various sensors.

Introduction

Function

The BMX DAI 1604 module is a 100...120 VAC discrete module connected via a 20-pin terminal block. This module has 16 input channels that operate on alternating current.

Ruggedized Version

The BMX DAI 1604H (hardened) equipment is the ruggedized version of the BMX DAI 1604 (standard) equipment. It can be used at extended temperatures and in harsh chemical environments.

For more information, refer to chapter *Installation in More Severe Environments* (see Modicon M580, M340, and X80 I/O Platforms, Standards and Certifications).

Illustration

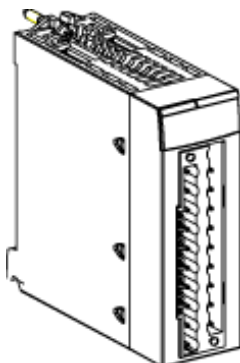

Characteristics

Altitude Operating Conditions

The characteristics in the table below apply to the modules BMX DAO 1604 and BMX DAO 1604H for use at altitude up to 2000 m (6560 ft). When the modules operate above 2000 m (6560 ft), apply additional derating.

For detailed information, refer to chapter *Operating and Storage Conditions* (see Modicon M580, M340, and X80 I/O Platforms, Standards and Certifications).

General Characteristics

This table presents the general characteristics for the BMX DAO 1604 and BMX DAO 1604H modules:

Module type		100...120 VAC inputs	
Operating temperature	BMX DAI 1604	0...60 °C (32...140 °F)	
	BMX DAI 1604H	-25...70 °C (-13...158 °F)	
Nominal input values		Voltage	100...120 VAC
		Current	5 mA
		Frequency	50/60Hz
Threshold input values	At 1	Voltage	≥ 74 V
		Current	≥ 2.5 mA
	At 0	Voltage	≤ 20 V

	Current	≤ 1 mA
	Frequency	47 Hz to 63 Hz
	Sensor supply (including ripple)	85...132 V
	Peak of current on enabling (at nominal U)	240 mA
Input impedance	at nominal U and f = 55 Hz	13 kΩ
Response time	Activation	10 ms
	Deactivation	20 ms
Input type		Capacitive
Input type in compliance with IEC 61131-2 standard		Type 3
2-wire / 3-wire proximity sensor compatibility (IEC 60947-5-2 standard compliant)		2-wire (AC), page 87
Reliability	MTBF for continuous operation in hours at ambient temperature 30 °C (86 °F)	1 303 067
Dielectric strength		1500 V actual, 50 / 60 Hz for 1 min.
Resistance of insulation		>10 MΩ (below 500 VDC)
Fuse type	Internal	None
	External	Fast blow fuse of 0.5 A
Sensor voltage: monitoring threshold	OK	> 82 V
	Error	< 40 V
Sensor voltage: monitoring response time at 24 V (-15% ... +20%)	on appearance	20 ms < T < 50 ms
	on disappearance	5 ms < T < 15 ms
Power consumption 3.3 V	typical	76 mA
	maximum	107 mA
Sensor supply consumption	typical	228 mA
	maximum	510 mA
Power dissipation		3.8 W max.

Connecting the Module

At a Glance

The BMX DAI 1604 module is fitted with a removable 20-pin terminal block for the connection of sixteen input channels.

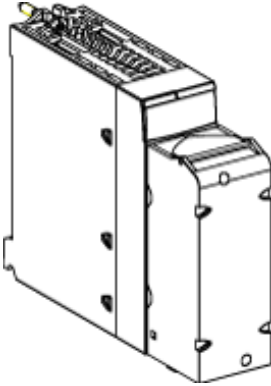

Input Circuit Diagram

The following diagram shows the circuit of an alternating current input.

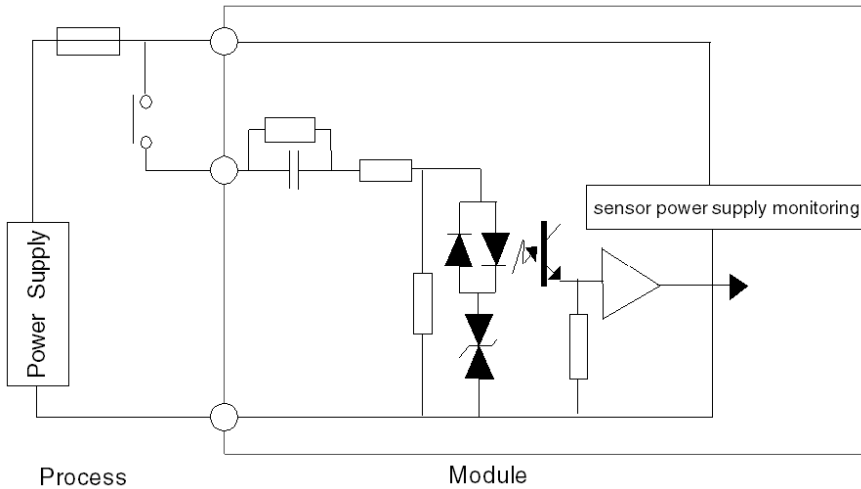

Module Connection

DANGER

HAZARD OF ELECTRICAL SHOCK, EXPLOSION OR ARC FLASH

Switch off the sensor and pre-actuator voltages before connecting or disconnecting the module.

Failure to follow these instructions will result in death or serious injury.

CAUTION

LOSS OF INPUT FUNCTION

Install the correct type of fuse with the correct rating.

Failure to follow these instructions can result in injury or equipment damage.

The following diagram shows the connection of the module to the sensors.

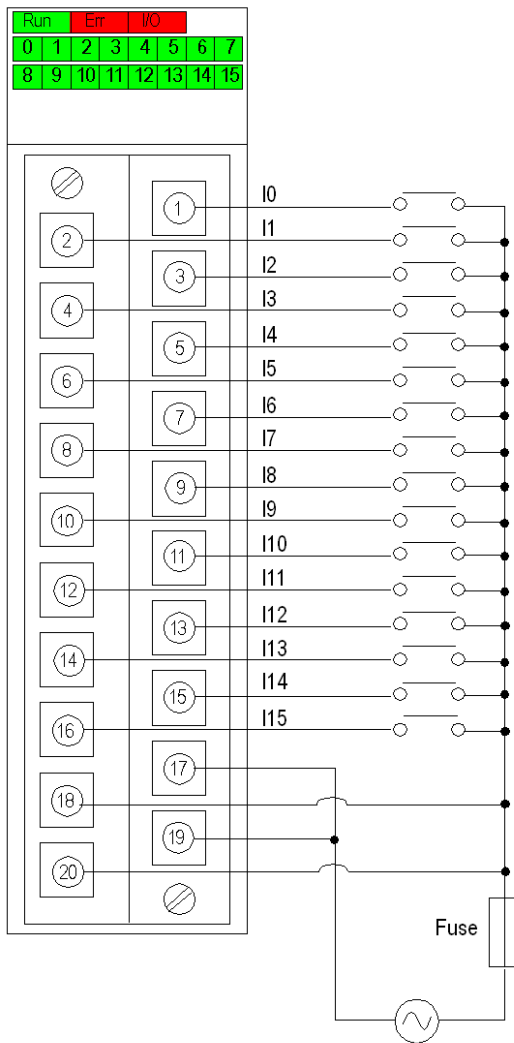

power supply: 100...120 VAC

fuse: fast blow fuse of 0.5A

BMX DAI 1614 / BMX DAI 16142 Input Modules

What's in This Chapter

Introduction	159
Characteristics.....	160
Connecting the Module	164

Subject of this Section

This section presents the BMX DAI 1614 and BMX DAI 16142 module, their characteristics, and explains how they are connected to the various sensors.

Introduction

Function of the BMX DAI 1614 Module

The BMX DAI 1614 module is a 100...120 VAC discrete module connected via a 40-pin terminal block. This module has 16 input isolated channels that operate on alternating current.

NOTE: Using the BMX DAI 1614 module in an X80 remote drop requires to use an adapter module BM•CRA 312•• module with firmware version SV2.31 or higher.

Function of the BMX DAI 16142 Module

The BMX DAI 16142 module is a fine-tuned version of BMX DAI 1614 but with most of its features. BMX DAI 16142 is at the same threshold level as the existing Quantum modules at 60 Hz 100...120 VAC, which is intended to cover the upgrade need of Quantum installed base.

Ruggedized Version

The BMX DAI 1614H (hardened) equipment is the ruggedized version of the BMX DAI 1614 (standard) equipment. It can be used at extended temperatures and in harsh chemical environments.

For more information, refer to chapter *Installation in More Severe Environments* (see Modicon M580, M340, and X80 I/O Platforms, Standards and Certifications).

Illustration

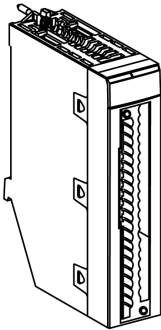

Characteristics

Altitude Operating Conditions

The characteristics in the table below apply to the modules BMX DAI 1614, BMX DAI 1614H, and BMX DAI 16142 for use at altitude up to 2000 m (6560 ft). When the modules operate above 2000 m (6560 ft), apply additional derating.

For detailed information, refer to chapter *Operating and Storage Conditions* (see Modicon M580, M340, and X80 I/O Platforms, Standards and Certifications).

General Characteristics

This table presents the general characteristics for the BMX DAI 1614 and BMX DAI 1614H modules:

Module type			100...120 VAC inputs
Operating temperature	BMX DAI 1614		0...60 °C (32...140 °F)
	BMX DAI 1614H		-25...70 °C (-13...158 °F)
Nominal input values	Voltage		100...120 VAC
	Current		10.1 mA (max) @ 47...53 Hz 11.9 mA (max) @ 57...63 Hz
	Frequency		50/60Hz
Threshold input values	At 1	Voltage	≥ 79 V
		Current	≥ 2 mA

	At 0	Voltage	≤ 20 V
		Current	≤ 1 mA
	Frequency		47...63 Hz
	Peak of current on enabling (at nominal U)		190 mA
Max channel input voltage			132 Vrms @ 63 Hz
Input impedance	at nominal U and f = 55 Hz		14 kΩ
Response time	Activation		10 ms
	Deactivation		20 ms
Input type			Capacitive
Input type in compliance with IEC 61131-2 standard			Type 1
2-wire / 3-wire proximity sensor compatibility (IEC 60947-5-2 standard compliant)			2-wire (AC), page 87
Reliability	MTBF for continuous operation in hours at ambient temperature 30 °C (86 °F)		970 000
Fuse type	Internal		None
	External		Fast blow fuse of 0.25 A
Dielectric strength	Channel to X-bus		1780 V actual, 50 / 60 Hz for 1 min.
	Channel to channel		1780 V actual, 50 / 60 Hz for 1 min.
Resistance of insulation	Channel to X-bus		>10 MΩ (below 500 VDC)
	Channel to channel		>10 MΩ (below 500 VDC)
Sensor voltage: monitoring threshold	OK		> 85 V
	Error		< 40 V
Sensor voltage: monitoring response time at 24 V (-15% ... +20%)	on appearance		20 ms < T < 50 ms
	on disappearance		5 ms < T < 15 ms
Power consumption 3.3 V	typical		76 mA
	maximum		126 mA
Open wire detection: current threshold	Ok		> 0.3 mA
	Error		< 0.2 mA

Open wire shunt resistor recommendation NOTE: The external shunt resistor is only required when the leakage current of the sensor (at OFF state) is less than 0.3 mA. Detailed resistor calculation is provided in the section <i>Open Wire Detection Function</i> , page 167.	200 k Ω (1W)
Power dissipation	4.3 W max.

This table presents the general characteristics for the BMX DAI 16142 module:

Module type		100...120 VAC inputs	
Operating temperature	BMX DAI 16142	0...60 °C (32...140 °F)	
Nominal input values	Voltage	100...120 VAC	
	Current	10.1 mA (max) @ 47...53 Hz 11.9 mA (max) @ 57...63 Hz	
	Frequency	50/60Hz	
Threshold input values	At 1	Voltage	≥ 85 V @ 47...53 Hz ≥ 70 V @ 57...63 Hz
		Current	≥ 4 mA
	At 0	Voltage	≤ 55 V @ 47...53 Hz ≤ 48 V @ 57...63 Hz
		Current	≤ 3 mA
	Frequency	47...63 Hz	
	Peak of current on enabling (at nominal U)	190 mA	
Max channel input voltage		132 Vrms @ 63 Hz	
Input impedance	at nominal U	13.0 to 16.2 k Ω @ 47...53 Hz 11.0 to 13.4 k Ω @ 57...63 Hz	
Response time	Activation	10 ms	
	Deactivation	20 ms	
Input type		Capacitive	
Input type in compliance with IEC 61131-2 standard		No type @ 47...53 Hz Type 1 @ 57...63 Hz	
2-wire / 3-wire proximity sensor compatibility (IEC 60947-5-2 standard compliant)		2-wire (AC), page 87	

Reliability	MTBF for continuous operation in hours at ambient temperature 30 °C (86 °F)	970 000
Fuse type	Internal	None
	External	Fast blow fuse of 0.25 A
Dielectric strength	Channel to X-bus	1780 V actual, 50 / 60 Hz for 1 min.
	Channel to channel	1780 V actual, 50 / 60 Hz for 1 min.
Resistance of insulation	Channel to X-bus	> 10 MΩ (below 500 VDC)
	Channel to channel	> 10 MΩ (below 500 VDC)
Sensor voltage: monitoring threshold	OK	> 98 V @ 47...53 Hz > 85 V @ 57...63 Hz
	Error	< 40 V
Sensor voltage: monitoring response time at 24 V (-15% ... +20%)	on appearance	20 ms < T < 50 ms
	on disappearance	5 ms < T < 15 ms
Power consumption 3.3 V	typical	76 mA
	maximum	126 mA
Open wire detection: current threshold	Ok	> 0.3 mA
	Error	< 0.2 mA
Open wire shunt resistor recommendation NOTE: The external shunt resistor is only required when the leakage current of the sensor (at OFF state) is less than 0.3 mA. Detailed resistor calculation is provided in the section <i>Open Wire Detection Function</i> , page 167.		200 KΩ (1W)
Power dissipation		4.3 W max.

Connecting the Module

At a Glance

The BMX DAI 1614 and BMX DAI 16142 modules are fitted with a removable 40-pin terminal block for the connection of 16 input channels.

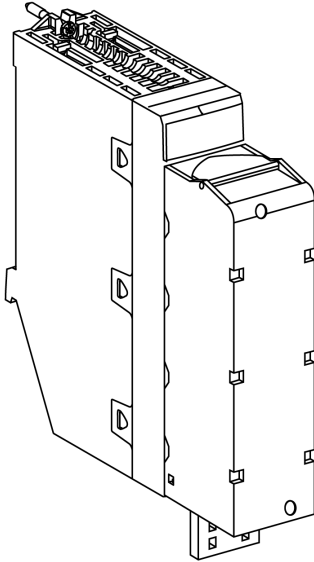

Input Circuit Diagram

The following diagram shows the circuit of an alternating current input.

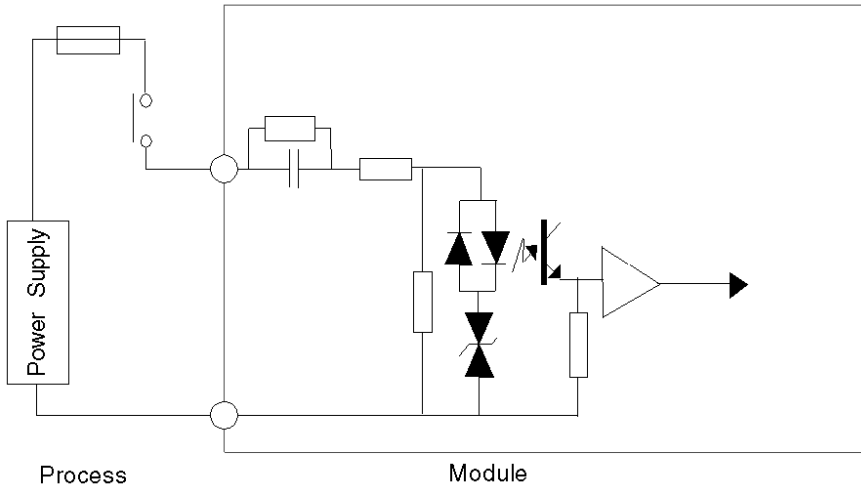

Module Connection

⚡ ⚠ DANGER

HAZARD OF ELECTRICAL SHOCK, EXPLOSION OR ARC FLASH

- Switch off the sensor and pre-actuator voltages before connecting or disconnecting the module.
- Switch off the sensor and pre-actuator voltages before touching the shunt resistor for open wire detection.

Failure to follow these instructions will result in death or serious injury.

⚠ CAUTION

LOSS OF INPUT FUNCTION

Install the correct type of fuse with the correct rating.

Failure to follow these instructions can result in injury or equipment damage.

The following diagram shows the connection of the sensors to the module.

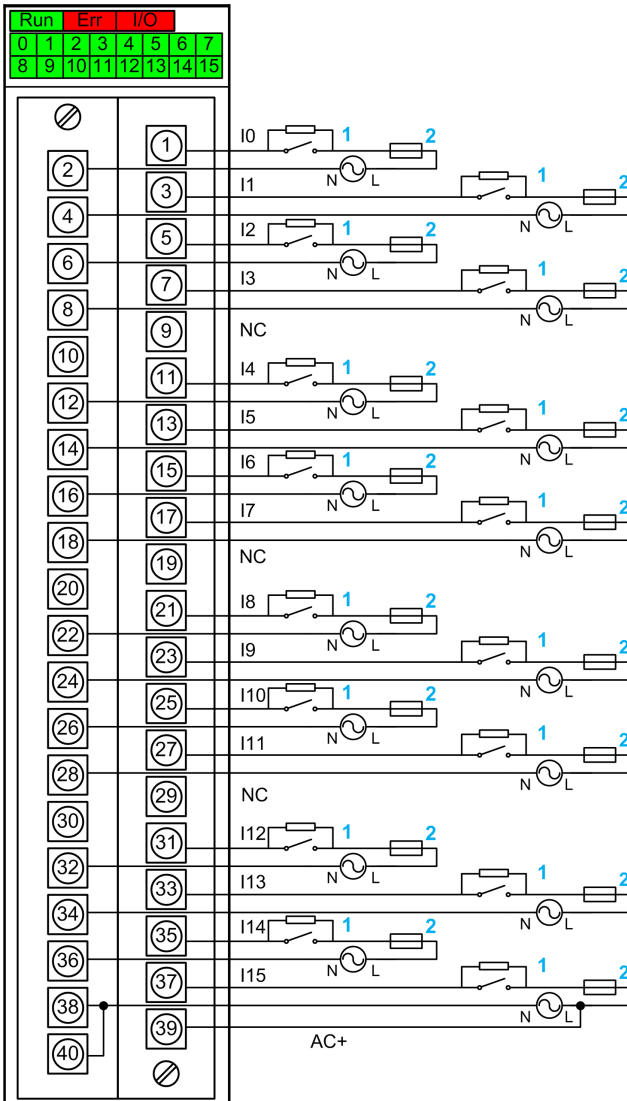

1 External resistor for open wire detection function (see detail below)

2 fast blow fuse of 0.25A

AC+ Input pin for IO supply monitoring function on channel 15 (see detail below)

NC not connected

Power supply: 100...120 Vac

NOTE: The maximum input voltage is 132 Vrms@63 Hz. Any over voltage will damage the module.

Open Wire Detection Function

The open wire detection function indicates the open wire error by detecting the leakage current of the sensor. The detection threshold values are given in the general characteristics table, page 160.

If the leakage current of the sensor (at OFF state) is less than the OK threshold value (0.3 mA), then the open wire error might be reported even if the wire is not open. In order to avoid this, an external resistor is required to be added in parallel with the sensor. Refer to the module connection, page 165.

The recommended value for the external shunt resistor is 200 kΩ (1 W).

Anyhow the maximum and minimum allowed for the external resistor can be calculated according the following method:

$$R_{EXT_MAX} = \frac{U_{MIN}}{I_{DETECT_OK}} - Z_{DAI_MAX}$$

U_{MIN} is 85% of the nominal voltage according to IEC norm.

$$I_{DETECT_OK} = 0.3 \text{ mA}$$

$$Z_{DAI_MAX} = 17 \text{ k}\Omega \text{ (for 47 Hz) or } 14 \text{ k}\Omega \text{ (for 57 Hz)}$$

$$R_{EXT_MIN} = \frac{U_{MAX} - I_{THRESHOLD_OFF} \times Z_{DAI_MIN}}{I_{THRESHOLD_OFF} - I_{LEAKAGE_MAX}}$$

U_{MAX} is 110% of the nominal voltage according to the IEC norm.

$I_{THRESHOLD_OFF} = 1 \text{ mA}$ (this is the maximum threshold current for digital input channel at 0).

$$Z_{DAI_MIN} = 14 \text{ k}\Omega \text{ (for 53 Hz) or } 12 \text{ k}\Omega \text{ (for 63 Hz)}$$

$I_{LEAKAGE_MAX}$ is the maximum leakage current of the sensor at OFF state.

NOTE: Open wire detection limitations:

- If the external resistor value is greater than the maximum calculated resistance R_{EXT_MAX} , the open wire error might be reported even if the wire is not open.
- If the external resistor value is less than the minimum calculated resistance R_{EXT_MIN} , the corresponding digital input channel might see sensor state at 1 even if the sensor state is 0.
- If the supply monitoring function, page 168 is active and there is a loss of IO power supply, the open wire detection fault is not refreshed in Control Expert.

Supply Monitoring Function

The BMX DAI 1614 and BMX DAI 16142 modules are a channel-to-channel isolated module, 16 channels get 16 common pins.

The module terminal block has only one supply monitor input (AC+) and its common pin is shared with the channel 15.

To extend the supply monitoring function to other channels, the common of the channel 15 needs to be connected to the common pins of the other channels. In consequence the channel-to-channel isolation will be given up.

By default the supply monitoring function is inactive. Refer to the chapter *Configuration*, page 342 for detailed information.

The IO supply state is monitored as follows:

- When the IO supply is higher than 85 Vac, the EXT_PS_FLT bit is at 0 which means IO power supply is ok.
- When the IO supply is lower than 40 Vac, the EXT_PS_FLT bit is at 1 which means a detected error on IO power supply. All channel input values are forced to 0.

BMX DAI 1615 Input Modules

What's in This Chapter

Introduction	169
Characteristics.....	170
Connecting the Module	172

Subject of this Section

This section presents the BMX DAI 1615 module, its characteristics, and explains how it is connected to the various sensors.

Introduction

Function

The BMX DAI 1615 module is a 200...240 VAC discrete module connected via a 40-pin terminal block. This module has 16 isolated input channels that operate on alternating current.

NOTE: Using the BMX DAI 1615 module in an X80 remote drop requires to use an adapter module BM• CRA 312•• module with firmware version SV2.31 or higher.

Ruggedized Version

The BMX DAI 1615H (hardened) equipment is the ruggedized version of the BMX DAI 1615 (standard) equipment. It can be used at extended temperatures and in harsh chemical environments.

For more information, refer to chapter *Installation in More Severe Environments* (see Modicon M580, M340, and X80 I/O Platforms, Standards and Certifications).

Illustration

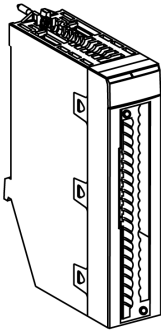

Characteristics

Altitude Operating Conditions

The characteristics in the table below apply to the modules BMX DAI 1615 and BMX DAI 1615H for use at altitude up to 2000 m (6560 ft). When the modules operate above 2000 m (6560 ft), apply additional derating.

For detailed information, refer to chapter *Operating and Storage Conditions* (see Modicon M580, M340, and X80 I/O Platforms, Standards and Certifications).

General Characteristics

This table presents the general characteristics for the BMX DAI 1615 and BMX DAI 1615H module:

Module type		200...240 VAC inputs	
Operating temperature	BMX DAI 1615	0...60 °C (32...140 °F)	
	BMX DAI 1615H	-25...70 °C (-13...158 °F)	
Nominal input values		Voltage	200...240 VAC
		Current	9.7 mA (max) @ 47...53 Hz 11.5 mA (max) @ 57...63 Hz
		Frequency	50/60Hz
Threshold input values	At 1	Voltage	≥ 164 V
		Current	≥ 3 mA

	At 0	Voltage	≤ 40 V
		Current	≤ 2 mA
	Frequency		47...63 Hz
	Peak of current on enabling (at nominal U)		380 mA
Input impedance	at nominal U and f = 55 Hz		30 kΩ
Max channel input voltage			264 Vrms @ 63 Hz
Response time	Activation		10 ms
	Deactivation		20 ms
Input type			Capacitive
Input type in compliance with IEC 61131-2 standard			Type 1
2-wire / 3-wire proximity sensor compatibility (IEC 60947-5-2 standard compliant)			2-wire (AC), page 87
Reliability	MTBF for continuous operation in hours at ambient temperature 30 °C (86 °F)		970 000
Fuse type	Internal		None
	External		Fast blow fuse of 0.25 A
Dielectric strength	Channel to X-bus		1780 V rms, 50 / 60 Hz for 1 min.
	Channel to channel		1780 V rms, 50 / 60 Hz for 1 min.
Resistance of insulation	Channel to X-bus		>10 MΩ (below 500 VDC)
	Channel to channel		>10 MΩ (below 500 VDC)
Sensor voltage: monitoring threshold	OK		> 170 V
	Error		< 80 V
Sensor voltage: monitoring response time	on appearance		20 ms < T < 50 ms
	on disappearance		5 ms < T < 15 ms
Power consumption 3.3 V	typical		76 mA
	maximum		126 mA
Open wire detection: current threshold	Ok		> 0.3 mA
	Erro		< 0.2 mA
Open wire shunt resistor recommendation NOTE: The external shunt resistor is only required when the leakage current of the sensor (at OFF state) is less than 0.3 mA. Detailed resistor calculation is provided in the section <i>Open Wire Detection Function</i> , page 175.			200 KΩ (1W)
Power dissipation			4.3 W max.

Connecting the Module

At a Glance

The BMX DAI 1615 module is fitted with a removable 40-pin terminal block for the connection of input channels.

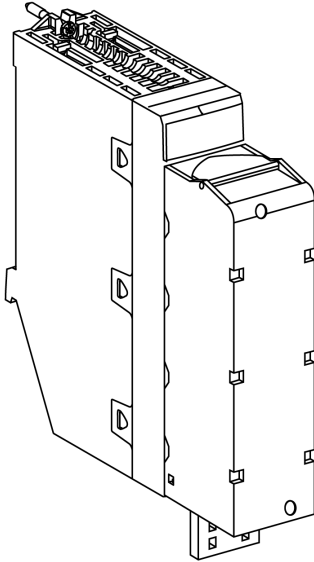

Input Circuit Diagram

The following diagram shows the circuit of an alternating current input.

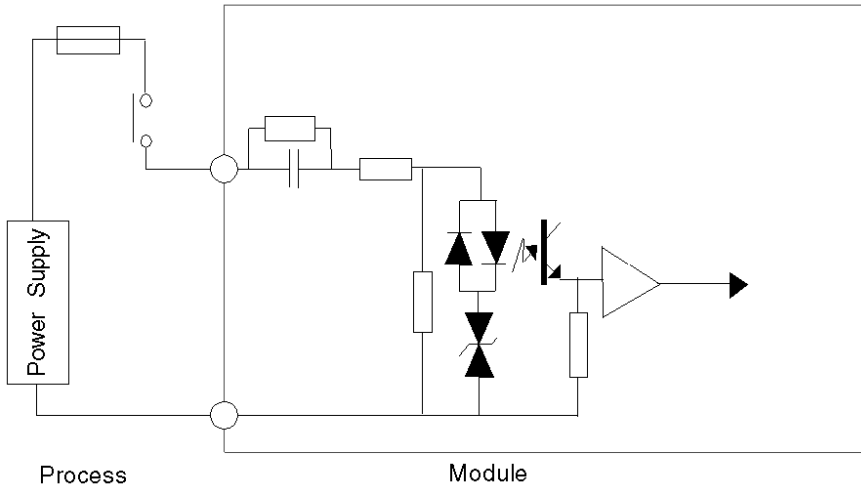

Module Connection

⚡ ⚠ DANGER

HAZARD OF ELECTRICAL SHOCK, EXPLOSION OR ARC FLASH

- Switch off the sensor and pre-actuator voltages before connecting or disconnecting the module.
- Switch off the sensor and pre-actuator voltages before touching the shunt resistor for open wire detection.

Failure to follow these instructions will result in death or serious injury.

⚠ CAUTION

LOSS OF INPUT FUNCTION

Install the correct type of fuse with the correct rating.

Failure to follow these instructions can result in injury or equipment damage.

The following diagram shows the connection of the sensors to the module.

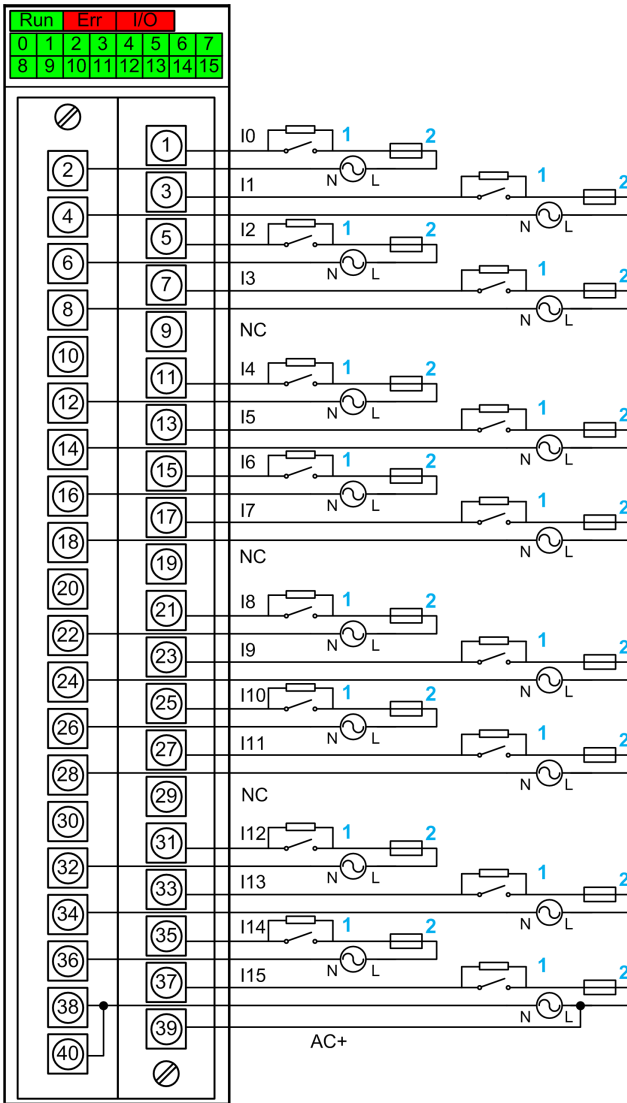

1 External resistor for open wire detection function (see detail below)

2 fast blow fuse of 0.5A

AC+ Input pin for IO supply monitoring function on channel 15 (see detail below)

NC not connected

Power supply: 220...240 Vac

NOTE: The maximum input voltage is 264 Vrms@63 Hz. Any over voltage will damage the module.

Open Wire Detection Function

The open wire detection function indicates the open wire error by detecting the leakage current of the sensor. The detection threshold values are given in the general characteristics table, page 170.

If the leakage current of the sensor (at OFF state) is less than the OK threshold value (0.3 mA), then the open wire error might be reported even if the wire is not open. In order to avoid this, an external resistor is required to be added in parallel with the sensor. Refer to the module connection, page 173.

The recommended value for the external shunt resistor is 200 kΩ (1 W).

Anyhow the maximum and minimum allowed for the external resistor can be calculated according the following method:

$$R_{EXT_MAX} = \frac{U_{MIN}}{I_{DETECT_OK}} - Z_{DAI_MAX}$$

U_{MIN} is 85% of the nominal voltage according to IEC norm.

$I_{DETECT_OK} = 0.3$ mA

$Z_{DAI_MAX} = 39$ kΩ (for 47 Hz) or 32 kΩ (for 57 Hz)

$$R_{EXT_MIN} = \frac{U_{MAX} - I_{THRESHOLD_OFF} \times Z_{DAI_MIN}}{I_{THRESHOLD_OFF} - I_{LEAKAGE_MAX}}$$

U_{MAX} is 110% of the nominal voltage according to the IEC norm.

$I_{THRESHOLD_OFF} = 2$ mA (this is the maximum threshold current for digital input channel at 0).

$Z_{DAI_MIN} = 28$ kΩ (for 53 Hz) or 24 kΩ (for 63 Hz)

$I_{LEAKAGE_MAX}$ is the maximum leakage current of the sensor at OFF state.

NOTE: Open wire detection limitations:

- If the external resistor value is greater than the maximum calculated resistance R_{EXT_MAX} , the open wire error might be reported even if the wire is not open.
- If the external resistor value is less than the minimum calculated resistance R_{EXT_MIN} , the corresponding digital input channel might see sensor state at 1 even if the sensor state is 0.
- If the supply monitoring function, page 176 is active and there is a loss of IO power supply, the open wire detection fault is not refreshed in Control Expert.

Supply Monitoring Function

The BMXDAl1615 module is a channel-to-channel isolated module, 16 channels get 16 common pins.

The module terminal block has only one supply monitor input (AC+) and its common pin is shared with the channel 15.

To extend the supply monitoring function to other channels, the common of the channel 15 needs to be connected to the common pins of the other channels. In consequence the channel-to-channel isolation will be given up.

By default the supply monitoring function is inactive. Refer to the chapter *Configuration*, page 342 for detailed information.

The IO supply state is monitored as follows:

- When the IO supply is higher than 170 Vac, the EXT_PS_FLT bit is at 0 which means IO power supply is ok.
- When the IO supply is lower than 80 Vac, the EXT_PS_FLT bit is at 1 which means a detected error on IO power supply. All channel input values are forced to 0.

BMX DAI 0805 Input Modules

What's in This Chapter

Introduction	177
Characteristics.....	178
Connecting the Module	180

Subject of this Section

This section presents the BMX DAI 0805 module, its characteristics, and explains how it is connected to the various sensors.

Introduction

Function

The BMX DAI 0805 module is a 200...240 VAC discrete module connected via a 20-pin terminal block. This module has 8 input channels that operate on alternating current.

Ruggedized Version

The BMX DAI 0805H (hardened) equipment is the ruggedized version of the BMX DAI 0805 (standard) equipment. It can be used at extended temperatures and in harsh chemical environments.

For more information, refer to chapter *Installation in More Severe Environments* (see Modicon M580, M340, and X80 I/O Platforms, Standards and Certifications).

Illustration

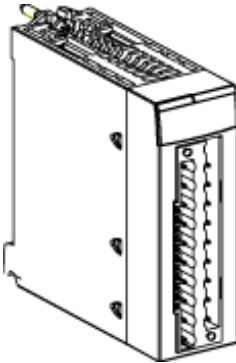

Characteristics

Altitude Operating Conditions

The characteristics in the table below apply to the modules BMX DAI 0805 and BMX DAI 0805H for use at altitude up to 2000 m (6560 ft). When the modules operate above 2000 m (6560 ft), apply additional derating.

For detailed information, refer to chapter *Operating and Storage Conditions* (see Modicon M580, M340, and X80 I/O Platforms, Standards and Certifications).

General Characteristics

This table presents the general characteristics for the BMX DAI 0805 and BMX DAI 0805H module:

Module type		200...240 VAC inputs
Operating temperature	BMX DAI 0805	0...60 °C (32...140 °F)
	BMX DAI 0805H	-25...70 °C (-13...158 °F)
Absolute maximum input	Continuous	264 VAC
	10s	300 VAC
	1 cycle	400 VAC
Nominal input values	Voltage	200...240 VAC
	Current	10.40 mA (for U=220 V at 50 Hz)
	Frequency	50/60Hz

Threshold input values	At 1	Voltage	≥ 159 V
		Current	> 6 mA (for U=159)
	At 0	Voltage	≤ 40 V
		Current	≤ 4 mA
	Frequency		47 Hz to 63 Hz
	Sensor supply (including ripple)		170...264 V
Peak of current on enabling (at nominal U)		480 mA	
Input impedance	at nominal U and $f = 55$ Hz		21 k Ω
Response time	Activation		10 ms
	Deactivation		20 ms
Input type			Capacitive
Input type in compliance with IEC 61131-2 standard			Type 2
2-wire / 3-wire proximity sensor compatibility (IEC 60947-5-2 standard compliant)			2-wire (AC), page 87
Reliability	MTBF for continuous operation in hours at ambient temperature 30 °C (86 °F)		1 730 522
Fuse type	Internal		None
	External		Fast blow fuse of 0.5 A
Dielectric strength			1500 V rms, 50 / 60 Hz for 1 min.
Resistance of insulation			>10 M Ω (below 500 VDC)
Sensor voltage: monitoring threshold	OK		> 164 V
	Error		< 80 V
Sensor voltage: monitoring response time	on appearance		$20 \text{ ms} < T < 50 \text{ ms}$
	on disappearance		$5 \text{ ms} < T < 15 \text{ ms}$
Power consumption 3.3 V	typical		76 mA
	maximum		126 mA
Sensor supply consumption	typical		93.60 mA
	maximum		154.80 mA
Power dissipation			4.73 W max.

Connecting the Module

At a Glance

The BMX DAI 0805 module is fitted with a removable 20-pin terminal block for the connection of eight input channels.

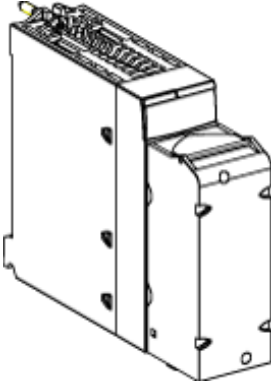

Input Circuit Diagram

The following diagram shows the circuit of an alternating current input.

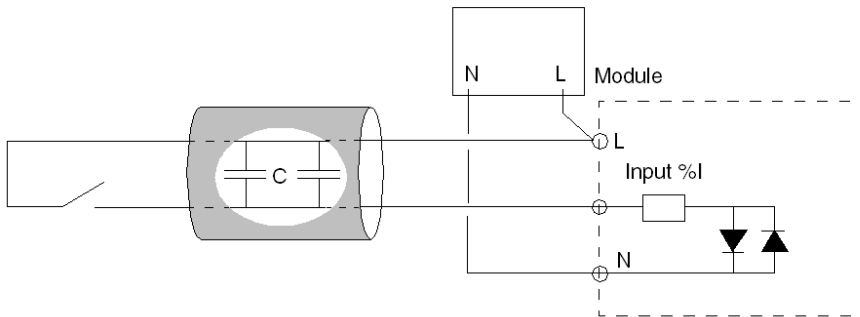

Module Connection

DANGER

HAZARD OF ELECTRICAL SHOCK, EXPLOSION OR ARC FLASH

Switch off the sensor and pre-actuator voltages before connecting or disconnecting the module.

Failure to follow these instructions will result in death or serious injury.

CAUTION

LOSS OF INPUT FUNCTION

Install the correct type of fuse with the correct rating.

Failure to follow these instructions can result in injury or equipment damage.

The following diagram shows the connection of the module to the sensors.

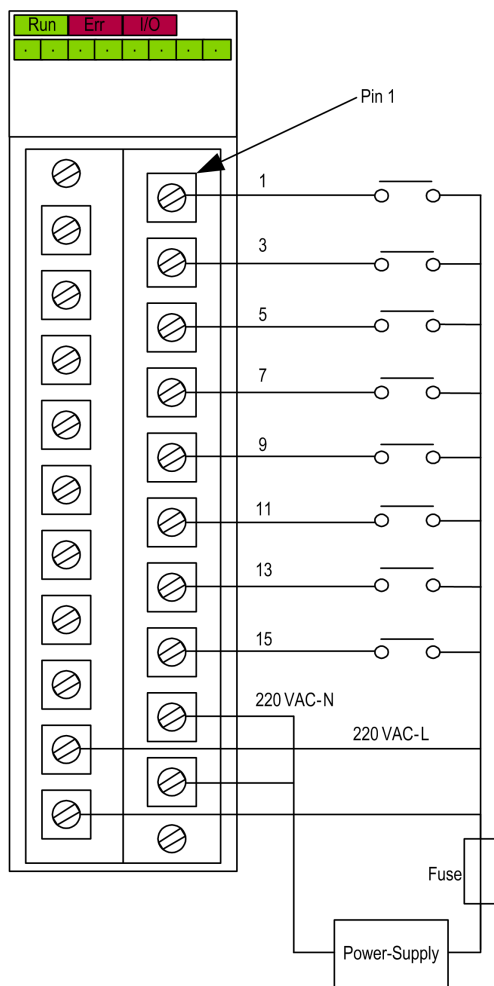

power supply: 200...240 VAC

fuse: fast blow fuse of 0.5A

BMX DAI 0814 Input Module

What's in This Chapter

Introduction	183
Characteristics.....	184
Connecting the Module	185

Subject of this Section

This section presents the BMX DAI 0814 module, its characteristics, and explains how it is connected to the various sensors.

Introduction

Function

The BMX DAI 0814 module is a 100...120 Vac discrete module connected via a 20-pin terminal block. The module has 8 isolated input channels that operate on alternating current.

Illustration

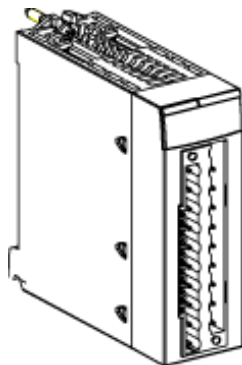

Characteristics

Altitude Operating Conditions

The characteristics in the table below apply to the module BMX DAI 0814 for use at altitude up to 2000 m (6560 ft). When the module operates above 2000 m (6560 ft), apply additional derating.

For detailed information, refer to chapter *Operating and Storage Conditions* (see Modicon M580, M340, and X80 I/O Platforms, Standards and Certifications).

General Characteristics

This table presents the general characteristics for the BMX DAI 0814 module:

Module type		100...120 Vac inputs	
Operating temperature		0...60 °C (32...140 °F)	
Nominal input values		Voltage	100...120 Vac
		Current	5 mA
		Frequency	50/60Hz
Threshold input values	At 1	Voltage	≥ 74 V
		Current	≥ 2.5 mA
	At 0	Voltage	≤ 20 V
		Current	≤ 1 mA
	Frequency		47 Hz to 63 Hz
	Sensor supply (including ripple)		85...132 V
	Peak of current on enabling (at nominal U)		240 mA
Input impedance	at nominal U and f = 55 Hz		13 kΩ
Response time	Activation		10 ms
	Deactivation		20 ms
Input type		Capacitive	
Input type in compliance with IEC 61131-2 standard		Type 3	
2-wire / 3-wire proximity sensor compatibility (IEC 60947-5-2 standard compliant)		2-wire (AC), page 87	

Reliability	MTBF for continuous operation in hours at ambient temperature 30 °C (86 °F)	1700000
Fuse type	Internal	None
	External	Fast blow fuse of 0.25 A
Power consumption 3.3 V	typical	61 mA
	maximum	112 mA
Dielectric strength	Channel to Bus	1780 V actual, 50 / 60 Hz for 1 min.
	Channel to Channel	1780 V actual, 50 / 60 Hz for 1 min.
Resistance of insulation	Channel to Bus	>10 MΩ (below 500 VDC)
	Channel to Channel	>10 MΩ (below 500 VDC)
Power dissipation		2.35 W max.

Connecting the Module

At a Glance

The BMX DAI 0814 module is fitted with a removable 20-pin terminal block for the connection of eight input channels.

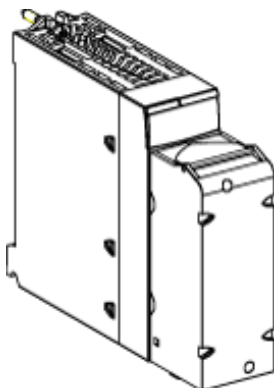

Input Circuit Diagram

The following diagram shows the circuit of an alternating current input.

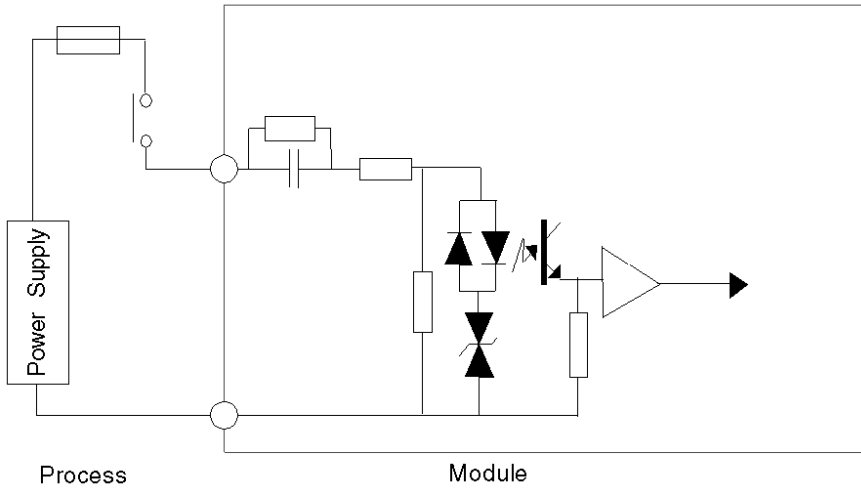

Module Connection

⚡ ⚠ DANGER

HAZARD OF ELECTRICAL SHOCK, EXPLOSION OR ARC FLASH

Switch off the sensor and pre-actuator voltages before connecting or disconnecting the module.

Failure to follow these instructions will result in death or serious injury.

⚠ CAUTION

LOSS OF INPUT FUNCTION

Install the correct type of fuse with the correct rating.

Failure to follow these instructions can result in injury or equipment damage.

The following diagram shows the connection of the sensors to the module.

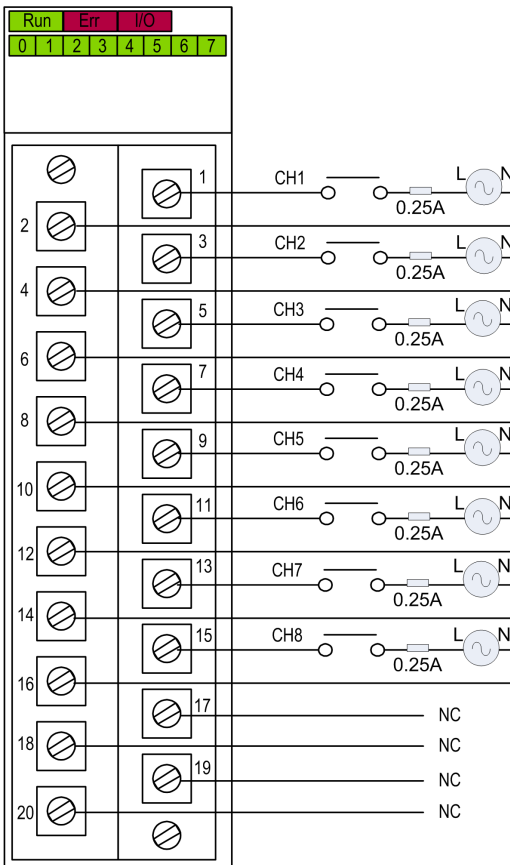

power supply: 100...120 VAC

fuse: fast blow fuse of 0.25A

NC not connected

BMX DDI 3202 K Input Modules

What's in This Chapter

Introduction	188
Characteristics.....	189
Connecting the Module	191

Subject of this Section

This section presents the BMX DDI 3202 K module, its characteristics and explains how it is connected to the various sensors.

Introduction

Function

The BMX DDI 3202 K module is a 24 VDC discrete module connected via a 40-pin connector. It is a positive logic (or sink) module: its 32 input channels receive current from the sensors.

Ruggedized Version

The BMX DDI 3202KH (hardened) equipment is the ruggedized version of the BMX DDI 3202K (standard) equipment. It can be used at extended temperatures and in harsh chemical environments.

For more information, refer to chapter *Installation in More Severe Environments* (see Modicon M580, M340, and X80 I/O Platforms, Standards and Certifications).

Illustration

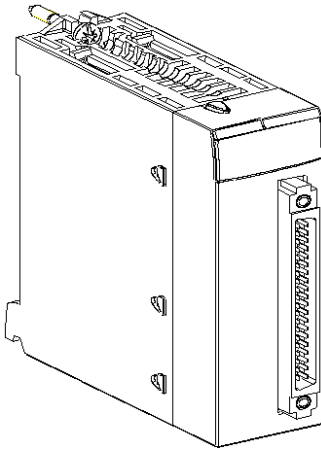

Characteristics

Altitude Operating Conditions

The characteristics in the table below apply to the modules BMX DDI 3202K and BMX DDI 3202KH for use at altitude up to 2000 m (6560 ft). When the modules operate above 2000 m (6560 ft), apply additional derating.

For detailed information, refer to chapter *Operating and Storage Conditions* (see Modicon M580, M340, and X80 I/O Platforms, Standards and Certifications).

General Characteristics

This table presents the general characteristics for the BMX DDI 3202 K and BMX DDI 3202 KH modules.

Module type		24 VDC positive logic inputs	
Operating temperature	BMX DDI 3202 K	0...60 °C (32...140 °F)	
	BMX DDI 3202 KH	-25...70 °C (-13...158 °F)	
Nominal input values		Voltage	24 VDC
		Current	2.5 mA
Threshold input values	At 1	Voltage	≥ 11 V
		Current	> 2 mA (for U ≥ 11 V)

	At 0	Voltage	5 V
		Current	< 0.5 mA
	Sensor supply (including ripple)		19...30 V (possible up to 34 V, limited to 1 hour/day)
Input impedance	at nominal U		9.6 kΩ
Response time	typical		4 ms
	maximum		7 ms
Input type			Current sink
Input type in compliance with IEC 61131-2 standard			Type 1
Reverse polarity			Protected
Fuse type	Internal		None
	External		1 fast blow fuse of 0.5 A for each 16-channel group
2-wire / 3-wire proximity sensor compatibility (IEC 60947-5-2 standard compliant)			2-wire (DC), and 3-wire (DC) PNP any type, page 87
Dielectric strength	Primary/Secondary		1500 V actual, 50 / 60 Hz for 1 min.
	Between channel groups		500 VDC
Resistance of insulation			>10 MΩ (below 500 VDC)
Paralleling of inputs			No
Reliability	MTBF in hours at ambient temperature 30 °C (86 °F)		696 320
Sensor voltage: monitoring threshold	OK		> 18 VDC
	Error		< 14 VDC
Sensor voltage: monitoring response time at 24 V (-15% ... +20%)	on appearance		1 ms < T < 3 ms
	on disappearance		8 ms < T < 30 ms
Power consumption 3.3 V	typical		121 mA
	maximum		160 mA
Sensor supply consumption	typical		92 mA
	maximum		145 mA
Power dissipation			3.9 W max.

NOTE: For the **BMX DDI 3202 KH**, the maximum value of the sensor power supply must not exceed 26.4 V and the minimum value must not be less than 21.1 V when operated within 60...70 °C (140...158 °F).

▲ WARNING

OVERHEATING MODULE

Do not operate the **BMX DDI 3202 KH** within 60...70 °C (140...158 °F) if the sensor power supply is greater than 26.4 V or less than 21.1 V.

Failure to follow these instructions can result in death, serious injury, or equipment damage.

Connecting the Module

At a Glance

The BMX DDI 3202 K module is fitted with a 40-pin connector for the connection of thirty-two input channels.

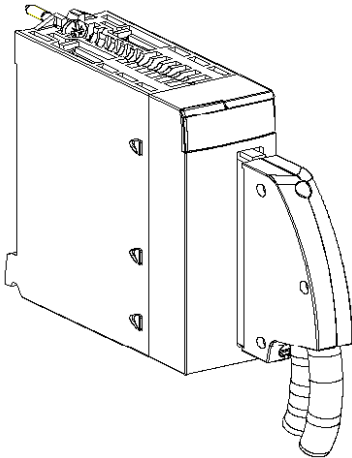

Input Circuit Diagram

The following diagram shows the circuit of a direct current input (positive logic).

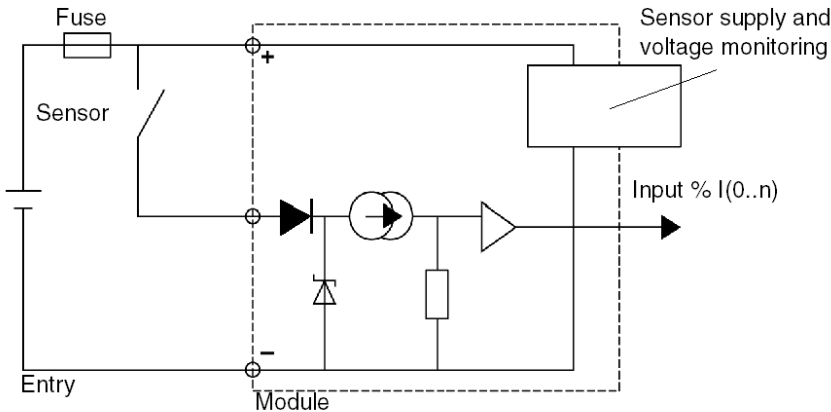

Module Connection

⚡ ⚠ DANGER
HAZARD OF ELECTRICAL SHOCK, EXPLOSION OR ARC FLASH
Switch off the sensor and pre-actuator voltages before connecting or disconnecting the module.
Failure to follow these instructions will result in death or serious injury.

⚠ CAUTION
LOSS OF INPUT FUNCTION
Install the correct rating and type of fuse.
Failure to follow these instructions can result in injury or equipment damage.

The following diagram shows the connection of the module to the sensors.

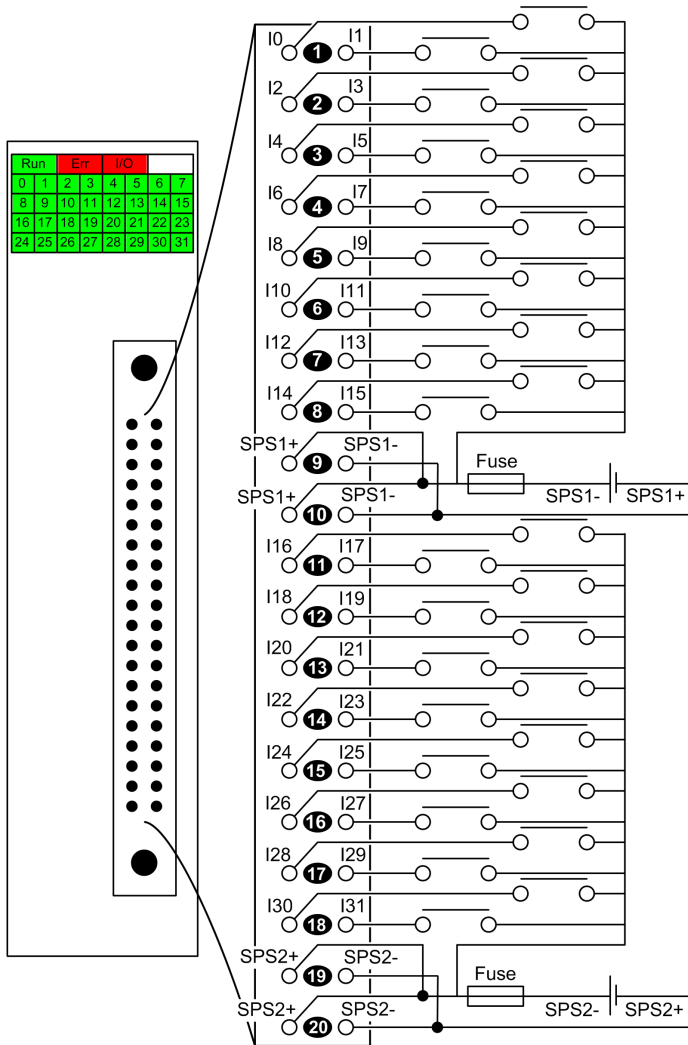

power supply: 24 VDC

fuse: fast blow fuse of 0.5 A for each 16-channel group

SPS: sensor power supply

Sensor Power Outage

After a power sensor outage, if the **Supply monitoring** check box is not selected in the module configuration screen then the digital input can stay active.

WARNING

DIGITAL INPUT STATE INACTIVE AFTER A SENSOR POWER OUTAGE

Do not click to clear the **Supply monitoring** check box in the module configuration screen to guarantee the digital input state inactive after sensor power outage.

Failure to follow these instructions can result in death, serious injury, or equipment damage.

To access the **Supply monitoring** check box, refer to chapter *How to Modify the External Power Supply Error Monitoring Parameter*, page 351.

After the sensor power outage, the I/O (red) LED of the module switches on and the last recorded position of the sensor is displayed by the input channel status LED's.

WARNING

CHANNEL LED INFORMATION NOT MATCHING SENSORS POSITION

After a sensor power outage:

- The I/O error LED is on
- Do not take into account the input LEDs information (they show the last recorded position of the sensors, not their real positions)
- Check the real positions on the sensors.

Failure to follow these instructions can result in death, serious injury, or equipment damage.

BMX DDI 6402 K Input Modules

What's in This Chapter

Introduction	195
Characteristics.....	196
Connecting the Module	198

Subject of this Section

This section presents the BMX DDI 6402 K module, its characteristics, and explains how it is connected to the various sensors.

Introduction

Function

The BMX DDI 6402 K module is a 24 VDC discrete module connected via two 40-pin connectors. It is a positive logic (or sink) module: its 64 input channels receive current from the sensors.

Ruggedized Version

The BMX DDI 6402KH (hardened) equipment is the ruggedized version of the BMX DDI 6402 (standard) equipment. It can be used at extended temperatures and in harsh chemical environments.

For more information, refer to chapter *Installation in More Severe Environments* (see Modicon M580, M340, and X80 I/O Platforms, Standards and Certifications).

Illustration

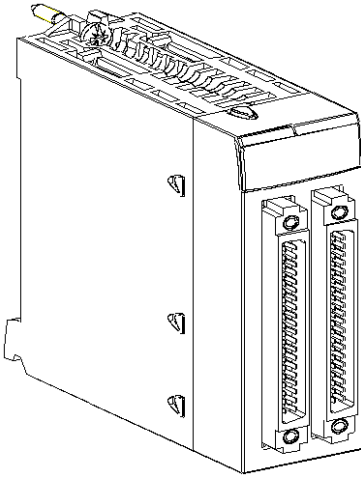

Characteristics

Altitude Operating Conditions

The characteristics in the table below apply to the modules BMX DDI 6402K and BMX DDI 6402KH for use at altitude up to 2000 m (6560 ft). When the modules operate above 2000 m (6560 ft), apply additional derating.

For detailed information, refer to chapter *Operating and Storage Conditions* (see Modicon M580, M340, and X80 I/O Platforms, Standards and Certifications).

General Characteristics

This table presents the general characteristics for the BMX DDI 6402 K and BMX DDI 6402 KH modules.

Module type		24 VDC positive logic inputs	
Operating temperature	BMX DDI 6402K	0...60 °C (32...140 °F)	
	BMX DDI 6402KH	-25...70 °C (-13...158 °F)	
Nominal input values		Voltage	24 VDC
		Current	0.6 mA
Threshold input values	At 1	Voltage	≥ 15 V

	At 0	Voltage	≤ 4 V
	Sensor supply (including ripple)		19...30 V (possible up to 34 V, limited to 1 hour/day)
Input impedance	at nominal U		40 kΩ
Response time	typical		4 ms
	maximum		7 ms
Reverse polarity			Protected
Fuse type	Internal		None
	External		1 fast blow fuse of 0.5 A for each 16-channel group
Type of input			Current sink
Input type in compliance with IEC 61131-2 standard			No type
2-wire / 3-wire proximity sensor compatibility (IEC 60947-5-2 standard compliant)			No compatibility (only 1 contact per sensor allowed)
Dielectric strength	Primary/Secondary		1500 V actual, 50 / 60 Hz for 1 min
	Between channel groups		500 VDC
Resistance of insulation			>10 MΩ (below 500 VDC)
Paralleling of inputs			No
Reliability	MTBF for continuous operation in hours at ambient temperature 30 °C (86 °F)		342 216
Sensor voltage: monitoring threshold	OK		> 18 V
	Error		< 14 V
Sensor voltage: monitoring response time at 24 V (-15% ... +20%)	on appearance		1 ms < T < 3 ms
	on disappearance		8 ms < T < 30 ms
Power consumption 3.3 V	typical		160 mA
	maximum		226 mA
Sensor supply consumption	typical		96 mA
	maximum		125 mA
Power dissipation			4.3 W max.

Connecting the Module

At a Glance

The BMX DDI 6402 K module is fitted with two 40-pin connectors for the connection of sixty-four input channels.

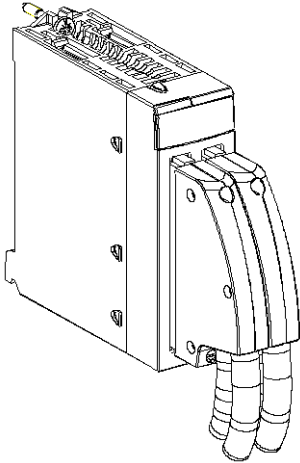

Input Circuit Diagram

The following diagram shows the circuit of a direct current input (positive logic).

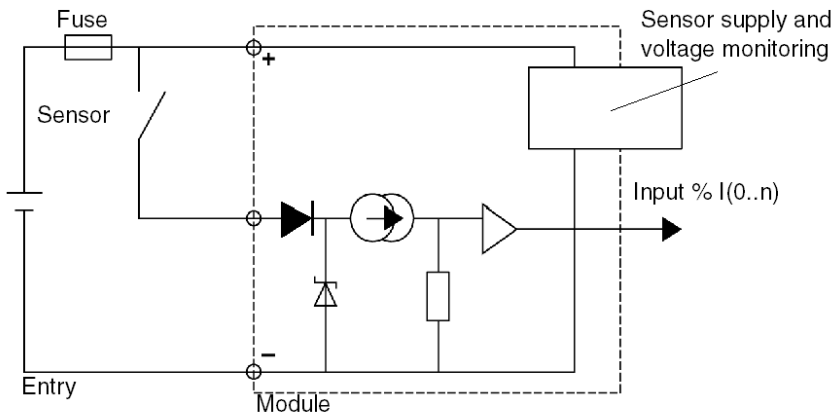

Module Connection

DANGER

HAZARD OF ELECTRICAL SHOCK, EXPLOSION OR ARC FLASH

Switch off the sensor and pre-actuator voltages before connecting or disconnecting the module.

Failure to follow these instructions will result in death or serious injury.

CAUTION

LOSS OF INPUT FUNCTION

Install the correct rating and type of fuse.

Failure to follow these instructions can result in injury or equipment damage.

The following diagram shows the connection of the module to the sensors.

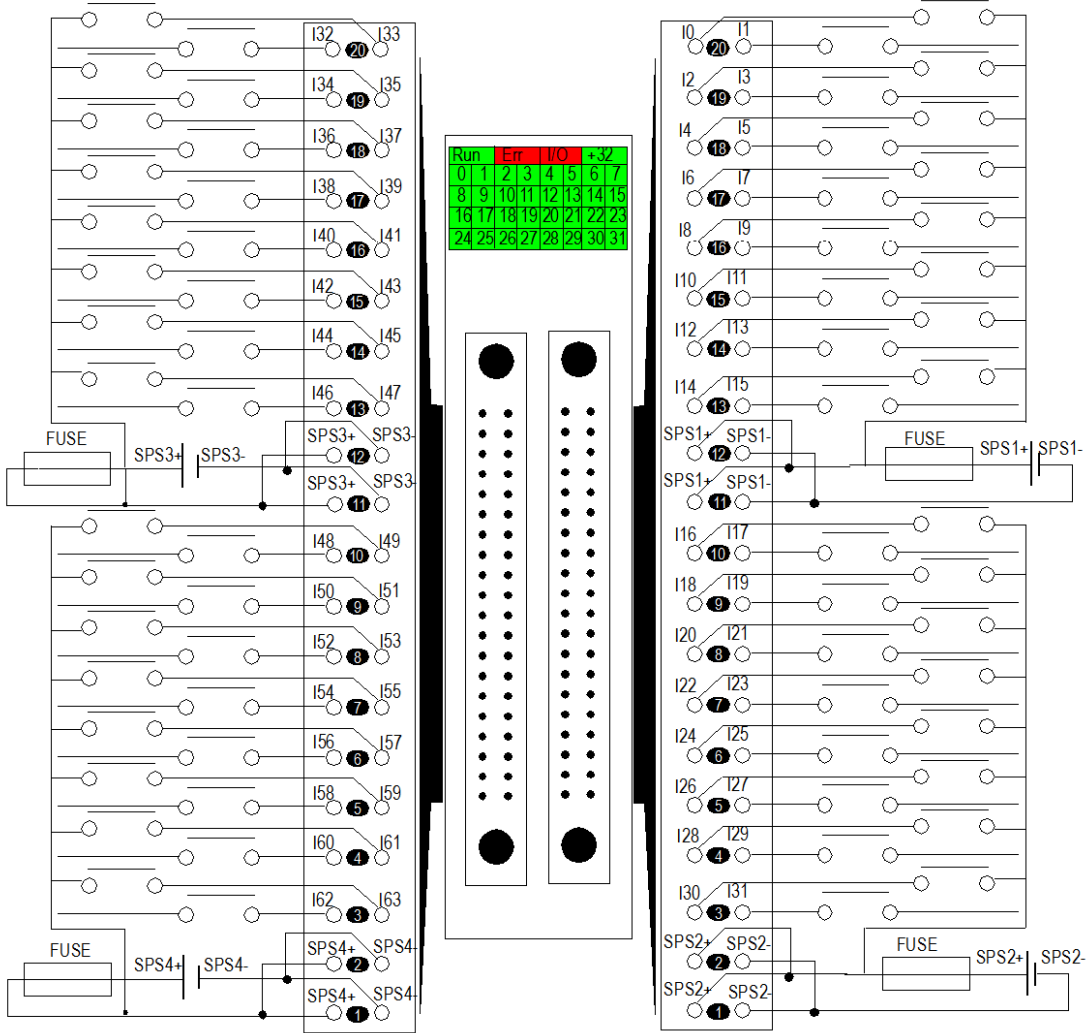

power supply: 24 VDC

fuse: fast blow fuse of 0.5 A for each 16-channel group

SPS: sensor power supply

Sensor Power Outage

After a power sensor outage, if the **Supply monitoring** check box is not selected in the module configuration screen then the digital input can stay active.

⚠ WARNING

DIGITAL INPUT STATE INACTIVE AFTER A SENSOR POWER OUTAGE

Do not click to clear the **Supply monitoring** check box in the module configuration screen to guarantee the digital input state inactive after sensor power outage.

Failure to follow these instructions can result in death, serious injury, or equipment damage.

To access the **Supply monitoring** check box, refer to chapter *How to Modify the External Power Supply Error Monitoring Parameter*, page 351.

After the sensor power outage, the I/O (red) LED of the module switches on and the last recorded position of the sensor is displayed by the input channel status LED's.

⚠ WARNING

CHANNEL LED INFORMATION NOT MATCHING SENSORS POSITION

After a sensor power outage:

- The I/O error LED is on
- Do not take into account the input LEDs information (they show the last recorded position of the sensors, not their real positions)
- Check the real positions on the sensors.

Failure to follow these instructions can result in death, serious injury, or equipment damage.

BMX DDO 1602 Static Output Modules

What's in This Chapter

Introduction	202
Characteristics.....	203
Connecting the Module	205

Subject of this Section

This section presents the BMX DDO 1602 module, its characteristics, and explains how it is connected to the pre-actuators.

Introduction

Function

The BMX DDO 1602 module is a 24 VDC discrete module connected via a 20-pin terminal block. It is a positive logic (or source) module: its 16 output channels provide current to the pre-actuators.

Ruggedized Version

The BMX DDO 1602H (hardened) equipment is the ruggedized version of the BMX DDO 1602 (standard) equipment. It can be used at extended temperatures and in harsh chemical environments.

For more information, refer to chapter *Installation in More Severe Environments* (see Modicon M580, M340, and X80 I/O Platforms, Standards and Certifications).

Illustration

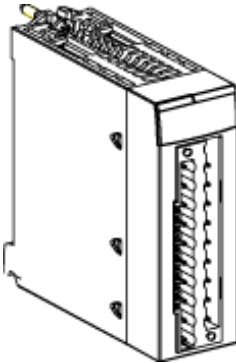

Characteristics

Altitude Operating Conditions

The characteristics in the table below apply to the modules BMX DDO 1602 and BMX DDO 1602H for use at altitude up to 2000 m (6560 ft). When the modules operate above 2000 m (6560 ft), apply additional derating.

For detailed information, refer to chapter *Operating and Storage Conditions* (see Modicon M580, M340, and X80 I/O Platforms, Standards and Certifications).

General Characteristics

This table presents the general characteristics for the BMX DDO 1602 and BMX DDO 1602H modules:

Module type		24 VDC positive logic static outputs
Operating temperature	BMX DDO 1602	0...60 °C (32...140 °F)
	BMX DDO 1602H	-25...70 °C (-13...158 °F)
Temperature derating		Apply the temperature derating curve , page 34
Nominal values	Voltage	24 VDC
	Current	0.5 A
Threshold values	Voltage (including ripple)	19...30 V (34 V possible for 1 hour/day)
	Current/channel	0.625 A

	Current/module	10 A
Power of tungsten filament lamp	Maximum	6 W
Leakage current	At 0	< 0.5 mA
Voltage drop	At 1	< 1.2 V
Load impedance	minimum	48 Ω
Response time⁽¹⁾		1.2 ms
Reliability	MTBF for continuous operation in hours at ambient temperature 30 °C (86°F)	392 285
Frequency of switching to inductive load		0.5 / LI ² Hz
Paralleling of outputs		Yes (maximum of 2)
Compatibility with IEC 61131-2 DC direct inputs		Yes (type 3 and no type)
Built-in protection	against over voltage	Yes, by Transil diode
	against inversions	Yes, by inverted diode ⁽²⁾
	against short-circuits and overloads	Yes, by current limiter and electric circuit-breaker 1.5 In < Id < 2 In
Fuse type	Internal	None
	External	1 fast blow fuse of 6.3 A
Pre-actuator voltage: monitoring threshold	OK	> 18 V
	Error	< 14 V
Pre-actuator voltage: monitoring response time	on appearance	8 ms < T < 30 ms
	on disappearance	1 ms < T < 3 ms
Power consumption 3.3 V	typical	79 mA
	maximum	111 mA
24 V pre-actuator consumption (excluding load current)	typical	23 mA
	maximum	32 mA
Power dissipation		4 W max.
Dielectric strength	Output / ground or output / internal logic	1500 V actual, 50 / 60 Hz for 1 min.
Resistance of insulation		>10 M Ω (below 500 VDC)
(1) All outputs are equipped with fast demagnetization circuits for electromagnets. Electromagnet discharge time < L/R.		
(2) Provide a fuse to the +24 V pre-actuator supply.		

NOTE: For the **BMX DDO 1602H**, the maximum pre-actuator power supply must not exceed 26.4 V and the output current value must not exceed 0.55 A at 70 °C (158 °F).

Connecting the Module

At a Glance

The BMX DDO 1602 module is fitted with a removable 20-pin terminal block for the connection of sixteen output channels.

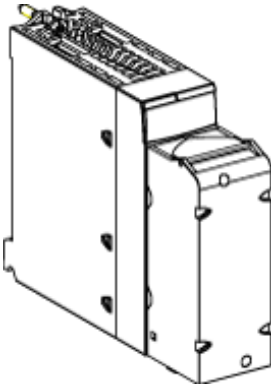

Output Circuit Diagram

The following diagram shows the circuit of a direct current output (positive logic).

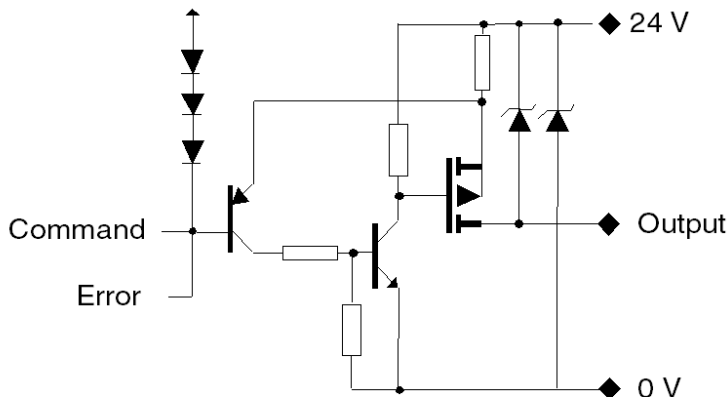

Module Connection

DANGER

HAZARD OF ELECTRICAL SHOCK, EXPLOSION OR ARC FLASH

Switch off the sensor and pre-actuator voltage before connecting or disconnecting the module.

Failure to follow these instructions will result in death or serious injury.

CAUTION

LOSS OF OUTPUT FUNCTION

Install the correct rating and type of fuse.

Failure to follow these instructions can result in injury or equipment damage.

The following diagram shows the connection of the module to the pre-actuators.

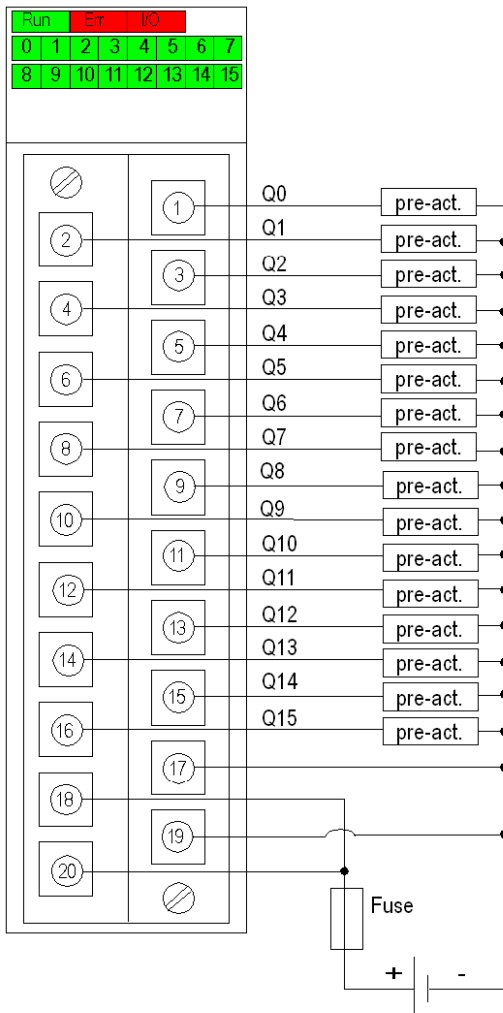

power supply: 24 VDC

fuse: fast blow fuse of 6.3 A

pre-act: pre-actuator

BMX DDO 1612 Static Output Modules

What's in This Chapter

Introduction	208
Characteristics.....	209
Connecting the Module	211

Subject of this Section

This section presents the BMX DDO 1612 module, its characteristics, and explains how it is connected to the pre-actuators.

Introduction

Function

The BMX DDO 1612 module is a 24 VDC discrete module connected via a 20-pin terminal block. It is a negative logic (or sink) module: its 16 output channels receive current from the pre-actuators.

Ruggedized Version

The BMX DDO 1612H (hardened) equipment is the ruggedized version of the BMX DDO 1612 (standard) equipment. It can be used at extended temperatures and in harsh chemical environments.

For more information, refer to chapter *Installation in More Severe Environments* (see Modicon M580, M340, and X80 I/O Platforms, Standards and Certifications).

Illustration

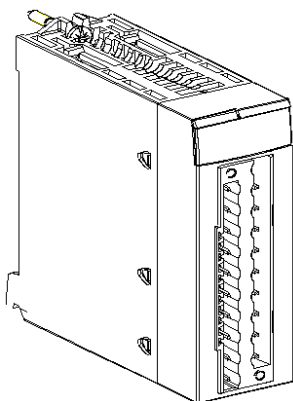

Characteristics

Altitude Operating Conditions

The characteristics in the table below apply to the modules BMX DDO 1612 and BMX DDO 1612H for use at altitude up to 2000 m (6560 ft). When the modules operate above 2000 m (6560 ft), apply additional derating.

For detailed information, refer to chapter *Operating and Storage Conditions* (see Modicon M580, M340, and X80 I/O Platforms, Standards and Certifications).

General Characteristics

This table presents the general characteristics for the BMX DDO 1612 and BMX DDO 1612H modules:

Module type		24 VDC negative logic static outputs
Operating temperature	BMX DDO 1612	0...60 °C (32...140 °F)
	BMX DDO 1612H	-25...70 °C (-13...158 °F)
Temperature derating		Apply the temperature derating curve , page 34
Nominal values	Voltage	24 VDC
	Current	0.5 A
Threshold values	Voltage (including ripple)	19...30 V (34 V possible for 1 hour/day)

	Current/channel	0.625 A
	Current/module	10 A
Power of tungsten filament lamp	Maximum	6 W
Leakage current	At 0	< 0.5 mA
Residual voltage	At 1	< 1.2 V
Load impedance	minimum	48 Ω
Response time⁽¹⁾		1.2 ms
Reliability	MTBF for continuous operation in hours at ambient temperature 30 °C (86 °F)	403 804
Frequency of switching to inductive load		0.5 / L ² Hz
Paralleling of outputs		Yes (maximum of 3)
Compatibility with DC inputs		Yes (source and no type inputs)
Built-in protection⁽²⁾	against over voltage	Yes, by Transil diode
	against reverse polarity	Yes, by reverse-mounted diode
	against short-circuits and overloads	Yes, by current limiter and electric circuit-breaker $1.5 I_n < I_d < 2 I_n$
Fuse type	Internal	None
	External	1 fast blow fuse of 6.3 A
Pre-actuator voltage: monitoring threshold	OK	> 18 V
	Error	< 14 V
Pre-actuator voltage: monitoring response time	on appearance	8 ms < T < 30 ms
	on disappearance	1 ms < T < 3 ms
Power consumption 3.3 V	typical	79 mA
	maximum	111 mA
24 V pre-actuator consumption (Excluding load current)	typical	23 mA
	maximum	32 mA
Power dissipation		2.26 W max.
Dielectric strength	Output / ground or output / internal logic	1500 V rms, 50 / 60 Hz for 1 min.
Resistance of insulation		>10 MΩ (below 500 VDC)
(1) All outputs are equipped with fast demagnetization circuits for electromagnets. Electromagnet discharge time < L/R.		
(2) Provide a fuse to the +24 V pre-actuator supply.		

NOTE: For the **BMX DDO 1612H**, the maximum pre-actuator power supply must not exceed 26.4 V and the output current value must not exceed 0.55 A at 70 °C (158 °F).

Connecting the Module

At a Glance

The BMX DDO 1612 module is fitted with a removable 20-pin terminal block for the connection of sixteen output channels.

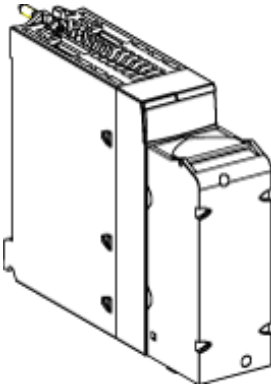

Output Circuit Diagram

The following diagram shows the circuit of a direct current output (negative logic).

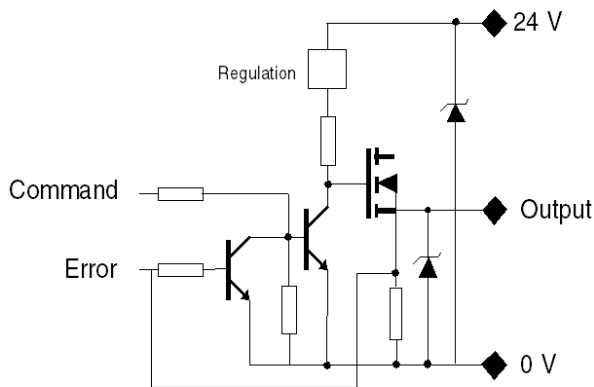

Module Connection

DANGER

HAZARD OF ELECTRICAL SHOCK, EXPLOSION OR ARC FLASH

Switch off the sensor and pre-actuator voltage before connecting or disconnecting the module.

Failure to follow these instructions will result in death or serious injury.

CAUTION

LOSS OF OUTPUT FUNCTION

Install the correct rating and type of fuse.

Failure to follow these instructions can result in injury or equipment damage.

The following diagram shows the connection of the module to the pre-actuators.

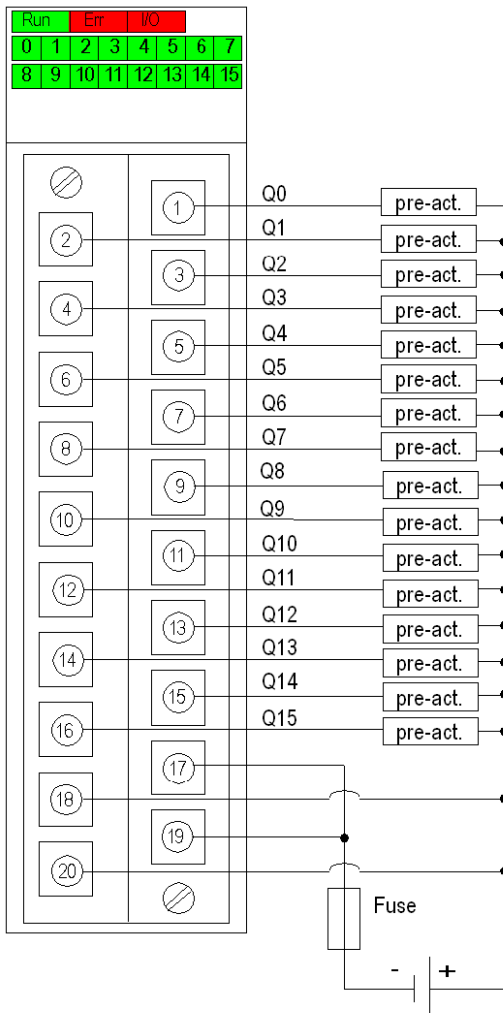

power supply: 24 VDC

fuse: fast blow fuse of 6.3 A

pre-act: pre-actuator

BMX DRA 0804T Relay Output Modules

What's in This Chapter

Introduction	214
Characteristics.....	215
Connecting the Module	216

Subject of this Section

This section presents the BMX DRA 0804T module, its characteristics, and explains how it is connected to the pre-actuators.

NOTE: There is no H version of this module.

Introduction

Function

The BMX DRA 0804T module is a 125 VDC discrete relay module connected via a 20-pin terminal block. Its 8 relay output channels operate on direct current.

NOTE: BMX DRA 0804T provides an extended temperature range, as listed in the General Characteristics, page 215 topic of this chapter.

Illustration

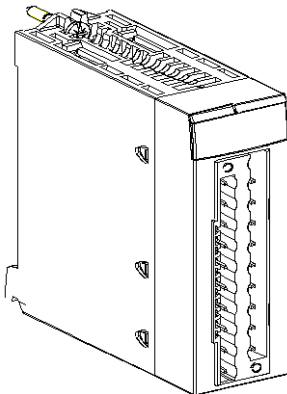

Characteristics

Altitude Operating Conditions

The characteristics in the table below apply to the module BMX DRA 0804T for use at altitude up to 2000 m (6560 ft). When the module operates above 2000 m (6560 ft), apply additional derating.

For detailed information, refer to chapter *Operating and Storage Conditions* (see Modicon M580, M340, and X80 I/O Platforms, Standards and Certifications).

General Characteristics

This table presents the general characteristics for the BMX DRA 0804T module:

Module type		Relay outputs for direct current	
Operating temperature		-25...70 °C (-13...158 °F)	
Rated voltage	Direct	125 VDC	
Voltage range	Direct	100...150 VDC	
Maximum switching current		0.3 A	
Response time	Activation	< 10 ms	
	Deactivation	< 10 ms	
Surge current maximum	10 A capacitive	t = 10 ms	
Built-in protection	Against inductive over voltage in DC modes	None. Fit a discharge diode on each output.	
	against short-circuits and overloads	None. Fit a fast-blow fuse of 0.5 A, 250 VDC for each relay.	
Reliability	MTBF for continuous operation in hours at ambient temperature 30 ° C (86 °F)	2 683 411	
Power dissipation		3.17 W maximum	
Field to Bus (Dielectric strength) (at 50/60 Hz for 1 min.)		2000 V actual	
Resistance of insulation (at 500 VDC)		>10 MΩ	
Power supply consumption	3.3 V	Typical	40 mA

	24 V (All channels stay at 1)	Maximum	75 mA
		Typical	101 mA
		Maximum	137 mA
Point to point isolation			1780 VAC rms
Output current			0.3 A at 125 VDC (resistive load) 100,000 ops. minimum
			0.1 A (L/R = 10 ms) 100,000 ops. minimum
Mechanical operations			20,000,000 minimum

Connecting the Module

At a Glance

The BMX DRA 0804T module is fitted with a removable 20-pin terminal block for the connection of eight relay output channels.

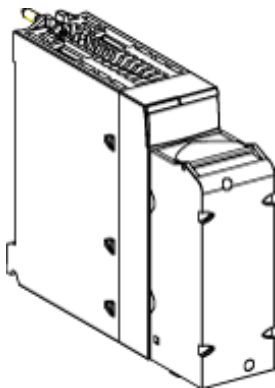

Output Circuit Diagram

The following diagram shows the circuit of a relay output. Note the enlargement of the pre-actuator. It is recommended to install this type of protection on the terminals of each pre-actuator.

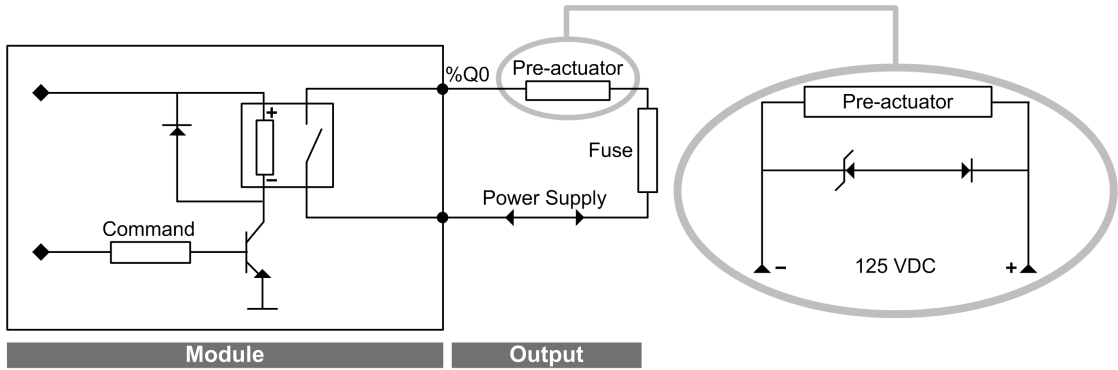

Module Connection

⚡⚠ DANGER

HAZARD OF ELECTRICAL SHOCK, EXPLOSION OR ARC FLASH

Switch off the sensor and pre-actuator voltages before connecting or disconnecting the module.

Failure to follow these instructions will result in death or serious injury.

⚠ CAUTION

LOSS OF OUTPUT FUNCTION

Install the correct rating and type of fuse.

Failure to follow these instructions can result in injury or equipment damage.

The following diagram shows the connection of the module to the pre-actuators.

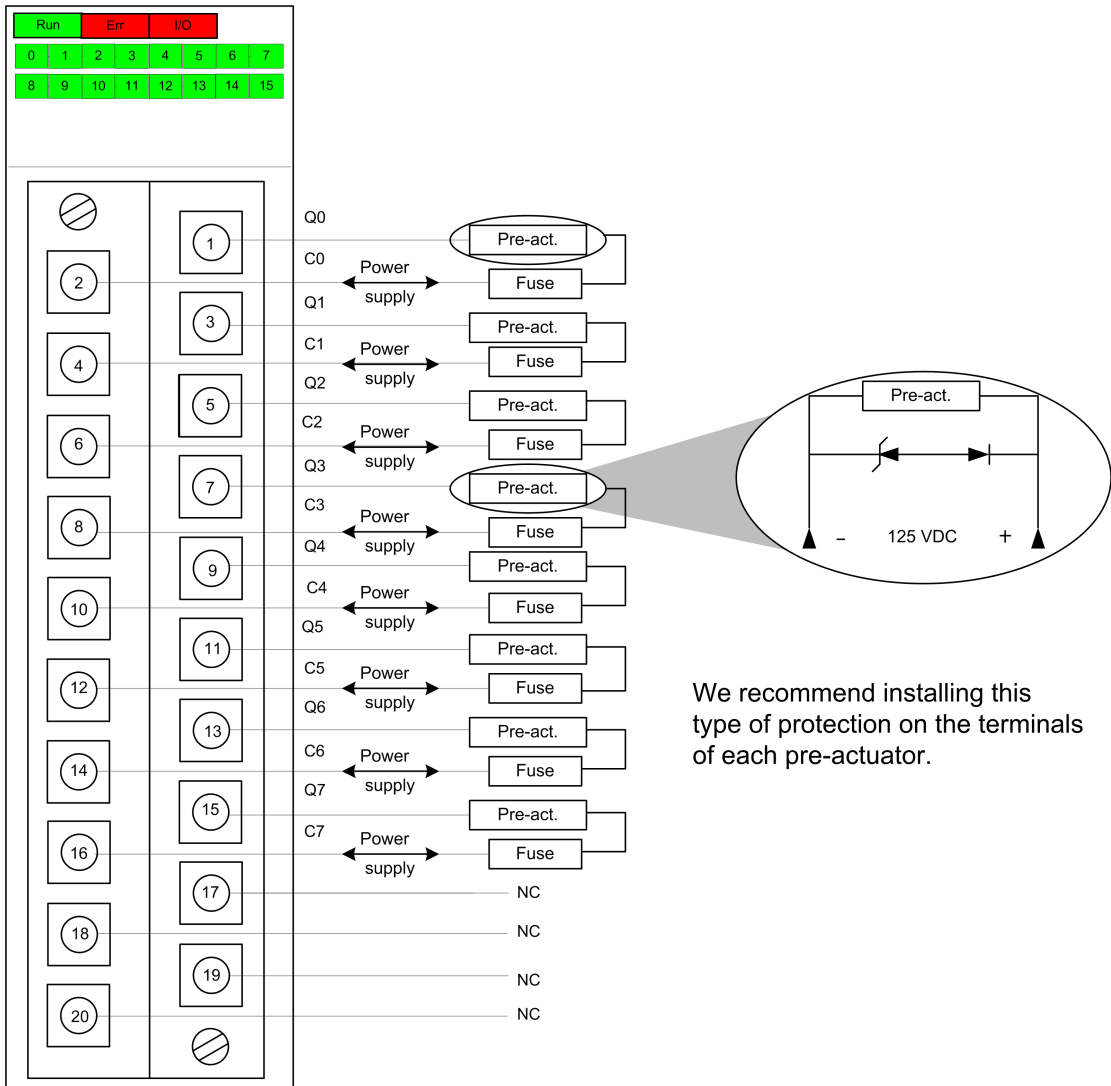

power supply: 125 VDC (100...150 VDC)

fuse: 1 fast blow fuse of 0.5 A, 250 VDC for each relay

NC: not connected

NOTE: A Zener Diode voltage of 47V or slightly higher is recommended.

BMX DRA 0805 Relay Output Modules

What's in This Chapter

Introduction	219
Characteristics.....	220
Connecting the Module	222

Subject of this Section

This section presents the BMX DRA 0805 module, its characteristics, and explains how it is connected to the pre-actuators.

Introduction

Function

The BMX DRA 0805 module is a 24 VDC or 24...240 VAC discrete module connected via a 20-pin terminal block. Its 8 relay output channels operate either on alternating current or direct current.

Ruggedized Version

The BMX DRA 0805H (hardened) equipment is the ruggedized version of the BMX DRA 0805 (standard) equipment. It can be used at extended temperatures and in harsh chemical environments.

For more information, refer to chapter *Installation in More Severe Environments* (see Modicon M580, M340, and X80 I/O Platforms, Standards and Certifications).

Illustration

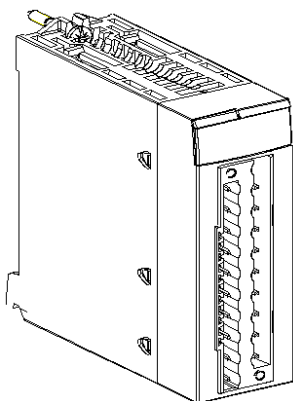

Characteristics

Altitude Operating Conditions

The characteristics in the table below apply to the modules BMX DRA 0805 and BMX DRA 0805H for use at altitude up to 2000 m (6560 ft). When the modules operate above 2000 m (6560 ft), apply additional derating.

For detailed information, refer to chapter *Operating and Storage Conditions* (see Modicon M580, M340, and X80 I/O Platforms, Standards and Certifications).

General Characteristics

This table presents the general characteristics for the BMX DRA 0805 and BMX DRA 0805H modules:

Module type		Relay outputs for alternating and direct current
Operating temperature	BMX DRA 0805	0...60 °C (32...140 °F)
	BMX DRA 0805H	-25...70 °C (-13...158 °F)
Rated voltage	Direct	24 VDC
	Alternating	24...240 VAC
Voltage range	Direct	10...34 VDC
	Alternating	19...264 VAC (47...63 Hz)
Thermal current		3 A

Minimum switching load		5 VDC / 10 mA			
Alternating current load in resistive mode (AC12)	Voltage	24 VAC	48 VAC	100...120 VAC	200...240 VAC
	Power	50 VA ⁽⁵⁾	50 VA ⁽⁶⁾ 110 VA ⁽⁴⁾	110 VA ⁽⁶⁾ 220 VA ⁽⁴⁾	220 VA ⁽⁶⁾
	Maximum Power of Hardened module at 70°C (158°F)	30 VA ⁽⁵⁾	30 VA ⁽⁶⁾ 66 VA ⁽⁴⁾	66 VA ⁽⁶⁾ 132 VA ⁽⁴⁾	132 VA ⁽⁶⁾
Alternating current load in inductive mode (AC15)	Voltage	24 VAC	48 VAC	100...120 VAC	200...240 VAC
	Power	24 VA ⁽⁴⁾	10 VA ⁽¹⁰⁾ 24 VA ⁽⁸⁾	10 VA ⁽¹¹⁾ 50 VA ⁽⁷⁾ 110 VA ⁽²⁾	10 VA ⁽¹¹⁾ 50 VA ⁽⁹⁾ 110 VA ⁽⁶⁾ 220 VA ⁽¹⁾
	Maximum Power of Hardened module at 70°C (158°F)	14.4 VA ⁽⁴⁾	6 VA ⁽¹⁰⁾ 14.4 VA ⁽⁸⁾	6 VA ⁽¹¹⁾ 30 VA ⁽⁷⁾ 66 VA ⁽²⁾	6 VA ⁽¹¹⁾ 30 VA ⁽⁹⁾ 66 VA ⁽⁶⁾ 132 VA ⁽¹⁾
Direct current load in resistive mode (DC12)	Voltage	24 VDC			
	Power	24 W ⁽⁶⁾ 40 W ⁽³⁾			
	Maximum Power of Hardened module at 70°C (158°F)	14.4 W ⁽⁶⁾ 24 W ⁽³⁾			
Direct current load in inductive mode (DC13) (L:R=60 ms)	Voltage	24 VDC			
	Power	10 W ⁽⁸⁾ 24 W ⁽⁶⁾			
	Maximum Power of Hardened module at 70°C (158°F)	6 W ⁽⁸⁾ 14.4 W ⁽⁶⁾			
Response time	Activation	< 10 ms			
	Deactivation	< 8 ms			
Built-in protection	Against inductive over voltage in AC modes	None. Fit an RC circuit or a ZNO type over voltage limiter in parallel on each output appropriate to the voltage in use.			
	Against inductive over voltage in DC modes	None. Fit a discharge diode on each output.			

	against short-circuits and overloads	None. Fit a fast-blow fuse of 3 A for each relay.	
Reliability	MTBF for continuous operation in hours at ambient temperature 30°C (86°F)	2 119 902	
Power dissipation		2.7 W max.	
Dielectric strength (at 50/60 Hz for 1 min.)		2000 V actual	
Resistance of insulation (at 500 VDC)		>10 MΩ	
Power supply consumption	3.3 V	Typical	79 mA
		Maximum	111 mA
	24 V relay (12)	Typical	51 mA
		Maximum	56 mA
(1): 0.1 x 10 ⁶ cycles, (2): 0.15 x 10 ⁶ cycles, (3): 0.3 x 10 ⁶ cycles, (4): 0.5 x 10 ⁶ cycles, (5): 0.7 x 10 ⁶ cycles, (6): 1 x 10 ⁶ cycles, (7): 1.5 x 10 ⁶ cycles, (8): 2 x 10 ⁶ cycles, (9): 3 x 10 ⁶ cycles, (10): 5 x 10 ⁶ cycles, (11): 10 x 10 ⁶ cycles, (12): all channels at 1.			

Connecting the Module

At a Glance

The BMX DRA 0805 module is fitted with a removable 20-pin terminal block for the connection of eight relay output channels.

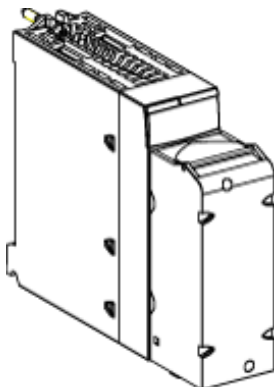

Output Circuit Diagram

The following diagram shows the circuit of a relay output.

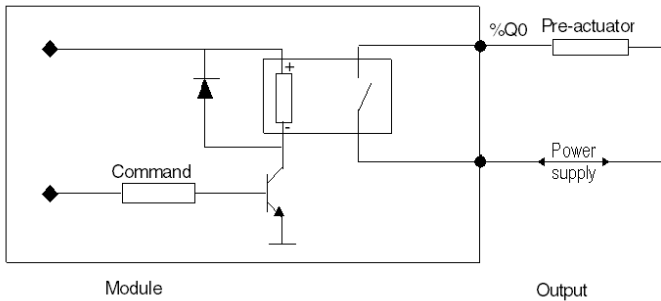

Module Connection

⚡ ⚠ DANGER

HAZARD OF ELECTRICAL SHOCK, EXPLOSION OR ARC FLASH

Switch off the sensor and pre-actuator voltages before connecting or disconnecting the module.

Failure to follow these instructions will result in death or serious injury.

⚠ CAUTION

LOSS OF OUTPUT FUNCTION

Install the correct rating and type of fuse.

Failure to follow these instructions can result in injury or equipment damage.

The following diagram shows the connection of the module to the pre-actuators.

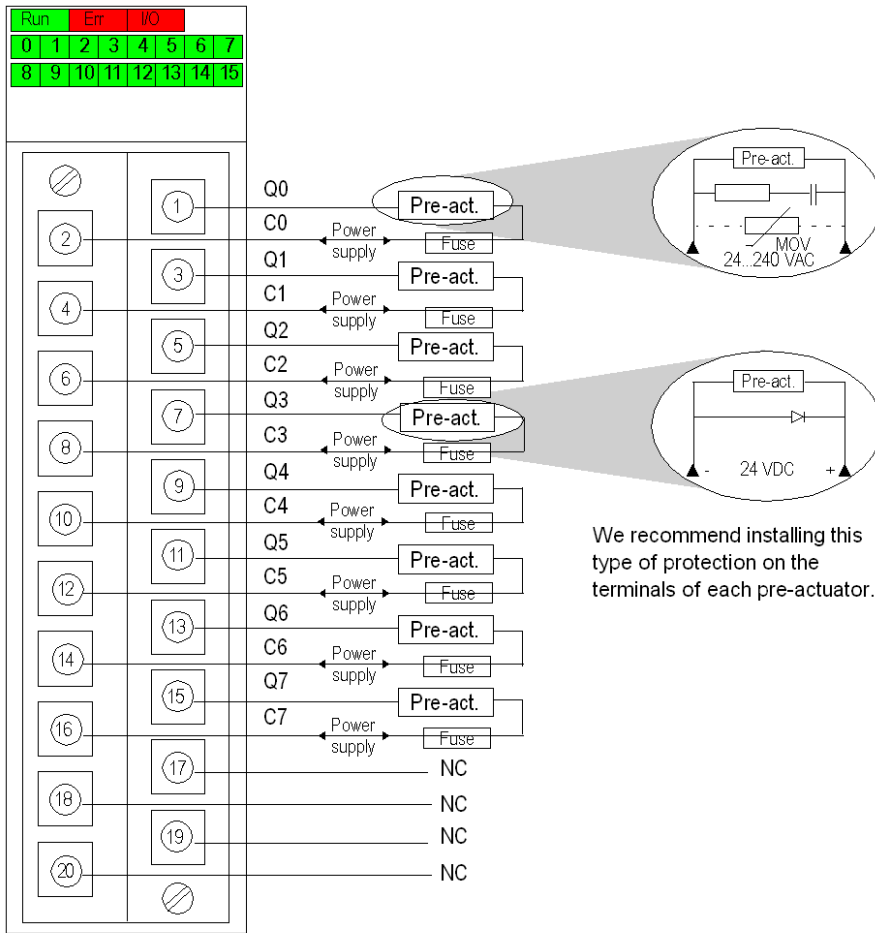

power supply: 24 VDC or 24...240 VAC

fuse: 1 fast blow fuse of 3 A for each relay

NC: not connected

We recommend installing this type of protection on the terminals of each pre-actuator.

BMX DRA 0815 Relay Output Modules

What's in This Chapter

Introduction	225
Characteristics.....	226
Connecting the Module	229

Subject of this Section

This section presents the BMX DRA 0815 module, its characteristics, and explains how it is connected to the pre-actuators.

Introduction

Function

The BMX DRA 0815 module is a 5...125 VDC or 24...240 VAC discrete module connected via a 20-pin terminal block. Its 8 relay output channels operate either on alternating current or direct current.

Ruggedized Version

The BMX DRA 0815H (hardened) equipment is the ruggedized version of the BMX DRA 0815 (standard) equipment. It can be used at extended temperatures and in harsh chemical environments.

For more information, refer to chapter *Installation in More Severe Environments* (see Modicon M580, M340, and X80 I/O Platforms, Standards and Certifications).

Illustration

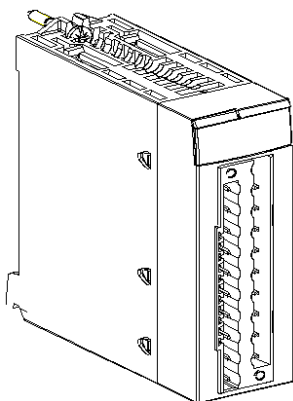

Characteristics

Altitude Operating Conditions

The characteristics in the table below apply to the modules BMX DRA 0815 and BMX DRA 0815H for use at altitude up to 2000 m (6560 ft). When the modules operate above 2000 m (6560 ft), apply additional derating.

For detailed information, refer to chapter *Operating and Storage Conditions* (see Modicon M580, M340, and X80 I/O Platforms, Standards and Certifications).

General Characteristics

This table presents the general characteristics for the BMX DRA 0815 and BMX DRA 0815H modules:

Module type		Relay outputs for alternating and direct current
Rated range	Alternating	24...240 Vac
	Direct	24...125 Vdc
Voltage range	Alternating	19...264 Vac (47...63 Hz)
	Direct	5...150 Vdc
Operating temperature	BMX DRA 0815	0 °C to 60 °C (32 °F to 140 °F) with derating (see hereafter).
	BMX DRA 0815H	-25 °C to 70 °C (-13 °F to 158 °F) with derating (see hereafter).

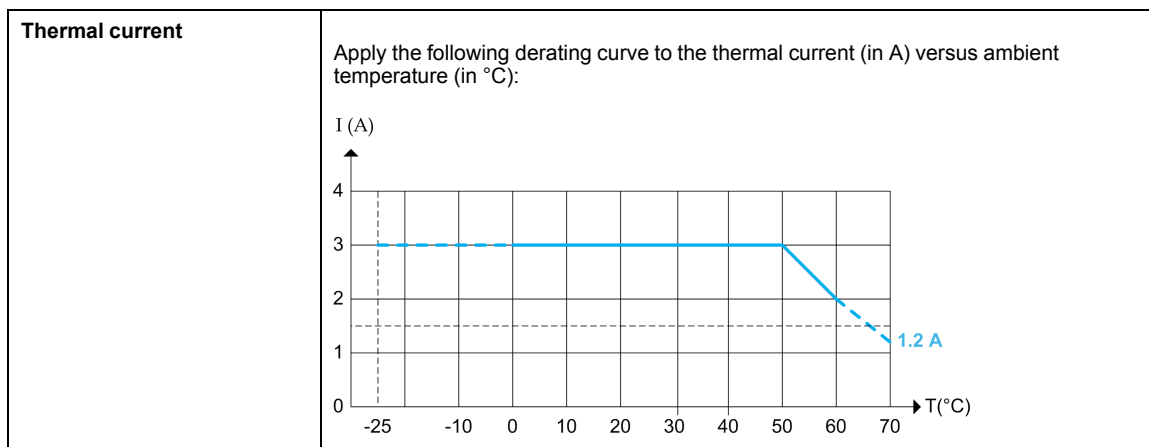

Minimum switching load		5 Vdc / 10 mA			
Alternating current load in resistive mode (AC12)	Voltage	24 Vac	48 Vac	100...120 Vac	200...250 Vac
	Switching power below 60 °C (140 °F)	48 VA ⁽⁷⁾	48 VA ⁽⁸⁾ 96 VA ⁽⁶⁾	110 VA ⁽⁸⁾ 220 VA ⁽⁶⁾	220 VA ⁽⁸⁾ 500 VA ⁽⁶⁾
	Maximum switching power of hardened module at 60...70 °C (140...158 °F)	28.8 VA ⁽⁷⁾	28.8 VA ⁽⁸⁾ 57.6 VA ⁽⁶⁾	66 VA ⁽⁸⁾ 132 VA ⁽⁶⁾	132 VA ⁽⁸⁾ 300 VA ⁽⁶⁾
Alternating current load in inductive mode (AC15) (Power factor = 0.4)	Voltage	24 Vac	48 Vac	100...120 Vac	200...250 Vac
	Switching power below 60 °C (140 °F)	10 VA ⁽¹⁰⁾ 24 VA ⁽⁹⁾ 48 VA ⁽⁶⁾ 72 VA ⁽⁴⁾⁽¹³⁾	10 VA ⁽¹⁰⁾ 24 VA ⁽⁹⁾ 48 VA ⁽⁸⁾ 96 VA ⁽⁵⁾ 144 VA ⁽³⁾⁽¹³⁾	10 VA ⁽¹¹⁾ 50 VA ⁽⁸⁾ 110 VA ⁽⁷⁾ 220 VA ⁽⁴⁾ 360 VA ⁽²⁾⁽¹³⁾	10 VA ⁽¹¹⁾ 50 VA ⁽⁹⁾ 110 VA ⁽⁷⁾ 220 VA ⁽⁶⁾ 500 VA ⁽³⁾ 750 VA ⁽¹⁾⁽¹³⁾
	Maximum switching power of hardened module at 60...70 °C (140...158 °F)	6 VA ⁽¹⁰⁾ 14.4 VA ⁽⁹⁾ 28.8 VA ⁽⁶⁾	6 VA ⁽¹⁰⁾ 14.4 VA ⁽⁹⁾ 28.8 VA ⁽⁸⁾ 57.6 VA ⁽⁵⁾	6 VA ⁽¹¹⁾ 30 VA ⁽⁸⁾ 66 VA ⁽⁷⁾ 132 VA ⁽⁴⁾	6 VA ⁽¹¹⁾ 30 VA ⁽⁹⁾ 66 VA ⁽⁷⁾ 132 VA ⁽⁶⁾ 300 VA ⁽³⁾
Direct current load in resistive mode (DC12)	Voltage	24 Vdc	48...60 Vdc	100...125 Vdc	

(L:R = 1 ms)	Switching power below 60 °C (140 °F)	24 W ⁽⁷⁾ 48 W ⁽⁶⁾	40 W ⁽⁶⁾	45 W ⁽⁵⁾
	Maximum switching power of hardened module at 60...70 °C (140...158 °F)	14.4 W ⁽⁷⁾ 28.8 W ⁽⁶⁾	24 W ⁽⁶⁾	45 W ⁽³⁾
Direct current load in inductive mode (DC13) (L:R = 15 ms)	Voltage	24 Vdc	48...60 Vdc	110...125 Vdc
	Switching power below 60 °C (140 °F)	10 W ⁽⁵⁾ 24 W ⁽³⁾ 48 W ⁽¹⁾	40 W ⁽¹⁾	15 W ⁽⁵⁾
	Maximum switching power of hardened module at 60...70 °C (140...158 °F)	6 W ⁽⁵⁾ 14.4 W ⁽³⁾ 28.8 W ⁽¹⁾	24 W ⁽¹⁾	15 W ⁽¹⁾
Mechanical operations		20,000,000 minimum		
Response time	Activation	< 10 ms		
	Deactivation	< 13 ms		
Surge current maximum	10 A capacitive	t = 10 ms		
Built-in protection	Against inductive over voltage in AC modes	None. Fit an RC circuit or a ZNO type over voltage limiter in parallel on each output channel appropriate to the voltage in use.		
	Against inductive over voltage in DC modes	None. Fit a discharge diode on each output channel.		
	Against short-circuits and overloads	None. Fit a fast-blow fuse on each output channel or channel group. NOTE: The current capability of fuse depends on the maximum switching load.		
Reliability	MTBF for continuous operation in hours at ambient temperature 30 °C (86 °F)	2,683,411		
Power dissipation⁽¹²⁾		3.6 W + 0.03 x (I1 ² + I2 ² + ... + I8 ²) Where I1, I2,...I8 is the load current for each channel.		
Dielectric strength (at 50/60 Hz for 1 min.)	Channel to X-bus	3000 Vac		
	Channel to channel	2000 Vac		
	Channel to protective earth (PE)	2000 Vac		
Resistance of insulation	Channel to X-bus	>10 MΩ		

(at 500 Vdc)	Channel to channel		>10 MΩ
Power supply consumption	3.3 V	Typical	40 mA
		Maximum	75 mA
	24 V ⁽¹²⁾	Typical	101 mA
		Maximum	137 mA
<p>(1): 0.04 x 10⁶ cycles, (2): 0.05 x 10⁶ cycles, (3): 0.06 x 10⁶ cycles, (4): 0.07 x 10⁶ cycles, (5): 0.1 x 10⁶ cycles, (6): 0.15 x 10⁶ cycles, (7): 0.2 x 10⁶ cycles, (8): 0.3 x 10⁶ cycles, (9): 0.5 x 10⁶ cycles, (10): 0.7 x 10⁶ cycles, (11): 1 x 10⁶ cycles, (12): All channels at 1, (13): Below 50 °C (122 °F)</p>			

Connecting the Module

At a Glance

The BMX DRA 0815 module is fitted with a removable 20-pin terminal block for the connection of eight relay output channels.

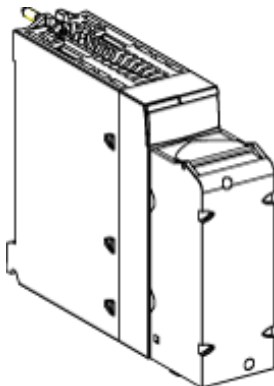

Output Circuit Diagram

The following diagram shows the circuit of a relay output.

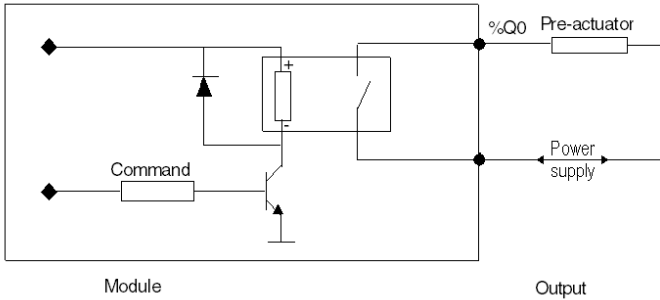

Module Connection

⚡ ⚠ DANGER

HAZARD OF ELECTRICAL SHOCK, EXPLOSION OR ARC FLASH

Switch off the sensor and pre-actuator voltage before connecting or disconnecting the module.

Failure to follow these instructions will result in death or serious injury.

⚠ CAUTION

LOSS OF OUTPUT FUNCTION

Install the correct rating and type of fuse.

Failure to follow these instructions can result in injury or equipment damage.

The following diagram shows the connection of the module to the pre-actuators.

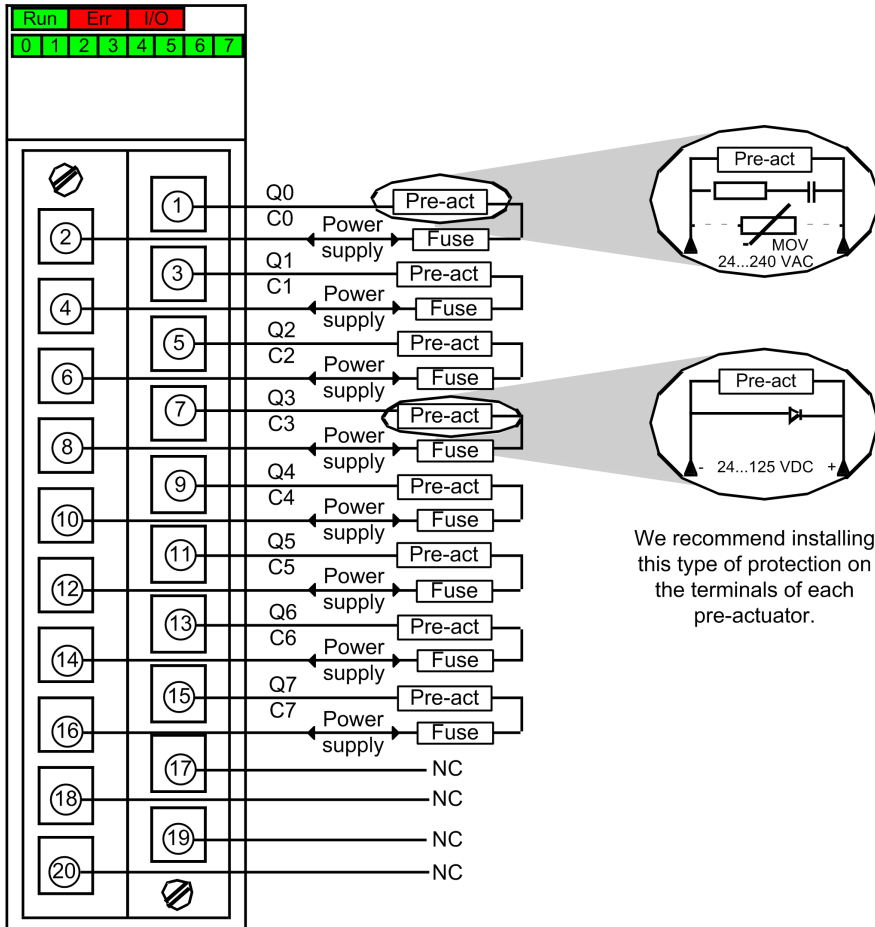

We recommend installing this type of protection on the terminals of each pre-actuator.

power supply: 24...125 VDC or 24...240 VAC

fuse: Use appropriate fast-blow fuse for each relay.

NC: not connected

BMX DRA 1605 Relay Output Modules

What's in This Chapter

Introduction	232
Characteristics.....	233
Connecting the Module	235

Subject of this Section

This section presents the BMX DRA 1605 module, its characteristics, and explains how it is connected to the pre-actuators.

Introduction

Function

The BMX DRA 1605 module is a 24 VDC or 24...240 VAC discrete module connected via a 20-pin terminal block. Its 16 non-isolated relay output channels operate either on alternating current or direct current.

Ruggedized Version

The BMX DRA 1605H (hardened) equipment is the ruggedized version of the BMX DRA 1605 (standard) equipment. It can be used at extended temperatures and in harsh chemical environments.

For more information, refer to chapter *Installation in More Severe Environments* (see Modicon M580, M340, and X80 I/O Platforms, Standards and Certifications).

Illustration

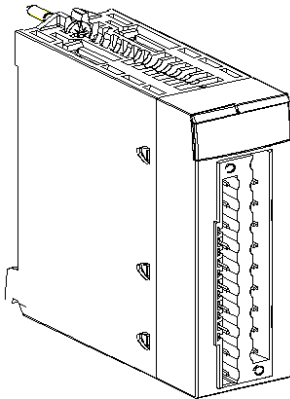

Characteristics

Altitude Operating Conditions

The characteristics in the table below apply to the modules BMX DRA 1605 and BMX DRA 1605H for use at altitude up to 2000 m (6560 ft). When the modules operate above 2000 m (6560 ft), apply additional derating.

For detailed information, refer to chapter *Operating and Storage Conditions* (see Modicon M580, M340, and X80 I/O Platforms, Standards and Certifications).

General Characteristics

This table presents the general characteristics for the BMX DRA 1605 and BMX DRA 1605H modules:

Module type		Relay outputs for alternating and direct current
Operating temperature	BMX DRA 1605	0...60 °C (32...140 °F)
	BMX DRA 1605H	-25...70 °C (-13...158 °F)
Rated voltage	Direct	24 VDC
	Alternating	24...240 VAC / 2 A, Cos ϕ = 1
Voltage range	Direct	24 VDC / 2 A (resistive load)
	Alternating	19...264 VAC / 2 A, Cos ϕ = 1
Minimum switching load		5 VDC / 1 mA.

Maximum switching load		264 VAC / 125 VDC			
Mechanical service life	Number of switching	20 million or more			
Alternating current load in resistive mode (AC12)	Voltage	24 VAC	48 VAC	100...120 VAC	200...240 VAC
	Power	50 VA ⁽²⁾	50 VA ⁽¹⁾ 80 VA ⁽²⁾	80 VA ⁽¹⁾ 200 VA ⁽²⁾	200 VA ⁽¹⁾
Alternating current load in inductive mode (AC15)	Voltage	24 VAC	48 VAC	100...120 VAC	200...240 VAC
	Power	36 VA ⁽¹⁾	36 VA ⁽¹⁾	36 VA ⁽¹⁾	36 VA ⁽¹⁾ Cos $\phi = 0,35$
		72 VA ⁽¹⁾	72 VA ⁽¹⁾	72 VA ⁽¹⁾	72 VA ⁽¹⁾ Cos $\phi = 0,7$
		120 VA ⁽²⁾	120 VA ⁽²⁾	120 VA ⁽²⁾	120 VA ⁽²⁾ Cos $\phi = 0,35$ 240 VA ⁽²⁾ Cos $\phi = 0,7$
Direct current load in resistive mode (DC12)	Voltage	24 VDC		48 VDC	
	Power	24 W ⁽²⁾		24 W ⁽⁴⁾	
Direct current load in inductive mode (DC13)	Voltage	24 VDC		48 VDC	
	Power (L/R = 7 ms)	3 W ⁽¹⁾		3 W ⁽¹⁾	
		10 W ⁽²⁾		10 W ⁽²⁾	
Power (L/R = 20 ms)	24 W ⁽³⁾		24 W ⁽³⁾		
Response time	Activation	< 8 ms			
	Deactivation	< 10 ms			
On-line module change		Possible			
Built-in protection	Against alternating current inductive over voltage	None. Fit an RC circuit or a ZNO type over voltage limiter in parallel on each output appropriate to the voltage in use.			
	Against direct current inductive over voltage	None. Fit a discharge diode on each output.			
	Against short-circuits and overloads	None. Fit a fast-blow fuse of 12 A for each 8-channel group.			
Maximum switching frequency		3 600 cycles per hour			
Power dissipation		3 W max			
Dielectric strength (at 50/60 Hz for 1 min.)		2000 V actual			

Resistance of insulation (at 500 VDC)		> 10 MΩ	
Noise immunity		In noise simulation below 1500 V actual, noise width of 1s and frequency of 25 to 60 Hz	
Reliability	MTBF for continuous operation in hours at ambient temperature 30°C (86°F)	1 357 810	
Power supply consumption	3.3 V	Typical	79 mA
		Maximum	111 mA
	24 V relay ⁽⁵⁾	Typical	89 mA
		Maximum	100 mA
(1): 3 x 10 ⁵ cycles, (2): 1 x 10 ⁵ cycles, (3): 7 x 10 ³ cycles, (4): 5 x 10 ⁴ cycles, (5): per channel at 1.			

NOTE: For the **BMX DRA 1605H** module, the maximum power must not exceed 24 VA per channel when operated at 70 °C (158 °F).

Connecting the Module

At a Glance

The BMX DRA 1605 module is fitted with a removable 20-pin terminal block for the connection of sixteen non-isolated relay output channels.

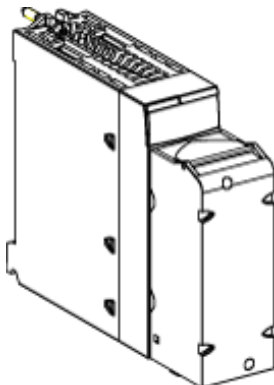

Output Circuit Diagram

The following diagram shows the circuit of relay outputs.

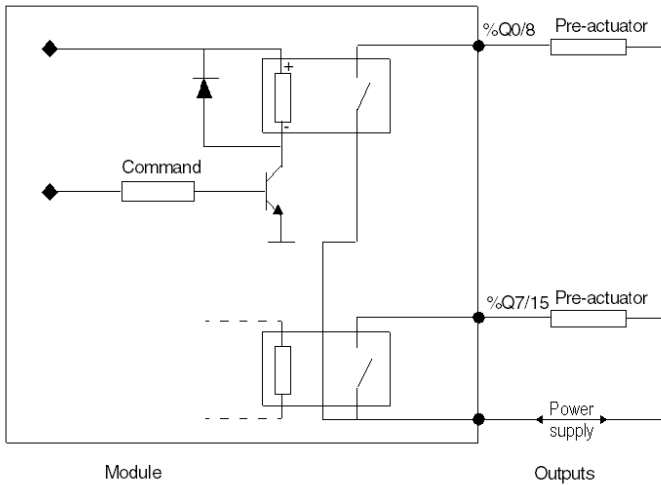

Module Connection

⚡ ⚠ DANGER

HAZARD OF ELECTRICAL SHOCK, EXPLOSION OR ARC FLASH

Switch off the sensor and pre-actuator voltages before connecting or disconnecting the module.

Failure to follow these instructions will result in death or serious injury.

⚠ CAUTION

LOSS OF OUTPUT FUNCTION

Install the correct rating and type of fuse.

Failure to follow these instructions can result in injury or equipment damage.

The following diagram shows the connection of the module to the pre-actuators.

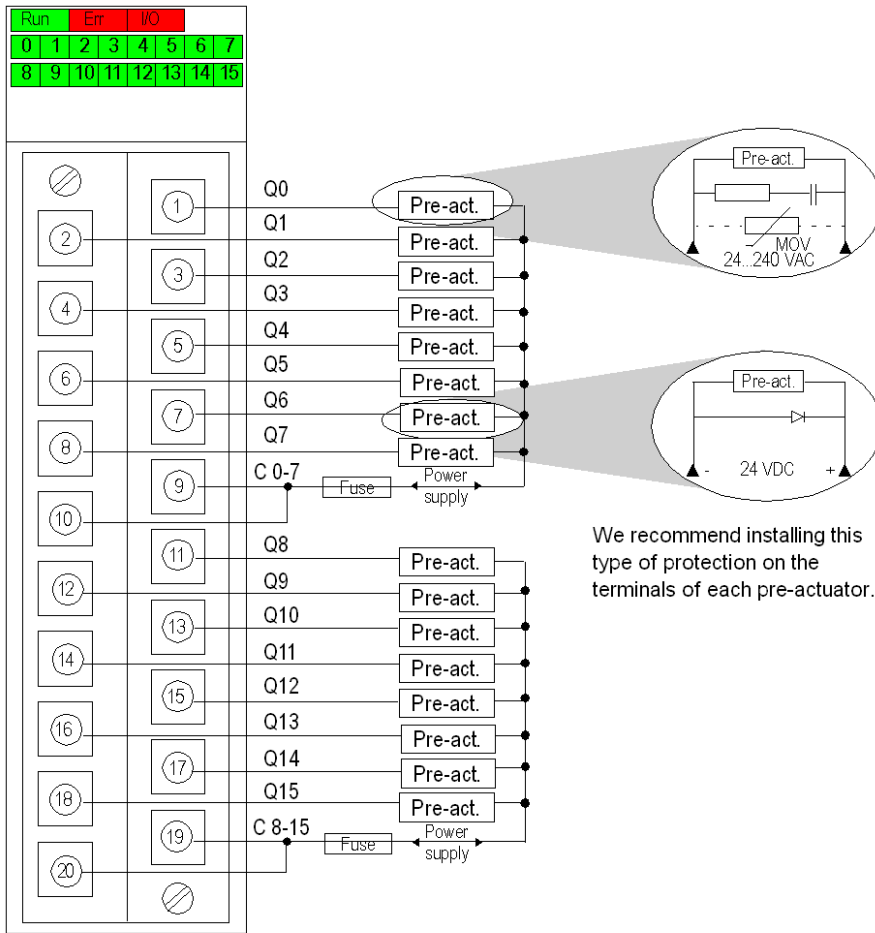

We recommend installing this type of protection on the terminals of each pre-actuator.

power supply: 24 VDC or 24...240 VAC

fuse: 1 fast blow fuse of 12 A for each 8-channel group

BMX DRC 0805 Relay Output Modules

What's in This Chapter

Introduction	238
Characteristics.....	239
Connecting the Module	242

Subject of this Section

This section presents the BMX DRC 0805 module, its characteristics, and explains how it is connected to the pre-actuators.

Introduction

Function

The BMX DRC 0805 module is a 5...125 Vdc or 24...240 Vac discrete module connected via a 40-pin terminal block. Its 8 relay output channels (NO/NC) operate either on alternating current or direct current.

Ruggedized Version

The BMX DRC 0805H (hardened) equipment is the ruggedized version of the BMX DRC 0805 (standard) equipment. It can be used at extended temperatures and in harsh chemical environments.

For more information, refer to chapter *Installation in More Severe Environments* (see Modicon M580, M340, and X80 I/O Platforms, Standards and Certifications).

Illustration

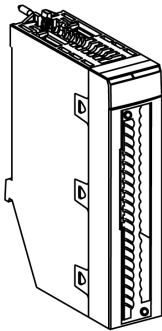

Characteristics

Altitude Operating Conditions

The characteristics in the table below apply to the modules BMX DRC 0805 and BMX DRC 0805H for use at altitude up to 2000 m (6560 ft). When the modules operate above 2000 m (6560 ft), apply additional derating.

For detailed information, refer to chapter *Operating and Storage Conditions* (see Modicon M580, M340, and X80 I/O Platforms, Standards and Certifications).

General Characteristics

This table presents the general characteristics for the BMX DRC 0805 and BMX DRC 0805H modules:

Module type	NO/NC relay outputs for alternating and direct current	
Rated range	Alternating	24...240 Vac
	Direct	24...125 Vdc
Voltage range	Alternating	19...264 Vac (47...63 Hz)
	Direct	5...150 Vdc
Operating temperature	BMX DRC 0805	0 °C to 60 °C (32 °F to 140 °F) with derating (see hereafter).
	BMX DRC 0805H	-25 °C to 70 °C (-13 °F to 158 °F) with derating (see hereafter).

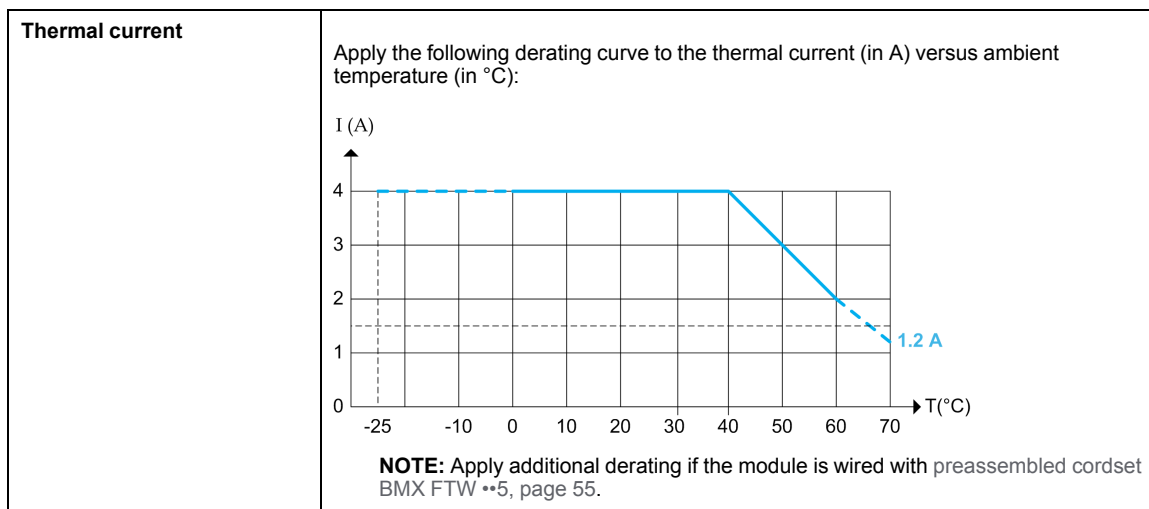

Minimum switching load		5 Vdc / 10 mA			
Alternating current load in resistive mode (AC12)	Voltage	24 Vac	48 Vac	100...120 Vac	200...250 Vac
	Switching power below 60 °C (140 °F)	48 VA ⁽⁷⁾	48 VA ⁽⁸⁾ 96 VA ⁽⁶⁾	110 VA ⁽⁸⁾ 220 VA ⁽⁶⁾	220 VA ⁽⁸⁾ 500 VA ⁽⁶⁾
	Maximum switching power of hardened module at 60...70 °C (140...158 °F)	28.8 VA ⁽⁷⁾	28.8 VA ⁽⁸⁾ 57.6 VA ⁽⁶⁾	66 VA ⁽⁸⁾ 132 VA ⁽⁶⁾	132 VA ⁽⁸⁾ 300 VA ⁽⁶⁾
Alternating current load in inductive mode (AC15) (Power factor = 0.4)	Voltage	24 Vac	48 Vac	100...120 Vac	200...250 Vac
	Switching power below 60 °C (140 °F)	10 VA ⁽¹⁰⁾ 24 VA ⁽⁹⁾ 48 VA ⁽⁶⁾ 72 VA ⁽⁴⁾⁽¹³⁾	10 VA ⁽¹⁰⁾ 24 VA ⁽⁹⁾ 48 VA ⁽⁸⁾ 96 VA ⁽⁵⁾ 144 VA ⁽³⁾⁽¹³⁾	10 VA ⁽¹¹⁾ 50 VA ⁽⁸⁾ 110 VA ⁽⁷⁾ 220 VA ⁽⁴⁾ 360 VA ⁽²⁾⁽¹³⁾	10 VA ⁽¹¹⁾ 50 VA ⁽⁹⁾ 110 VA ⁽⁷⁾ 220 VA ⁽⁶⁾ 500 VA ⁽³⁾ 750 VA ⁽¹⁾⁽¹³⁾
	Maximum switching power of hardened module at 60...70 °C (140...158 °F)	6 VA ⁽¹⁰⁾ 14.4 VA ⁽⁹⁾ 28.8 VA ⁽⁶⁾	6 VA ⁽¹⁰⁾ 14.4 VA ⁽⁹⁾ 28.8 VA ⁽⁸⁾ 57.6 VA ⁽⁵⁾	6 VA ⁽¹¹⁾ 30 VA ⁽⁸⁾ 66 VA ⁽⁷⁾ 132 VA ⁽⁴⁾	6 VA ⁽¹¹⁾ 30 VA ⁽⁹⁾ 66 VA ⁽⁷⁾ 132 VA ⁽⁶⁾ 300 VA ⁽³⁾

Direct current load in resistive mode (DC12) (L:R = 1 ms)	Voltage	24 Vdc	48...60 Vdc	100...125 Vdc
	Switching power below 60 °C (140 °F)	24 W ⁽⁷⁾ 48 W ⁽⁶⁾	40 W ⁽⁶⁾	45 W ⁽⁵⁾
	Maximum switching power of hardened module at 60...70 °C (140...158 °F)	14.4 W ⁽⁷⁾ 28.8 W ⁽⁶⁾	24 W ⁽⁶⁾	45 W ⁽³⁾
Direct current load in inductive mode (DC13) (L:R = 15 ms)	Voltage	24 Vdc	48...60 Vdc	110...125 Vdc
	Switching power below 60 °C (140 °F)	10 W ⁽⁵⁾ 24 W ⁽³⁾ 48 W ⁽¹⁾	40 W ⁽¹⁾	15 W ⁽⁵⁾
	Maximum switching power of hardened module at 60...70 °C (140...158 °F)	6 W ⁽⁵⁾ 14.4 W ⁽³⁾ 28.8 W ⁽¹⁾	24 W ⁽¹⁾	15 W ⁽¹⁾
Mechanical operations		20,000,000 minimum		
Response time	Activation (to NO)	<10 ms		
	Deactivation (to NC)	<13 ms		
Surge current maximum	10 A capacitive	t = 10 ms		
Built-in protection	Against inductive over voltage in AC modes	None. Fit an RC circuit or a ZNO type over voltage limiter in parallel on each output channel appropriate to the voltage in use.		
	Against inductive over voltage in DC modes	None. Fit a discharge diode on each output channel.		
	Against short-circuits and overloads	None. Fit a fast-blow fuse on each output channel or channel group. NOTE: The current capability of fuse depends on the maximum switching load.		
Reliability	MTBF for continuous operation in hours at ambient temperature 30 °C (86 °F)	2,683,411		
Power dissipation⁽¹²⁾		3.6 W + 0.03 x (I1 ² + I2 ² + ...+ I8 ²) Where I1, I2,.....I8 is the load current for each channel.		
Dielectric strength (at 50/60 Hz for 1 min.)	Channel to X-bus	3000 Vac		
	Channel to channel	2000 Vac		
	Channel to protective earth (PE)	2000 Vac		

Resistance of insulation (at 500 Vdc)	Channel to X-bus		>10 MΩ
	Channel to channel		>10 MΩ
Power supply consumption	3.3 V	Typical	40 mA
		Maximum	75 mA
	24 V ⁽¹²⁾	Typical	101 mA
		Maximum	137 mA

(1): 0.04 x 10⁶ cycles, (2): 0.05 x 10⁶ cycles, (3): 0.06 x 10⁶ cycles, (4): 0.07 x 10⁶ cycles,
 (5): 0.1 x 10⁶ cycles, (6): 0.15 x 10⁶ cycles, (7): 0.2 x 10⁶ cycles, (8): 0.3 x 10⁶ cycles,
 (9): 0.5 x 10⁶ cycles, (10): 0.7 x 10⁶ cycles, (11): 1 x 10⁶ cycles,
 (12): All channel at 1, (13): Below 50 °C (122 °F)

Connecting the Module

At a Glance

The BMX DRC 0805 module is fitted with a removable 40-pin terminal block for the connection of eight relay output channels.

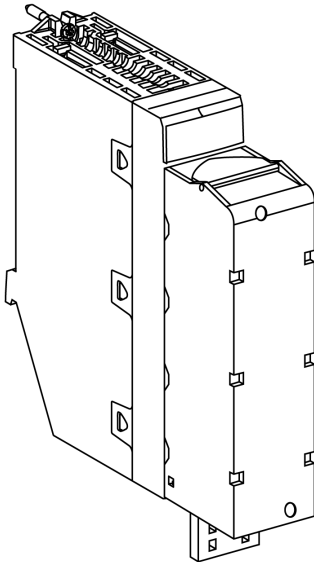

Output Circuit Diagram

The following diagram shows the circuit of a relay output.

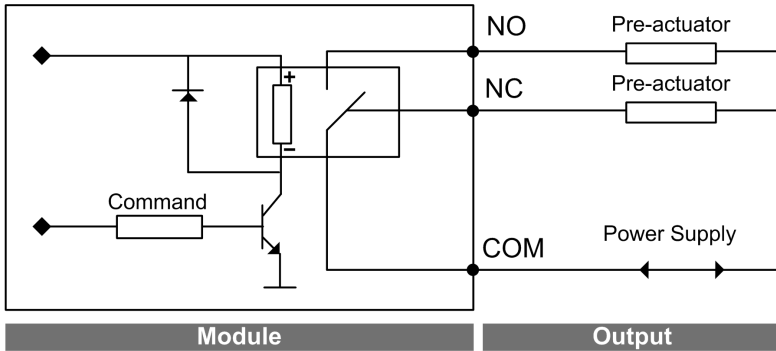

NO: Normally open output

NC: Normally closed output

Module Connection

⚡ ⚠ DANGER

HAZARD OF ELECTRICAL SHOCK, EXPLOSION OR ARC FLASH

Switch off the sensor and pre-actuator voltage before connecting or disconnecting the module.

Failure to follow these instructions will result in death or serious injury.

⚠ CAUTION

LOSS OF OUTPUT FUNCTION

Install the correct rating and type of fuse.

Failure to follow these instructions can result in injury or equipment damage.

The following diagram shows the connection of the module to the pre-actuators.

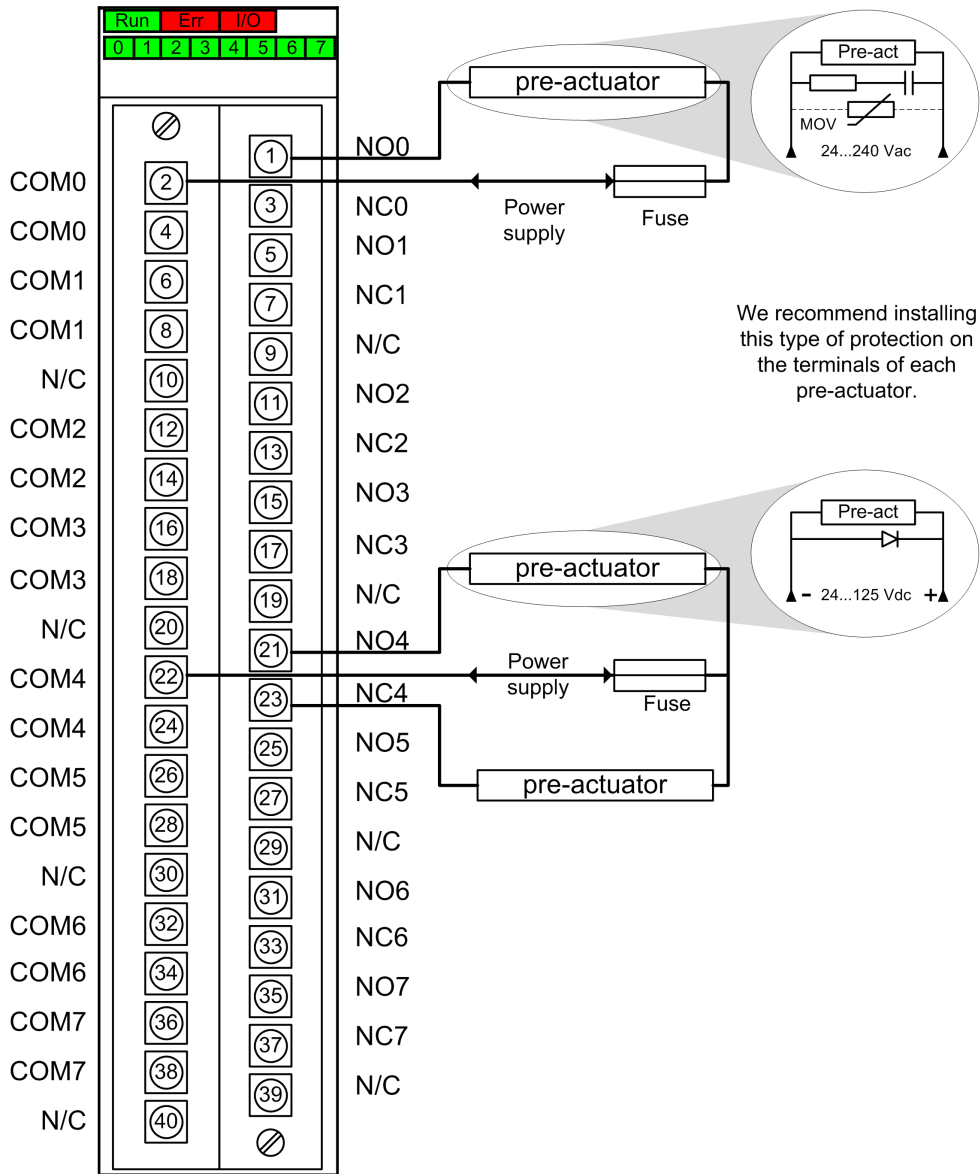

Power supply: 24...125 Vdc or 24...240 Vac

Fuse: Use appropriate fast-blow fuse for each relay.

N/C: Not connected

BMX DDO 3202 K Static Output Modules

What’s in This Chapter

Introduction	245
Characteristics.....	246
Connecting the Module	248

Subject of this Section

This section presents the BMX DDO 3202 K module, its characteristics, and explains how it is connected to the pre-actuators.

Introduction

Function

The BMX DDO 3202 K module is a 24 VDC discrete module connected via a 40-pin connector. It is a positive logic (or source) module: its 32 output channels provide current to the pre-actuators.

Ruggedized Version

The BMX DDO 3202 KC (coated) equipment is the ruggedized version of the BMX DDO 3202 K (standard) equipment. It can be used in harsh chemical environments.

For more information, refer to chapter *Installation in More Severe Environments* (see Modicon M580, M340, and X80 I/O Platforms, Standards and Certifications).

Illustration

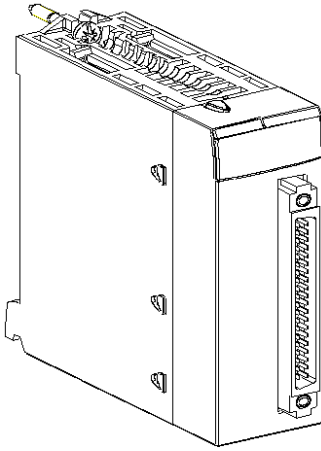

Characteristics

Altitude Operating Conditions

The characteristics in the table below apply to the modules BMX DDO 3202 K and BMX DDO 3202 KC for use at altitude up to 2000 m (6560 ft). When the modules operate above 2000 m (6560 ft), apply additional derating.

For detailed information, refer to chapter *Operating and Storage Conditions* (see Modicon M580, M340, and X80 I/O Platforms, Standards and Certifications).

General Characteristics

This table presents the general characteristics for the BMX DDO 3202 K and BMX DDO 3202 KC modules:

Module type		24 VDC positive logic static outputs
Operating temperature		0...60 °C (32...140 °F)
Temperature derating		Apply the temperature derating curve , page 34
Nominal values	Voltage	24 VDC
	Current	0.1 A
Threshold values	Voltage (including ripple)	19...30 V (34 V possible for 1 hour/day)

	Current/channel	0.125 A
	Current/module	3.2 A
Power of tungsten filament lamp	Maximum	1.2 W
Leakage current	At 0	100 µA for U = 30 V
Voltage drop	At 1	< 1.5 V for I = 0.1 A
Load impedance	Minimum	220 Ω
Response time⁽¹⁾		1.2 ms
Max. overload time before internal damage		15 ms
Reliability	MTBF for continuous operation in hours at ambient temperature 30 °C (86 °F)	312 254
Frequency of switching to inductive load		0.5 / LI ² Hz
Paralleling of outputs		Yes (maximum of 3)
Compatibility with IEC 61131-2 DC direct inputs		Yes (type 3 or no type)
Built-in protection	Against overvoltage	Yes, by Transil diode
	Against inversions	Yes, by inverted diode ⁽²⁾
	Against short-circuits and overloads	Yes, by current limiter and electric circuit-breaker 0.125 A < I _d < 0.185 A
Fuse type	Internal	None
	External	1 fast blow fuse of 2 A for each 16-channel group
Pre-actuator voltage: monitoring threshold	OK	> 18 V
	Error	< 14 V
Pre-actuator voltage: monitoring response time	On appearance	8 ms < T < 30 ms
	On disappearance	1 ms < T < 3 ms
Power consumption 3.3 V	Typical	125 mA
	Maximum	166 mA
24 V pre-actuator consumption (excluding load current)	Typical	46 mA
	Maximum	64 mA
Power dissipation		3.6 W max.
Dielectric strength	Output / ground or output / internal logic	1500 V actual, 50 / 60 Hz for 1 min

	Between channel groups	500 VDC
Resistance of insulation		>10 M Ω (below 500 VDC)
(1) All outputs are equipped with fast demagnetization circuits for electromagnet. Electromagnet discharge time < L/R.		
(2) Provide a fuse to the +24 V pre-actuator supply		

Connecting the Module

At a Glance

The BMX DDO 3202 K module is fitted with a 40-pin connector for the connection of thirty-two output channels.

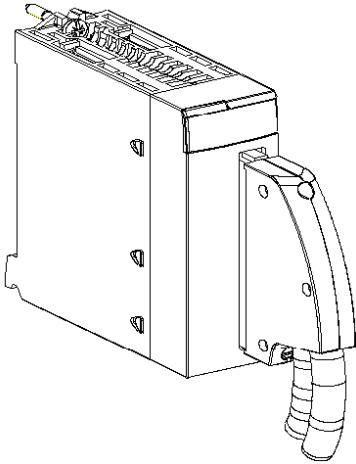

Output Circuit Diagram

The following diagram shows the circuit of a direct current output (positive logic).

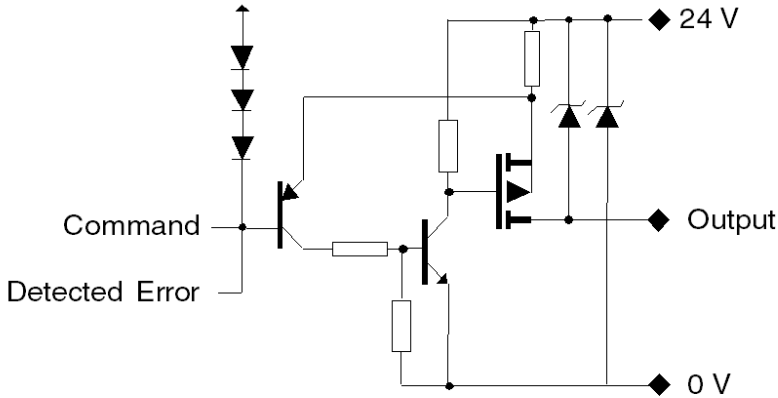

Module Connection

⚡ ⚠ DANGER

HAZARD OF ELECTRICAL SHOCK, EXPLOSION OR ARC FLASH

Switch off the sensor and pre-actuator voltage before connecting or disconnecting the module.

Failure to follow these instructions will result in death or serious injury.

⚠ CAUTION

LOSS OF INPUT FUNCTION

Install the correct rating and type of fuse.

Failure to follow these instructions can result in injury or equipment damage.

The diagram below shows the connection of the module to the pre-actuators.

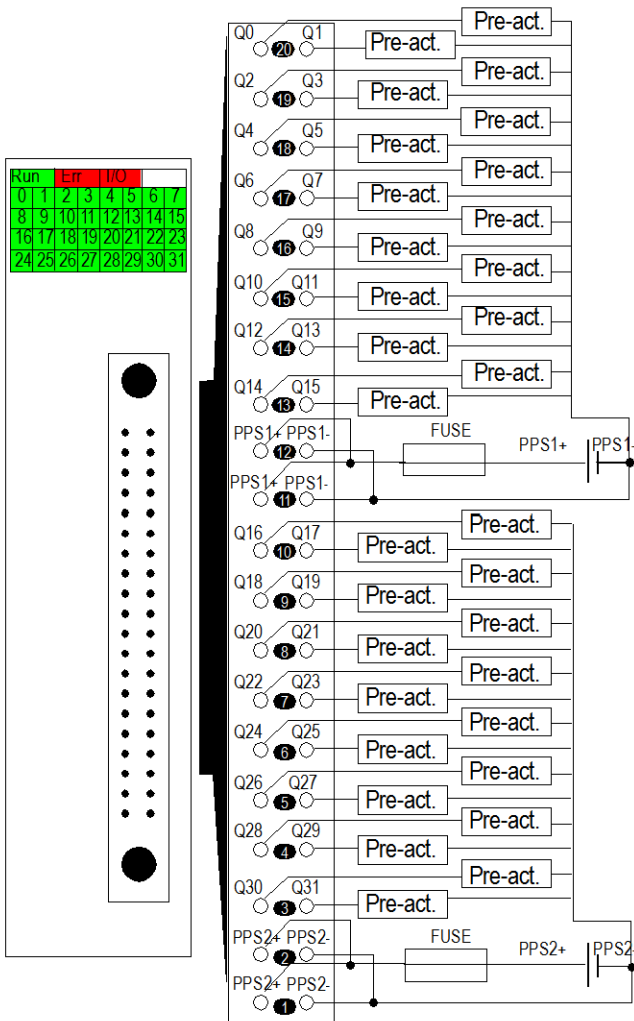

BMX DDO 6402 K Static Output Modules

What's in This Chapter

Introduction	251
Characteristics.....	252
Connecting the Module	254

Subject of this Section

This section presents the BMX DDO 6402 K module, its characteristics, and explains how it is connected to the pre-actuators.

Introduction

Function

The BMX DDO 6402 K module is a 24 VDC discrete module connected via two 40-pin connectors. It is a positive logic (or source) module: its 64 output channels provide current to the pre-actuators.

Ruggedized Version

The BMX DDO 6402 KC (coated) equipment is the ruggedized version of the BMX DDO 6402 K (standard) equipment. It can be used in harsh chemical environments.

For more information, refer to chapter *Installation in More Severe Environments* (see Modicon M580, M340, and X80 I/O Platforms, Standards and Certifications).

Illustration

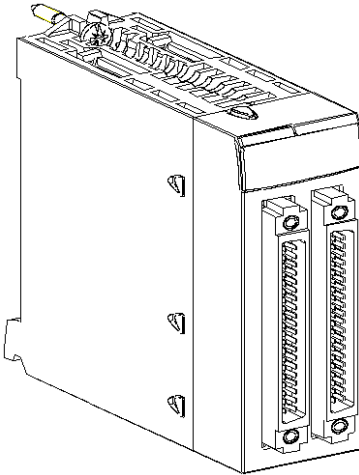

Characteristics

Altitude Operating Conditions

The characteristics in the table below apply to the modules BMX DDO 6402 K and BMX DDO 6402 KC for use at altitude up to 2000 m (6560 ft). When the modules operate above 2000 m (6560 ft), apply additional derating.

For detailed information, refer to chapter *Operating and Storage Conditions* (see Modicon M580, M340, and X80 I/O Platforms, Standards and Certifications).

General Characteristics

This table presents the general characteristics for the BMX DDO 6402 K and BMX DDO 6402 KC modules:

Module type		24 VDC positive logic static outputs
Operating temperature		0...60 °C (32...140 °F)
Temperature derating		Apply the temperature derating curve , page 34
Nominal values	Voltage	24 VDC
	Current	0.1 A
Threshold values	Voltage (including ripple)	19...30 V (34 V possible for 1 hour/day)

	Current/channel	0.125 A
	Current/module	6.4 A
Power of tungsten filament lamp	Maximum	1.2 W
Leakage current	At 0	100 μ A for U = 30 V
Voltage drop	At 1	< 1.5 V for I = 0.1 A
Load impedance	Minimum	220 Ω
Response time⁽¹⁾		1.2 ms
Max. overload time before internal damage		15 ms
Reliability	MTBF for continuous operation in hours at ambient temperature 30 °C (86 °F)	159 924
Frequency of switching to inductive load		0.5 / LI ² Hz
Paralleling of outputs		Yes (maximum of 3)
Compatibility with IEC 61131-2 DC direct inputs		Yes (type 3 and no type)
Built-in protection	Against over voltage	Yes, by Transil diode
	Against inversions	Yes, by inverted diode ⁽²⁾
	Against short-circuits and overloads	Yes, by current limiter and electric circuit-breaker 0.125 A < I _d < 0.185 A
Fuse type	Internal	None
	External	1 fast blow fuse of 2 A for each 16-channel group
Pre-actuator voltage: monitoring threshold	OK	> 18 V
	Error	< 14 V
Pre-actuator voltage: monitoring response time	On appearance	8 ms < T < 30 ms
	On disappearance	1 ms < T < 3 ms
Power consumption 3.3 V	Typical	160 mA
	Maximum	226 mA
24 V pre-actuator consumption (excluding load current)	Typical	92 mA
	Maximum	127 mA
Power dissipation		6.85 W max.
Dielectric strength	Output / ground or output / internal logic	1500 V actual, 50 / 60 Hz for 1 min
	Between channel groups	500 VDC

Resistance of insulation	>10 M Ω (below 500 VDC)
(1) All outputs are equipped with fast demagnetization circuits for electromagnet. Electromagnet discharge time < L/R.	
(2) Provide a 2 A fuse to the +24 V pre-actuator supply.	

Connecting the Module

At a Glance

The BMX DDO 6402 K module is fitted with two 40-pin connectors for the connection of sixty-four output channels.

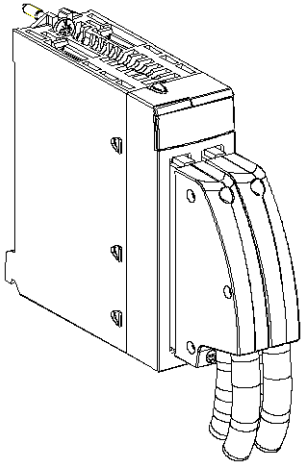

Output Circuit Diagram

The following diagram shows the circuit of a direct current output (positive logic).

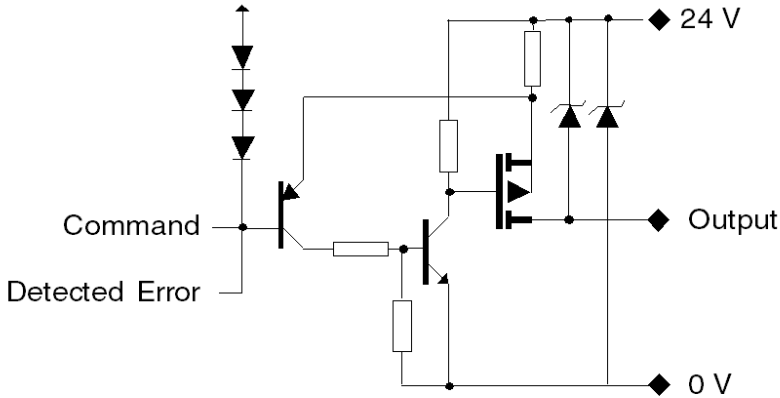

Module Connection

⚡ ⚠ DANGER

HAZARD OF ELECTRICAL SHOCK, EXPLOSION OR ARC FLASH

Switch off the sensor and pre-actuator voltage before connecting or disconnecting the module.

Failure to follow these instructions will result in death or serious injury.

⚠ CAUTION

LOSS OF INPUT FUNCTION

Install the correct rating and type of fuse.

Failure to follow these instructions can result in injury or equipment damage.

The diagram below shows the connection of the module to the pre-actuators.

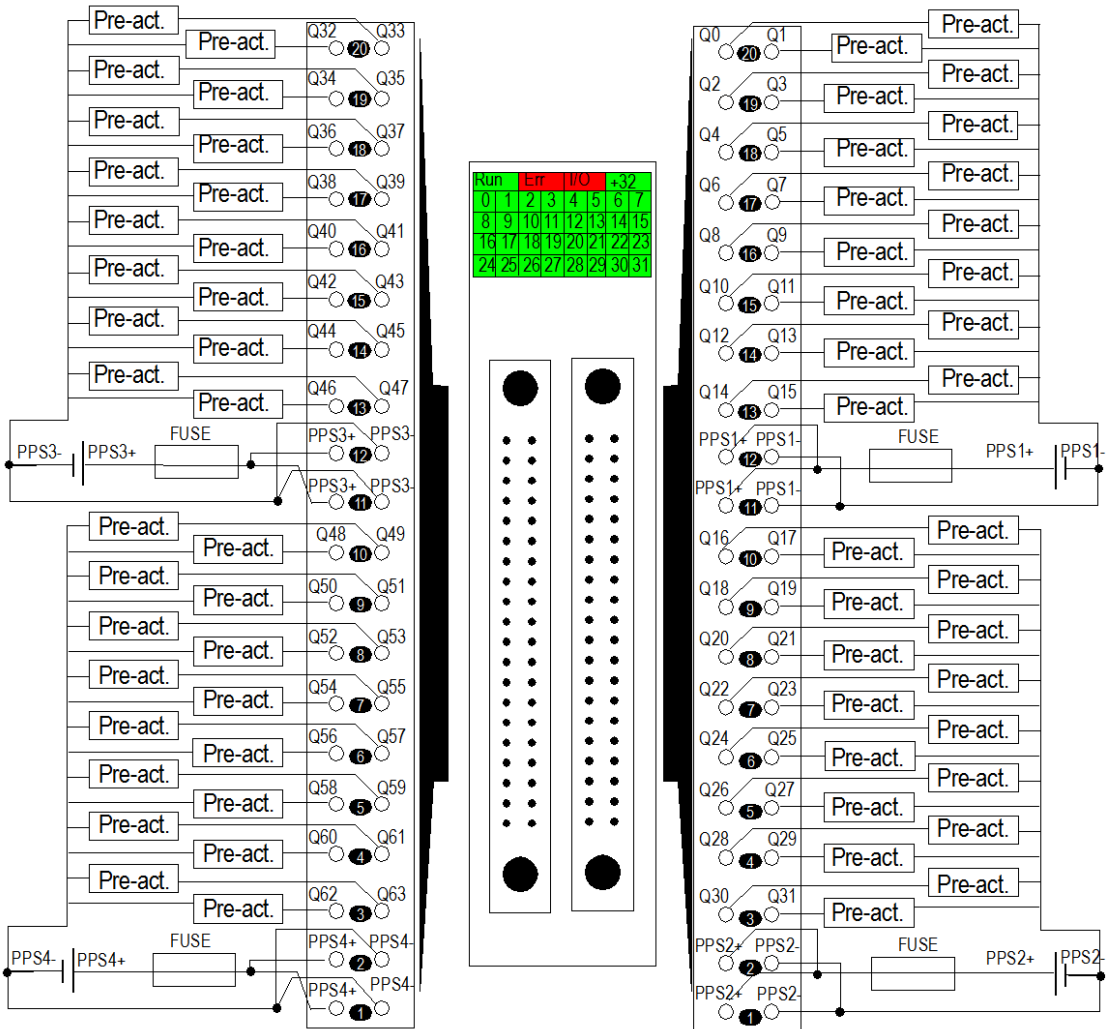

power supply: 24 VDC

fuse: fast blow fuse of 2 A for each 16-channel group

pre-act: pre-actuator

PPS: pre-actuator power supply

BMX DAO 1605 Triac Output Modules

What's in This Chapter

Introduction	257
Characteristics.....	258
Connecting the Module	260

Subject of this Section

This section presents the BMX DAO 1605 module, its characteristics, and explains how it is connected to the pre-actuators.

Introduction

Function

The BMX DAO 1605 module is a 100...240 VAC discrete module connected via a 20-pin terminal block. Its 16 triac output channels operate on alternating current.

Ruggedized Version

The BMX DAO 1605H (hardened) equipment is the ruggedized version of the BMX DAO 1605 (standard) equipment. It can be used at extended temperatures and in harsh chemical environments.

For more information, refer to chapter *Installation in More Severe Environments* (see Modicon M580, M340, and X80 I/O Platforms, Standards and Certifications).

Illustration

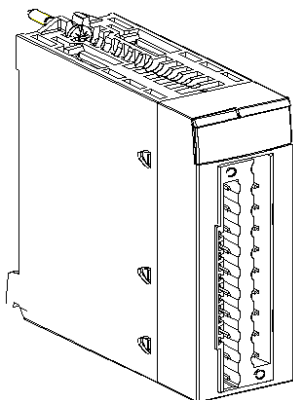

Characteristics

Altitude Operating Conditions

The characteristics in the table below apply to the modules BMX DAO 1605 and BMX DAO 1605H for use at altitude up to 2000 m (6560 ft). When the modules operate above 2000 m (6560 ft), apply additional derating.

For detailed information, refer to chapter *Operating and Storage Conditions* (see Modicon M580, M340, and X80 I/O Platforms, Standards and Certifications).

General Characteristics

This table presents the general characteristics for the BMX DAO 1605 and BMX DAO 1605H modules:

Module type		100...240 VAC triac outputs
Operating temperature	BMX DAO 1605	0...60 °C (32...140 °F)
	BMX DAO 1605H	-25...70 °C (-13...158 °F)
Temperature derating		Apply the temperature derating curve , page 34
Nominal values	Voltage	100...240 VAC
	Current	0.6 A / points
Threshold values	Voltage	100 mA at 24 VAC 25 mA at 100...240 VAC

	Current/channel	0.6 A
	Current/module	2.4 A max/common (4.8 A max for all commons)
Maximum inrush current		20 A / cycle or less
Leakage current	At state 0	≤ 3 mA (for 240 VAC, 60 Hz) ≤ 1.5 mA (for 120 VAC, 60 Hz)
	At state 1	≤ 1.5 VAC
Response time		≤ 1 ms + 1/(2xF)
Built-in protection	Against inductive over voltage in AC modes	None. Fit an RC circuit or a ZNO type over voltage limiter in parallel on each output appropriate to the voltage in use
	Against inductive over voltage	None. Fit a discharge diode on each output.
	against short-circuits and overloads	None. Fit a fast-blow fuse of 3 A on each channel or 4-channel group.
Command type		Zero crossing
Output protection		no protection
Dielectric maximum voltage		2 830 VAC rms/1 min
Insulation resistance		≥ 10 MΩ (by insulation resistance meter)
Noise immunity		By noise simulator of noise voltage, 1 μs noise width and 1 500 Vp-p 25...60 Hz noise frequency
Power consumption 3.3 V	Typical	79 mA
	Maximum	111 mA

NOTE: For the BMX DAO 1605H module, at 70 °C (158 °F), the maximum threshold current must not exceed 0.24 A per channel and the maximum module current must not exceed 1.92 A.

Connecting the Module

At a Glance

The BMX DAO 1605 module is fitted with a removable 20-pin terminal block for the connection of sixteen triac output channels.

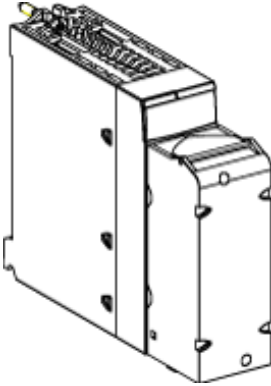

Output Circuit Diagram

The following diagram shows the circuit of a alternating current triac output.

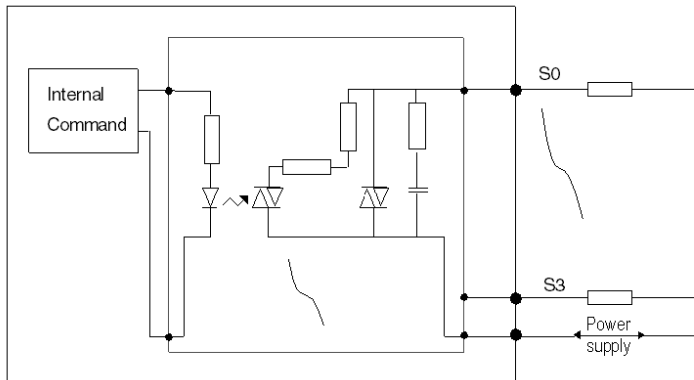

Module Connection

DANGER

HAZARD OF ELECTRICAL SHOCK, EXPLOSION OR ARC FLASH

Switch off the sensor and pre-actuator voltage before connecting or disconnecting the module.

Failure to follow these instructions will result in death or serious injury.

CAUTION

LOSS OF OUTPUT FUNCTION

Install the correct rating and type of fuse.

Failure to follow these instructions can result in injury or equipment damage.

The following diagram shows the connection of the module to the pre-actuators.

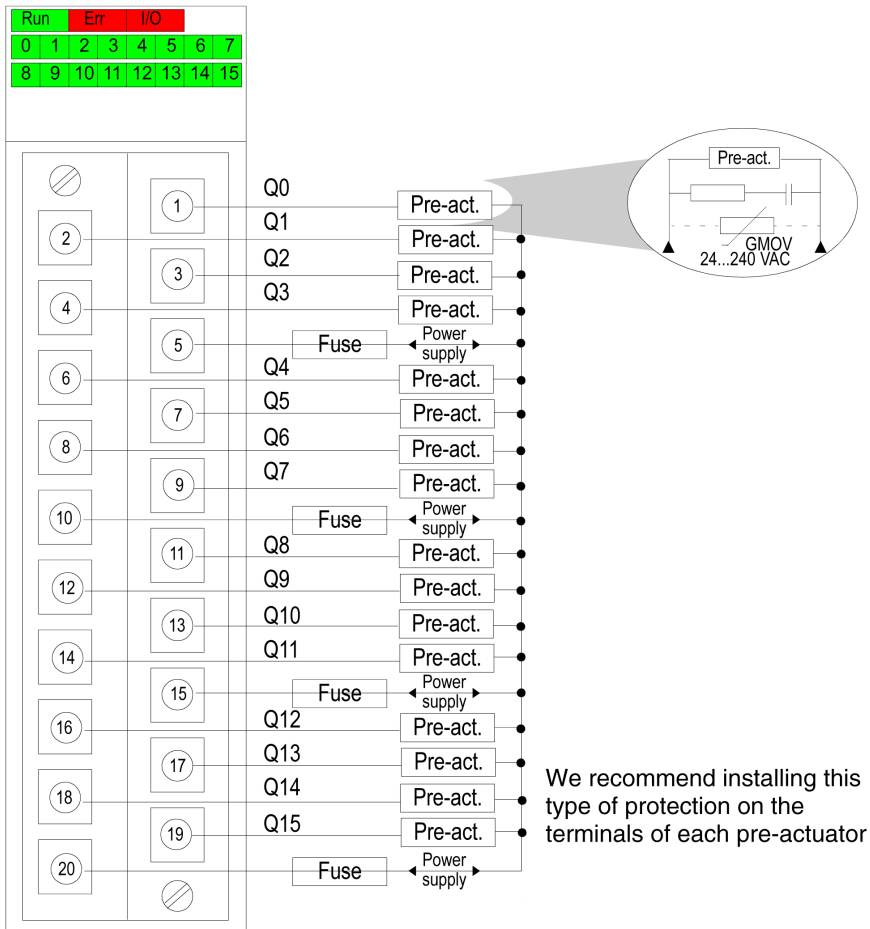

power supply: 100...240 VAC

fuse: 1 fast blow fuse of 3 A for each 4-channel group

BMX DAO 1615 Isolated Triac Output Modules

What’s in This Chapter

Introduction	263
Characteristics.....	264
Connecting the Module	267

Subject of this Section

This section presents the BMX DAO 1615 module, its characteristics, and explains how it is connected to the pre-actuators.

Introduction

Function

The BMX DAO 1615 module is a 24...240 Vac discrete module connected via a 40-pin terminal block. Its 16 isolated triac output channels operate on alternating current.

Ruggedized Version

The BMX DAO 1615H (hardened) equipment is the ruggedized version of the BMX DAO 1615 (standard) equipment. It can be used at extended temperatures and in harsh chemical environments.

For more information, refer to chapter *Installation in More Severe Environments* (see Modicon M580, M340, and X80 I/O Platforms, Standards and Certifications).

Illustration

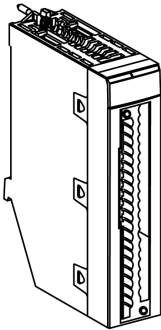

Characteristics

Altitude Operating Conditions

The characteristics in the table below apply to the modules BMX DAO 1615 and BMX DAO 1615H for use at altitude up to 2000 m (6560 ft). When the modules operate above 2000 m (6560 ft), apply additional derating.

For detailed information, refer to chapter *Operating and Storage Conditions* (see Modicon M580, M340, and X80 I/O Platforms, Standards and Certifications).

General Characteristics

⚠ CAUTION	
OVERHEATING HAZARD	
Take into account the temperature derating of the discrete I/O modules at the installation to prevent the device from overheating and/or deteriorating.	
Failure to follow these instructions can result in injury or equipment damage.	

This table presents the general characteristics for the BMX DAO 1615 and BMX DAO 1615H modules:

Module type		24...240 Vac16-channel Isolated Triac Output
Operating temperature	BMX DAO 1615	0...60 °C (32...140 °F)
	BMX DAO 1615H	-25...70 °C (-13...158 °F)

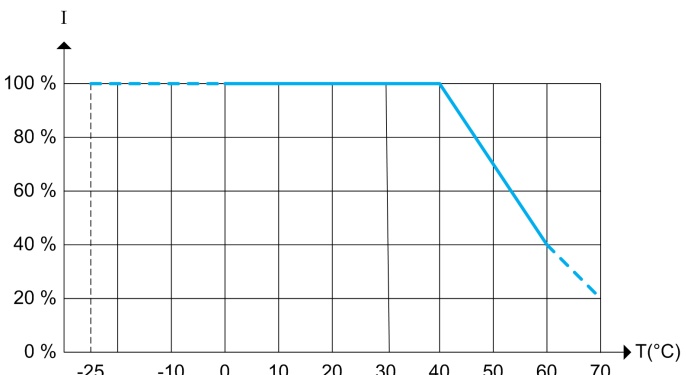
<p>Temperature derating</p>	<p>Apply the following derating curve (total module output current (in %) versus ambient temperature (in °C):</p>  <p>NOTE: The curves apply to the BMX DAO 1615 in the temperature range 0...60 °C (32 °F...140 °F) and apply to the BMX DAO 1615H in the temperature range -25...70 °C (-13...158 °F).</p>	
<p>Nominal values</p>	<p>Voltage</p>	<p>24...240 Vac</p>
	<p>Current</p>	<p>3 A per channel.</p>
<p>Operating range</p>	<p>Voltage</p>	<p>20...264 Vac</p>
	<p>Frequency</p>	<p>47...63 Hz</p>
<p>Voltage minimum and maximum</p>	<p>Voltage drop at state 1</p>	<p>≤ 1.55 Vac</p>
	<p>Maximum input voltage</p>	<p>300 Vac during 10 s 400 Vac during one cycle</p>
<p>Current minimum and maximum</p>	<p>Load current (minimum)</p>	<p>5 mA minimum.</p>
	<p>Current / 4 contiguous channels</p>	<p>4 A maximum continuous for the sum of the 4 channels.</p>
	<p>Current / module</p>	<p>10 A maximum continuous.</p>
	<p>Maximum inrush current (rms)</p>	<p>30 A per channel for 1 cycle. 20 A per channel for 2 cycles. 10 A per channel for 3 cycles.</p>
	<p>Leakage current at state 0</p>	<p>≤ 2.5 mA at 240 Vac ≤ 2 mA at 115 Vac ≤ 1 mA at 48 Vac ≤ 1 mA at 24 Vac</p>
<p>Response time</p>	<p>≤ 0.5 x (1/F)</p>	

Built-in protection	Against inductive over voltage		None. Fit an RC circuit or a ZNO type over voltage limiter in parallel on each pre-actuator appropriate to the voltage in use
	Against short-circuits and overloads		None. Fit a 4 A fast blow fuse on each channel.
Output protection (internal)			RC snubber suppression.
Dielectric strength	Channel to X-bus		1780 Vac, 50/60 Hz for 1 min.
	Channel to channel		1500 Vac, 50/60 Hz for 1 min.
Insulation Resistance	Channel to X-bus		>10 M Ω (below 500 Vdc)
	Channel to channel		>10 M Ω (below 500 Vdc)
Applied dV/dt			400 V/ μ s
Backplane consumption	24 V	Typical	50 mA
		Maximum	60 mA
	3.3 V	Typical	61 mA
		Maximum	87 mA

Connecting the Module

At a Glance

The BMX DAO 1615 module is fitted with a removable 40-pin terminal block for the connection of 16 triac isolated output channels.

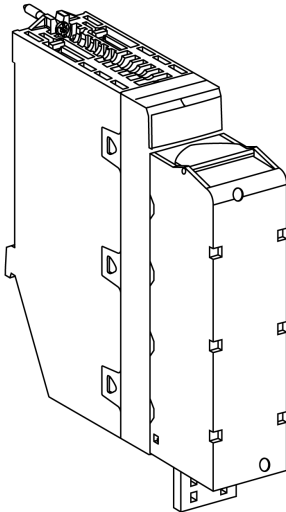

Output Circuit Diagram

The following diagram shows the circuit of an alternating current triac isolated output:

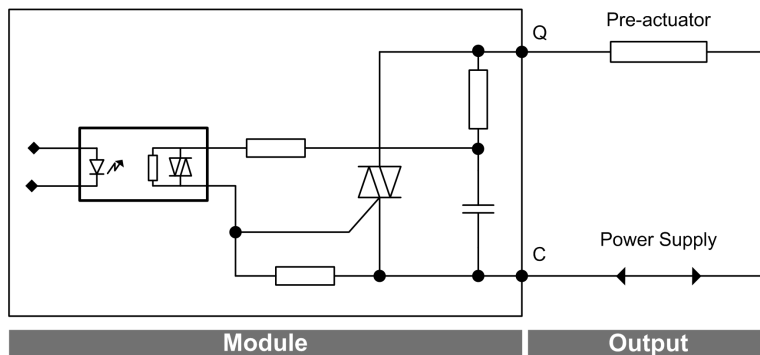

Module Connection

DANGER

HAZARD OF ELECTRICAL SHOCK, EXPLOSION OR ARC FLASH

Switch off the sensor and pre-actuator voltage before connecting or disconnecting the module.

Failure to follow these instructions will result in death or serious injury.

CAUTION

LOSS OF OUTPUT FUNCTION

Install the correct rating and type of fuse.

Failure to follow these instructions can result in injury or equipment damage.

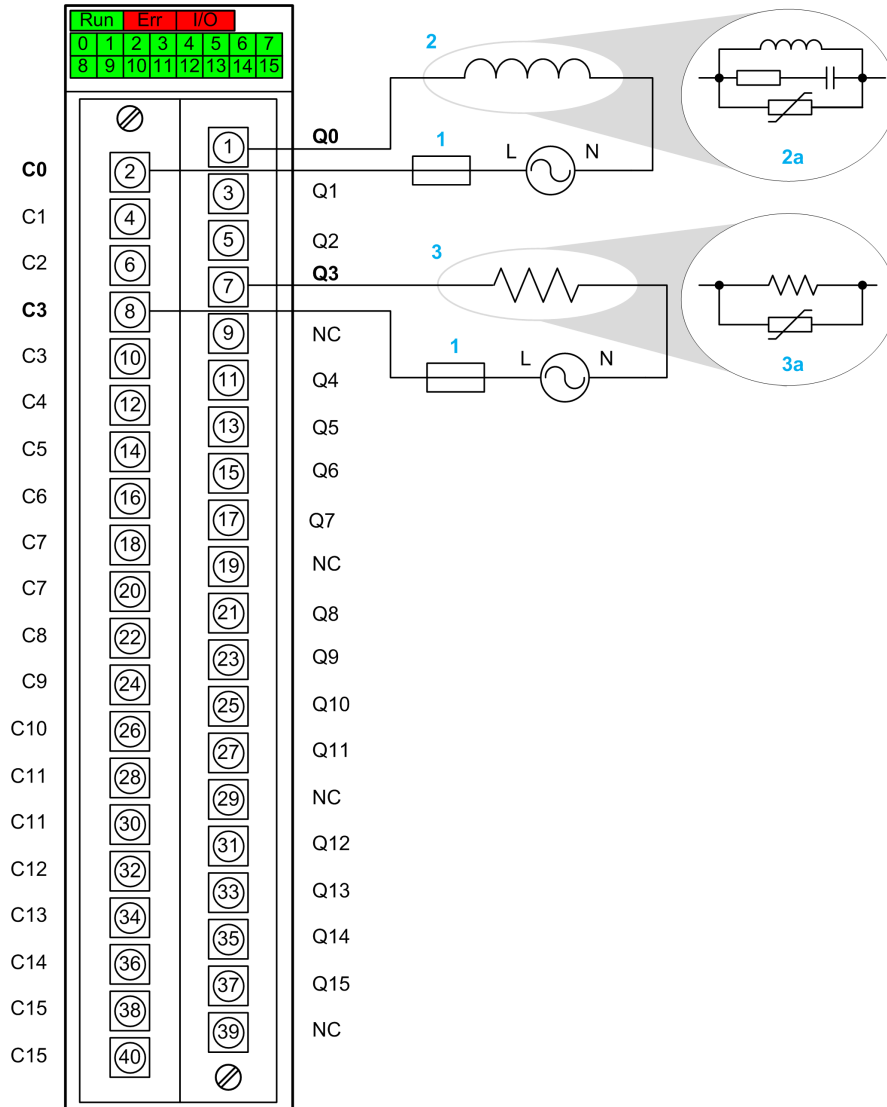

NC: Not connected.

1 4 A fast blow fuse.

2 Inductive load.

3 Resistive load.

2a and 3a Recommended output protection (see note below).

NOTE: The recommended output protection for both inductive and resistive load is composed of a varistor (GMOV 24...240 Vac). The electronic characteristics of the varistor depend on the voltage required by the device used.

For inductive load, an optional RC filter (snubber) is recommended in addition to the varistor. The values for the resistor and the capacitor depend on the device used.

Each terminal capacity is one wire 22...18 AWG (0,34...1 mm²). For more details, refer to *terminal block wiring capacity*, page 45.

Output Usage Rules

Usage of the outputs with different phases, is dependent on the power supply voltage:

- In the range of 24...133 Vac, adjacent channel outputs can be used.
- In the range of 133...240 Vac, the channel outputs used, need to be separated by an unused channel output (for example Q1 and Q2 with phase A, skip Q3, and Q4 with phase B).

CAUTION

DAMAGE TO MODULE OUTPUTS

- Ensure that the AC power energizing each group is from a common, single-phase AC power source.
- Protect the module output when an external switch is used to control an inductive load in parallel with the module output. Use an external varistor in parallel with the switch.

Failure to follow these instructions can result in injury or equipment damage.

BMX DDM 16022 Mixed Static Input/Output Module

What's in This Chapter

Introduction	271
Characteristics.....	272
Connecting the Module	276

Subject of this Section

This section presents the BMX DDM 16022 module, its characteristics, and explains how it is connected to the sensors and pre-actuators.

Introduction

Function

The BMX DDM 16022 module is a 24 VDC discrete module connected via a 20-pin terminal block. It is a positive logic module: its 8 input channels receive current from the sensors (sink) and its 8 output channels provide current to the pre-actuators (source).

Ruggedized Version

The BMX DDM 16022H (hardened) equipment is the ruggedized version of the BMX DDM 16022 (standard) equipment. It can be used at extended temperatures and in harsh chemical environments.

For more information, refer to chapter *Installation in More Severe Environments* (see Modicon M580, M340, and X80 I/O Platforms, Standards and Certifications).

Illustration

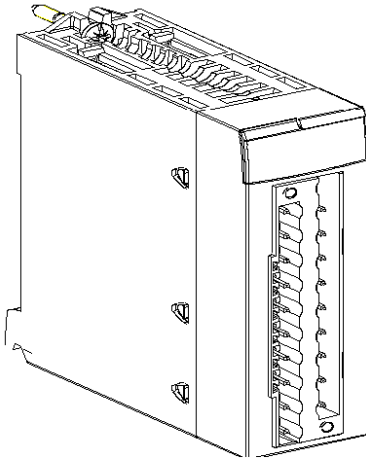

Characteristics

Altitude Operating Conditions

The characteristics in the tables below apply to the modules BMX DDM 16022 and BMX DDM 16022H for use at altitude up to 2000 m (6560 ft). When the modules operate above 2000 m (6560 ft), apply additional derating.

For detailed information, refer to chapter *Operating and Storage Conditions* (see Modicon M580, M340, and X80 I/O Platforms, Standards and Certifications).

General Input Characteristics

The following table shows the general input characteristics of the BMX DDM 16022 and BMX DDM 16022H modules:

Input module type		24 VDC positive logic inputs	
Operating temperature	BMX DDM 16022	0...60 °C (32...140 °F)	
	BMX DDM 16022H	-25...70 °C (-13...158 °F)	
Nominal input values	Voltage	24 VDC	
	Current	3.5 mA	
Threshold input values	At 1	Voltage	≥ 11 V

		Current	> 2 mA for $U \geq 11$ V
	At 0	Voltage	5 V
		Current	≤ 1.5 mA
	Sensor supply (including ripple)		19...30 V (possibly up to 34 V, limited to 1 hour/day)
Input impedance	At nominal U		6.8 k Ω
Response time	Typical		4ms
	Maximum		7ms
Input type			Current sink
Input type in compliance with IEC 61131-2 standard			Type 3
Reverse polarity			Protected
Fuse type	Internal		None
	External		1 fast blow fuse of 0.5 A for 8-channel group
2-wire / 3-wire proximity sensor compatibility (IEC 60947-5-2 standard compliant)			2-wire (DC), and 3-wire (DC) PNP any type, page 87
Reliability	MTBF for continuous operation in hours at ambient temperature 30 °C (86 °F)		427 772
Dielectric strength	Primary/secondary		1500 V actual, 50 / 60 Hz for 1 min.
	Between input/output groups		500 VCC
Resistance of insulation			>10 M Ω (below 500 VDC)
Paralleling of inputs			No
Sensor voltage: monitoring threshold	OK		> 18 V
	Error		< 14 V
Sensor voltage: monitoring response time at 24 V (-15% ... +20%)	On appearance		8 ms < T < 30 ms
	On disappearance		1 ms < T < 3 ms
Power consumption 3.3 V	Typical		79 mA
	Maximum		111 mA
24 V pre-actuator consumption (excluding load current)	Typical		59 mA
	Maximum		67 mA
Power dissipation			3.7 W max.

NOTE: These characteristics are available also for the **BMX DDM 16022H** in the temperature range -25...60 °C (-13...140 °F). At +70 °C (158 °F), the maximum voltage value of input Sensor supply must not exceed 26.4 V.

▲ WARNING

LOSS OF INPUT FUNCTION

Do not operate the **BMX DDM 16022H** at 70 °C (158 °F) if the sensor power supply is greater than 29.0 V or less than 21.1 V. Overheating the module can cause the loss of the input function.

Failure to follow these instructions can result in death, serious injury, or equipment damage.

General Output Characteristics

The following table shows the general output characteristics of the BMX DDM 16022 and BMX DDM 16022H modules:

Output module type		24 VDC positive logic static outputs
Operating temperature	BMX DDM 16022	0...60 °C (32...140 °F)
	BMX DDM 16022H	-25...70 °C (-13...158 °F)
Temperature derating		Apply the temperature derating curve , page 34
Nominal values	Voltage	24 VDC
	Current	0.5 A
Threshold values	Voltage (including ripple)	19...30 V (34 V possible for 1 hour/day)
	Current/channel	0.625 A
	Current/module	5 A
Power of tungsten filament lamp	Maximum	6 W
Leakage current	At 0	< 0.5 mA
Voltage drop	At 1	< 1.2 V
Load impedance	Minimum	48 Ω
Response time⁽¹⁾		1.2 ms
Max. overload time before internal damage		15 ms
Reliability	MTBF for continuous operation in hours at	427 772

	ambient temperature 30 °C (86 °F)	
Frequency of switching to inductive load		0.5 / LI ² Hz
Paralleling of outputs		Yes (maximum of 2)
Compatibility with IEC 61131-2 DC direct inputs		Yes (type 3 and no type)
Built-in protection	Against over voltage	Yes, by Transil diode
	Against inversions	Yes, by inverted diode ⁽²⁾
	Against short-circuits and overloads	Yes, by current limiter and electric circuit-breaker $1.5 I_n < I_d < 2 I_n$
Fuse type	Internal	None
	External	1 fast blow fuse of 6.3 A for 8-channel group
Pre-actuator voltage: monitoring threshold	OK	> 18 V
	Error	< 14 V
Pre-actuator voltage: monitoring response time at 24 V (-15% ... +20%)	On appearance	8 ms < T < 30 ms
	On disappearance	1 ms < T < 3 ms
Power consumption 3.3 V	Typical	79 mA
	Maximum	111 mA
24 V pre-actuator consumption (excluding load current)	Typical	59 mA
	Maximum	67 mA
Power dissipation		3.7 W max.
Dielectric strength	Output / ground or output / internal logic	1500 V actual, 50 / 60 Hz for 1 min.
Resistance of insulation		>10 MΩ (below 500 VDC)
(1) All outputs are equipped with fast demagnetization circuits for electromagnets. Electromagnet discharge time < L/R.		
(2) Provide a 6.3 A fuse to the +24 V pre-actuator supply		

NOTE: The characteristics in this table also apply to the **BMX DDM 16022H** in the temperature range -25...60 °C (-13...140 °F).

At 70 °C (140 °F):

- The maximum voltage of the pre-actuator power supply must not exceed 26.4 V.
- The maximum output current must not exceed 0.55 A.

⚠ WARNING

LOSS OF OUTPUT FUNCTION

Do not operate the **BMX DDM 16022H** at 70 °C (158 °F) if the pre-actuator power supply is greater than 29.0 V or less than 21.1 V. Overheating the module can cause the loss of the output function.

Failure to follow these instructions can result in death, serious injury, or equipment damage.

Connecting the Module

At a Glance

The BMX DDM 16022 module is fitted with a removable 20-pin terminal block for the connection of eight input channels and eight output channels.

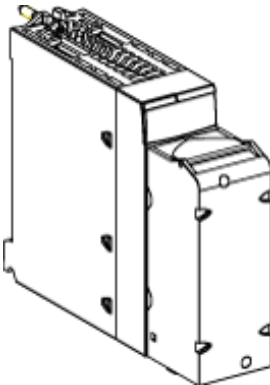

Input Circuit Diagram

The following diagram shows the circuit of a direct current input (positive logic).

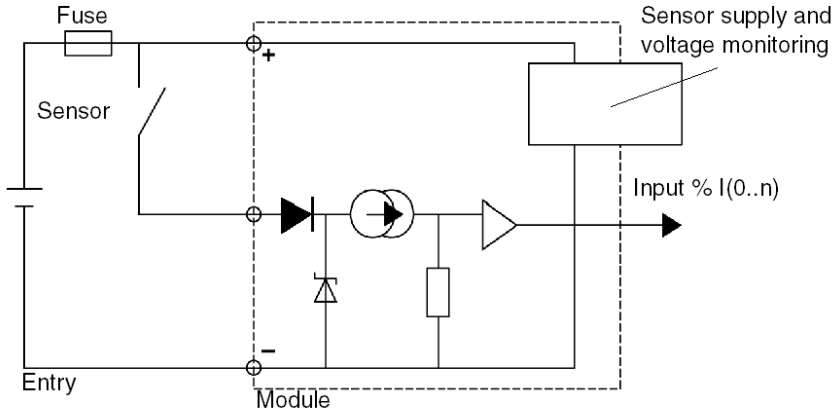

Output Circuit Diagram

The following diagram shows the circuit of a direct current output (positive logic).

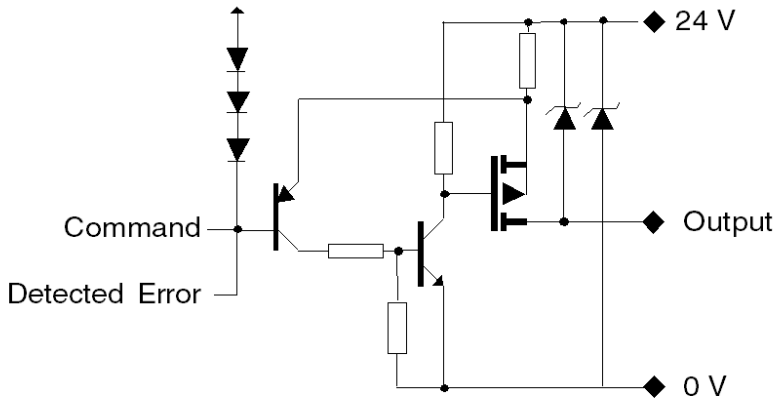

Module Connection

DANGER

HAZARD OF ELECTRICAL SHOCK, EXPLOSION OR ARC FLASH

Switch off the sensor and pre-actuator voltages before connecting or disconnecting the module.

Failure to follow these instructions will result in death or serious injury.

CAUTION

LOSS OF INPUT FUNCTION

Install the correct rating and type of fuse.

Failure to follow these instructions can result in injury or equipment damage.

The following diagram shows the connection of the module to the sensors and pre-actuators.

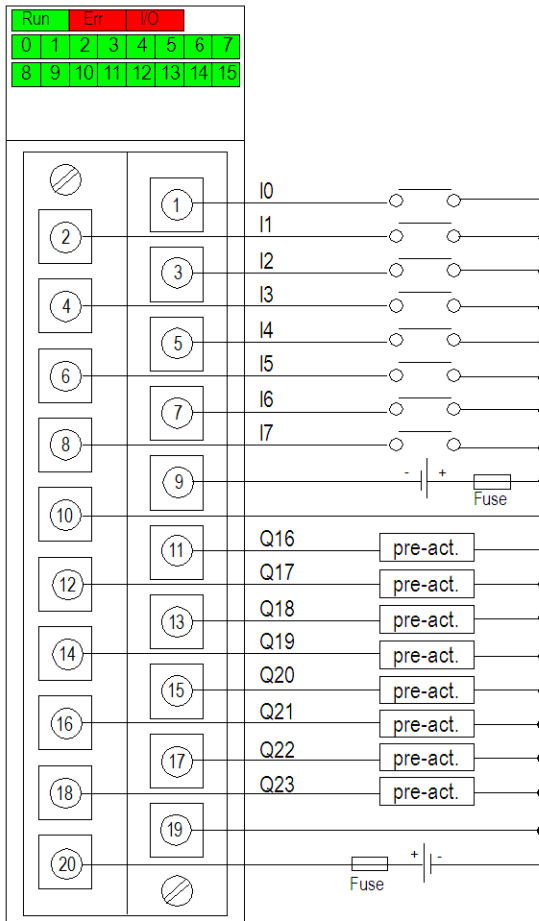

power supply: 24 VDC

input fuse: fast blow fuse of 0.5 A

output fuse: fast blow fuse of 6.3 A

pre-act: pre-actuator

Sensor Power Outage

After a power sensor outage, if the **Supply monitoring** check box is not selected in the module configuration screen then the digital input can stay active.

▲ WARNING

DIGITAL INPUT STATE INACTIVE AFTER A SENSOR POWER OUTAGE

Do not click to clear the **Supply monitoring** check box in the module configuration screen to guarantee the digital input state inactive after sensor power outage.

Failure to follow these instructions can result in death, serious injury, or equipment damage.

To access the **Supply monitoring** check box, refer to chapter *How to Modify the External Power Supply Error Monitoring Parameter*, page 351.

After the sensor power outage, the I/O (red) LED of the module switches on and the last recorded position of the sensor is displayed by the input channel status LED's.

▲ WARNING

CHANNEL LED INFORMATION NOT MATCHING SENSORS POSITION

After a sensor power outage:

- The I/O error LED is on
- Do not take into account the input LEDs information (they show the last recorded position of the sensors, not their real positions)
- Check the real positions on the sensors.

Failure to follow these instructions can result in death, serious injury, or equipment damage.

BMX DDM 16025 Mixed Relay Input/Output module

What's in This Chapter

Introduction	281
Characteristics.....	282
Connecting the Module	286

Subject of this Section

This section presents the BMX DDM 16025 module, its characteristics, and explains how it is connected to the sensors and pre-actuators.

Introduction

Function

The BMX DDM 16025 module is a 24 VDC discrete module connected via a 20-pin terminal block. It is a positive logic module: its 8 input channels receive current from the sensors (sink). The 8 isolated relay outputs operate either on direct current (24 VDC) or alternating current (24...240 VAC).

Ruggedized Version

The BMX DDM 16025H (hardened) equipment is the ruggedized version of the BMX DDM 16025 (standard) equipment. It can be used at extended temperatures and in harsh chemical environments.

For more information, refer to chapter *Installation in More Severe Environments* (see Modicon M580, M340, and X80 I/O Platforms, Standards and Certifications).

Illustration

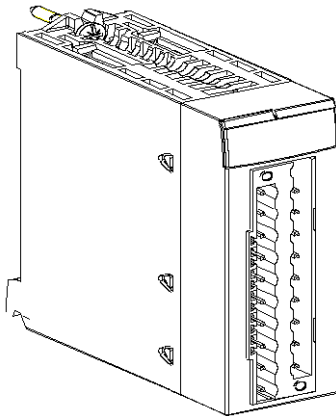

Characteristics

Altitude Operating Conditions

The characteristics in the tables below apply to the modules BMX DDM 16025 and BMX DDM 16025H for use at altitude up to 2000 m (6560 ft). When the modules operate above 2000 m (6560 ft), apply additional derating.

For detailed information, refer to chapter *Operating and Storage Conditions* (see Modicon M580, M340, and X80 I/O Platforms, Standards and Certifications).

General Input Characteristics

This table presents the general input characteristics for the BMX DDM 16025 and BMX DDM 16025H modules:

Input module type		Eight 24 VDC positive logic inputs	
Operating temperature	BMX DDM 16025	0...60 °C (32...140 °F)	
	BMX DDM 16025H	-25...70 °C (-13...158 °F)	
Nominal input values		Voltage	24 VDC
		Current	3.5 mA
Threshold input values	At 1	Voltage	≥ 11 V
		Current	≥ 2 mA for U ≥ 11 V

	At 0	Voltage	5 V
		Current	< 1.5 mA
	Sensor supply (including ripple)		19...30 V (possibly up to 34 V, limited to 1 hour/day)
Input impedance	At nominal U		6.8 kΩ
Response time	Typical		4 ms
	Maximum		7 ms
Input type			Current sink
Input type in compliance with IEC 61131-2 standard			Type 3
Reverse polarity			Protected
Fuse type	Internal		None
	External		1 fast blow fuse of 0.5 A for 8-channel group
2-wire / 3-wire proximity sensor compatibility (IEC 60947-5-2 standard compliant)			2-wire (DC), and 3-wire (DC) PNP any type, page 87
Reliability	MTBF for continuous operation in hours at ambient temperature 30 °C (86 °F)		835 303
Dielectric strength	Primary/secondary		1500 V actual, 50 / 60 Hz for 1 min.
	Between input/output groups		500 VDC
Resistance of insulation			>10 MΩ (below 500 VDC)
Paralleling of inputs			No
Sensor voltage: monitoring threshold	OK		> 18 V
	Error		< 14 V
Sensor voltage: monitoring response time at 24V (-15% ... +20%)	On appearance		8 ms < T < 30 ms
	On disappearance		1 ms < T < 3 ms
Power consumption 3.3 V	Typical		35 mA
	Maximum		50 mA
24 V pre-actuator consumption (excluding load current)	Typical		79 mA
	Maximum		111 mA
Power dissipation			3.1 W max.

NOTE: For the **BMX DDM 16025H**, at 70 °C (158 °F) the maximum pre-actuator power supply must not exceed 26.4 V.

▲ WARNING

LOSS OF INPUT FUNCTION

Do not operate the **BMX DDI 16025H** at 70 °C (158 °F) if the sensor power supply is greater than 29.0 V or less than 21.1 V. Overheating the module can cause the loss of the input function.

Failure to follow these instructions can result in death, serious injury, or equipment damage.

General Output Characteristics

The following table shows the general output characteristics of the BMX DDM 16025 and BMX DDM 16025H modules:

Output module type		Eight 24 VDC/24-240 VAC relay outputs
Operating temperature	BMX DDM 16025	0...60 °C (32...140 °F)
	BMX DDM 16025H	-25...70 °C (-13...158 °F)
Nominal values	Switching direct voltage	24 VDC resistive load
	Switching direct current	2 A resistive load
	Switching alternating voltage	220 VAC, Cos Φ = 1
	Switching alternating current	2 A, Cos Φ = 1
Minimum switching load	Voltage / Current	5 VDC / 1 mA.
Maximum switching load	Voltage	264 VAC / 125 VDC
On-line module change		Possibility
Response time	Activation	≤ 8 ms
	Deactivation	≤ 10 ms
Mechanical service life	Number of switching	20 million or more
Reliability	MTBF for continuous operation in hours at ambient temperature 30 °C (86 °F)	835 303
Max. switching frequency	Cycles per hour	3 600
Electrical service life		Switching voltage / current
		200 VAC / 1.5 A, 240 VAC / 1 A, Cos Φ = 0.7 ⁽¹⁾
		200 VAC / 0.4 A, 240 VAC / 0.3 A, Cos Φ = 0.7 ⁽²⁾
		200 VAC / 1 A, 240 VAC / 0.5 A, Cos Φ = 0.35 ⁽¹⁾

		200 VAC / 0.3 A, 240 VAC / 0.15 A, Cos Φ = 0.35 ⁽²⁾
		200 VAC / 1.5 A, 240 VAC / 1 A, Cos Φ = 0.7 ⁽¹⁾
		200 VAC / 0.4 A, 240 VAC / 0.3 A, Cos Φ = 0.7 ⁽²⁾
Noise immunity		In noise simulation, 1500 V actual, width 1s and 25 to 60 Hz
Fuse type	Internal	None
	External	1 fast blow fuse of 12 A for 8-channel group
Power consumption 3.3 V	Typical	79 mA
	Maximum	111 mA
24 V pre-actuator consumption	Typical	36 mA
	Maximum	58 mA
Power dissipation		3.1 W max.
Dielectric strength	Max. voltage	2830 VAC rms / cycles
Resistance of insulation		10 M Ω
(1) 1 x 10 ⁵ cycles		
(2) 3 x 10 ⁵ cycles		

NOTE: For the **BMX DDM 16025H**, at 70 °C (158 °F) the maximum pre-actuator power supply must not exceed 24 VA.

WARNING

LOSS OF OUTPUT FUNCTION

Do not operate the **BMX DDI 16025H** at 70°C (158°F) if the pre-actuator power supply is greater than 28.8 V or less than 19.2 V. Overheating the module can cause the loss of the output function.

Failure to follow these instructions can result in death, serious injury, or equipment damage.

Connecting the Module

At a Glance

The BMX DDM 16025 module is fitted with a removable 20-pin terminal block for the connection of eight input channels and eight isolated relay output channels.

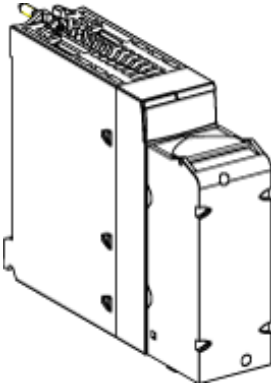

Input Circuit Diagram

The following diagram shows the circuit of a direct current input (positive logic).

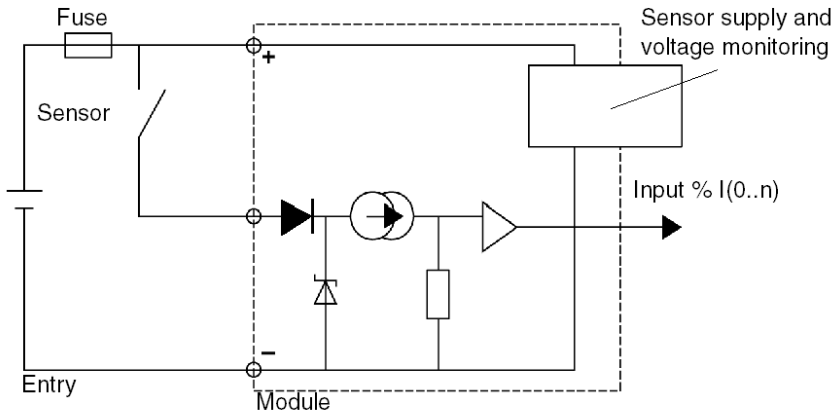

Output Circuit Diagram

The following diagram shows the circuit of relay outputs.

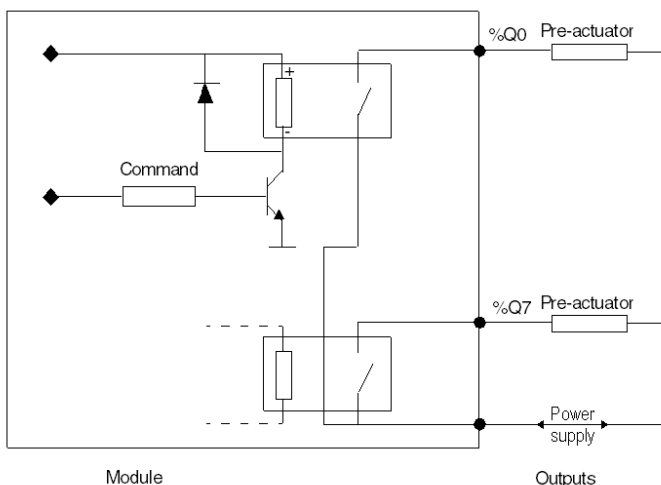

Module Connection

⚡ ⚠ DANGER

HAZARD OF ELECTRICAL SHOCK, EXPLOSION OR ARC FLASH

Switch off the sensor and pre-actuator voltages before connecting or disconnecting the module.

Failure to follow these instructions will result in death or serious injury.

⚠ CAUTION

LOSS OF INPUT FUNCTION

Install the correct rating and type of fuses.

Failure to follow these instructions can result in injury or equipment damage.

The diagram below shows the connection of the module to the sensors and pre-actuators.

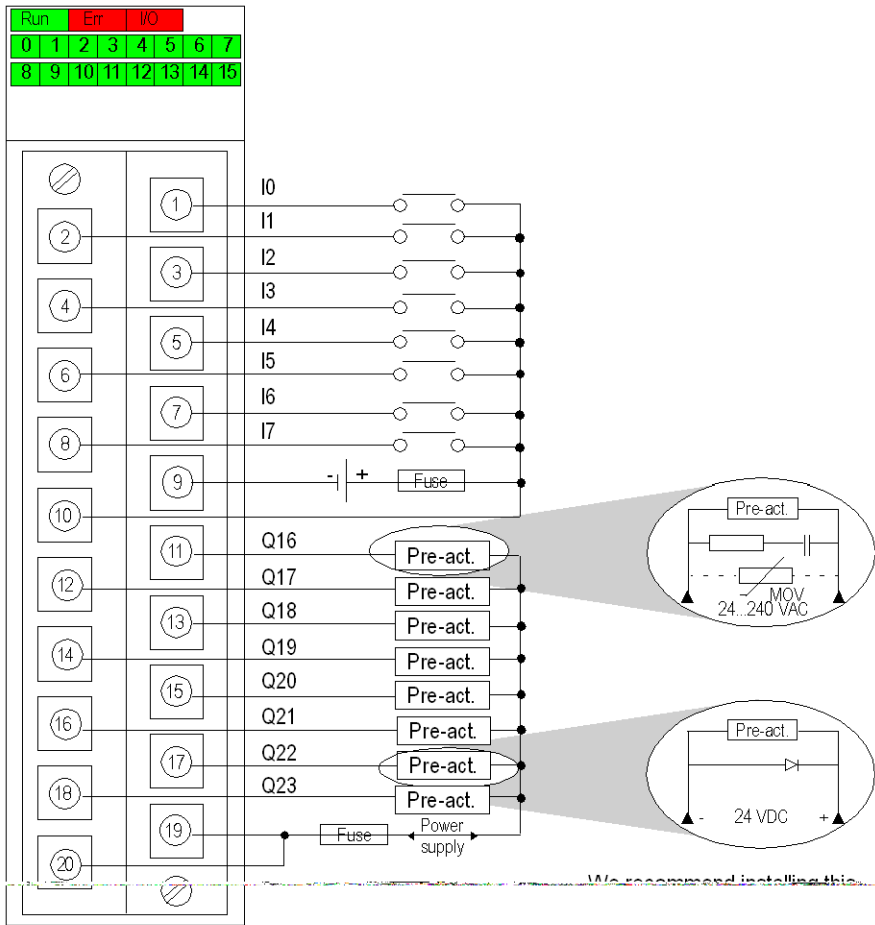

input power supply: 24 VDC

output power supply: 24 VDC or 24...240 VAC

input fuse: 1 fast blow fuse of 0.5 A

output fuse: 1 fast blow fuse of 12 A

pre-act: pre-actuator

Sensor Power Outage

After a power sensor outage, if the **Supply monitoring** check box is not selected in the module configuration screen then the digital input can stay active.

⚠ WARNING

DIGITAL INPUT STATE INACTIVE AFTER A SENSOR POWER OUTAGE

Do not click to clear the **Supply monitoring** check box in the module configuration screen to guarantee the digital input state inactive after sensor power outage.

Failure to follow these instructions can result in death, serious injury, or equipment damage.

To access the **Supply monitoring** check box, refer to chapter *How to Modify the External Power Supply Error Monitoring Parameter*, page 351.

After the sensor power outage, the I/O (red) LED of the module switches on and the last recorded position of the sensor is displayed by the input channel status LED's.

⚠ WARNING

CHANNEL LED INFORMATION NOT MATCHING SENSORS POSITION

After a sensor power outage:

- The I/O error LED is on
- Do not take into account the input LEDs information (they show the last recorded position of the sensors, not their real positions)
- Check the real positions on the sensors.

Failure to follow these instructions can result in death, serious injury, or equipment damage.

BMX DDM 3202 K Mixed Static Input/Output Module

What's in This Chapter

Introduction	290
Characteristics.....	291
Connecting the Module	294

Subject of this Section

This section presents the BMX DDM 3202 K module, its characteristics, and explains how it is connected to the sensors and pre-actuators.

Introduction

Function

The BMX DDM 3202 K module is a 24 VDC discrete module connected via a 40-pin connector. It is a positive logic module: its 16 input channels receive current from the sensors (sink) and its 16 output channels provide current to the pre-actuators (source).

Illustration

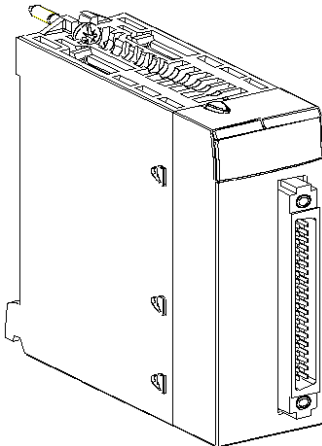

Characteristics

Altitude Operating Conditions

The characteristics in the tables below apply to the module BMX DDM 3202 K for use at altitude up to 2000 m (6560 ft). When the module operates above 2000 m (6560 ft), apply additional derating.

For detailed information, refer to chapter *Operating and Storage Conditions* (see Modicon M580, M340, and X80 I/O Platforms, Standards and Certifications).

General Input Characteristics

The following table shows the general input characteristics of the BMX DDM 3202 K module:

Input module type		24 VDC positive logic inputs		
Operating temperature		0...60 °C (32...140 °F)		
Nominal input values		Voltage	24 VDC	
		Current	2.5 mA	
Threshold input values	At 1	Voltage	≥ 11 V	
		Current	> 2 mA for U ≥ 11 V	
	At 0	Voltage	5 V	
		Current	< 0.5 mA	
	Sensor supply (including ripple)		19...30 V (possibly up to 34 V, limited to 1 hour/day)	
	Input impedance	At nominal U	9.6 kΩ	
Response time	Typical	4 ms		
	Maximum	7 ms		
Input type		Current sink		
Input type in compliance with IEC 61131-2 standard		Type 1		
Reverse polarity		Protected		
2-wire / 3-wire proximity sensor compatibility (IEC 60947-5-2 standard compliant)		2-wire (DC), and 3-wire (DC) PNP any type, page 87		
Fuse type	Internal	None		
	External	1 fast blow fuse of 0.5 A for 16-channel group		

Reliability	MTBF for continuous operation in hours at ambient temperature 30 °C (86 °F)	650 614
Dielectric strength	Primary/secondary	1500 V actual, 50 / 60 Hz for 1 min.
	Between input/output groups	500 VDC
Resistance of insulation		>10 MΩ (below 500 VDC)
Paralleling of inputs		No
Sensor voltage: monitoring threshold	OK	> 18 V
	Error	< 14 V
Sensor voltage: monitoring response time at 24 V (-15% ... +20%)	On appearance	8 ms < T < 30 ms
	On disappearance	1 ms < T < 3 ms
Power consumption 3.3 V	Typical	125 mA
	Maximum	166 mA
24 V pre-actuator consumption (excluding load current)	Typical	69 mA
	Maximum	104 mA
Power dissipation		4 W max.

General Output Characteristics

The following table shows the general output characteristics of the BMX DDM 3202 K module:

Output module type	24 VDC positive logic static outputs	
Operating temperature	0...60 °C (32...140 °F)	
Temperature derating	Apply the temperature derating curve , page 34	
Nominal values	Voltage	24 VDC
	Current	0.1 A
Threshold values	Voltage (including ripple)	19...30 V (34 V possible for 1 hour/day)
	Current/channel	0.125 A
	Current/module	3.2 A
Power of tungsten filament lamp	Maximum	1.2 W
Leakage current	at 0	100 µA for U = 30 V
Voltage drop	at 1	< 1.5 V for I = 0.1 A

Load impedance	Minimum	220 Ω
Response time⁽¹⁾		1.2 ms
Max. overload time before internal damage		15 ms
Reliability	MTBF for continuous operation in hours at ambient temperature 30 °C (86 °F)	650 614
Frequency of switching to inductive load		0.5 / LI ² Hz
Paralleling of outputs		Yes (maximum of 3)
Compatibility with IEC 61131-2 DC direct inputs		Yes (type 3 and no type)
Built-in protection	Against over voltage	Yes, by Transil diode
	Against inversions	Yes, by inverted diode ⁽²⁾
	Against short-circuits and overloads	Yes, by current limiter and electric circuit-breaker 0.125 A < I _d < 0.185 A
Fuse type	Internal	None
	External	1 fast blow fuse of 2 A for 16-channel group
Pre-actuator voltage: monitoring threshold	OK	> 18 V
	Error	< 14 V
Pre-actuator voltage: monitoring response time at 24 V (-15% ... +20%)	On appearance	8 ms < T < 30 ms
	On disappearance	1 ms < T < 3 ms
Power consumption 3.3 V	Typical	125 mA
	Maximum	166 mA
24 V pre-actuator consumption (excluding load current)	Typical	69 mA
	Maximum	104 mA
Power dissipation		4 W max.
Dielectric strength	Output / ground or output / internal logic	1500 V actual, 50 / 60 Hz for 1 min.
Resistance of insulation		>10 MΩ (below 500 VDC)
(1) All outputs are equipped with fast demagnetization circuits for electromagnet. Electromagnet discharge time < L/R.		
(2) Provide a 2 A fuse to the +24 V pre-actuator supply		

Connecting the Module

At a Glance

The BMX DDM 3202 K module is fitted with a 40-pin connector for the connection of sixteen input channels and sixteen output channels.

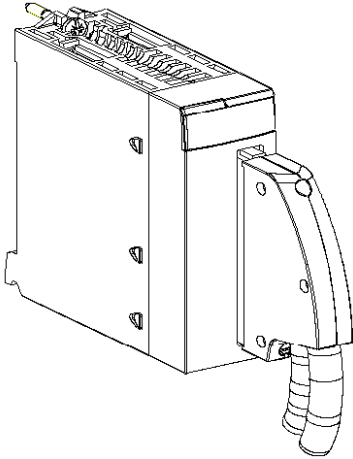

Input Circuit Diagram

The following diagram shows the circuit of a direct current input (positive logic).

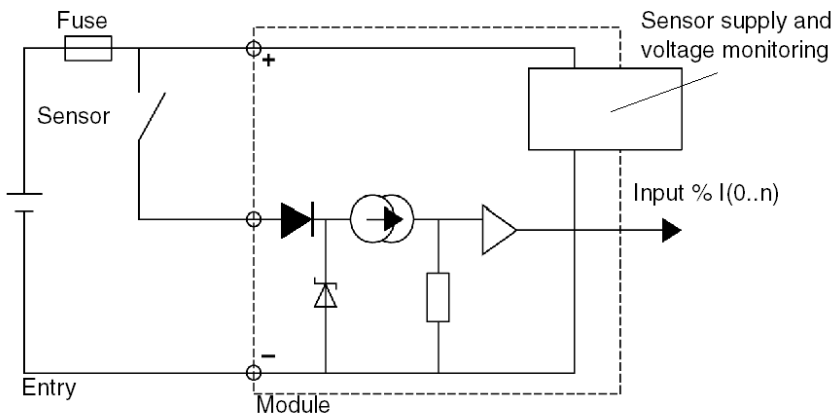

Output Circuit Diagram

The following diagram shows the circuit of a direct current output (positive logic).

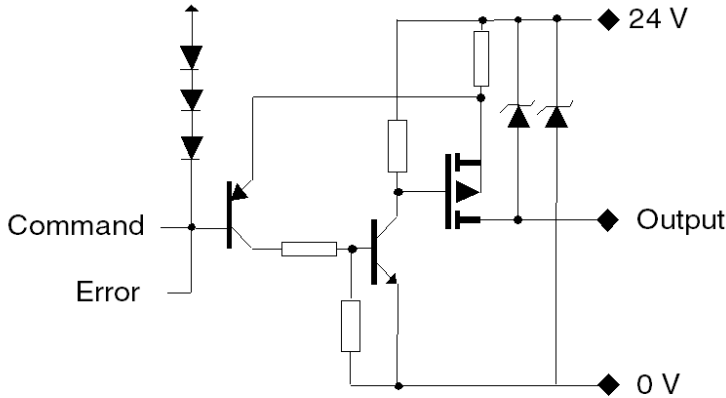

Module Connection

⚡ ⚠ DANGER

HAZARD OF ELECTRICAL SHOCK, EXPLOSION OR ARC FLASH

Switch off the sensor and pre-actuator voltages before connecting or disconnecting the module.

Failure to follow these instructions will result in death or serious injury.

⚠ CAUTION

LOSS OF INPUT FUNCTION

Install the correct rating and type of fuse.

Failure to follow these instructions can result in injury or equipment damage.

The following diagram shows the connection of the module to the sensors and pre-actuators.

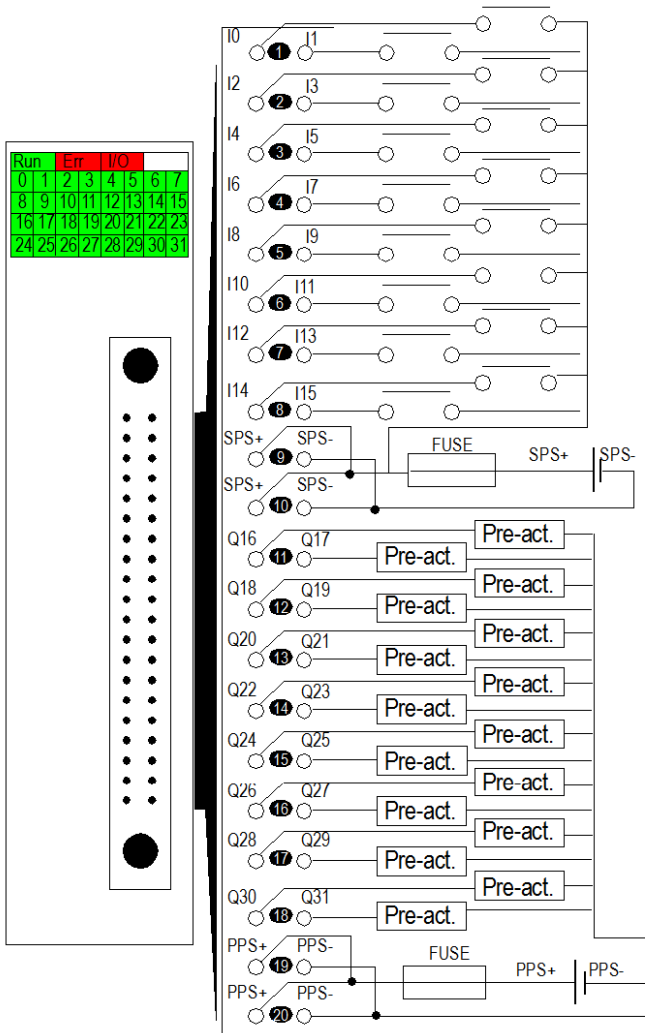

power supply: 24 VDC

input fuse: fast blow fuse of 0.5 A

output fuse: fast blow fuse of 2 A

pre-act: pre-actuator

SPS: sensor power supply

PPS: pre-actuator power supply

Sensor Power Outage

After a power sensor outage, if the **Supply monitoring** check box is not selected in the module configuration screen then the digital input can stay active.

⚠ WARNING

DIGITAL INPUT STATE INACTIVE AFTER A SENSOR POWER OUTAGE

Do not click to clear the **Supply monitoring** check box in the module configuration screen to guarantee the digital input state inactive after sensor power outage.

Failure to follow these instructions can result in death, serious injury, or equipment damage.

To access the **Supply monitoring** check box, refer to chapter *How to Modify the External Power Supply Error Monitoring Parameter*, page 351.

After the sensor power outage, the I/O (red) LED of the module switches on and the last recorded position of the sensor is displayed by the input channel status LED's.

⚠ WARNING

CHANNEL LED INFORMATION NOT MATCHING SENSORS POSITION

After a sensor power outage:

- The I/O error LED is on
- Do not take into account the input LEDs information (they show the last recorded position of the sensors, not their real positions)
- Check the real positions on the sensors.

Failure to follow these instructions can result in death, serious injury, or equipment damage.

TELEFAST 2 Connection Interface Links for the Discrete I/O Modules

What's in This Chapter

Introduction to the TELEFAST 2 Connection Interfaces for Discrete I/O	298
Connection Principles for the TELEFAST 2 Interfaces for Discrete I/O	307
TELEFAST 2 ABE-7H08R10/08R11 and ABE-7H16R10/16R11 Connection Bases	313
TELEFAST 2 ABE-7H12R10/12R11 Connection Bases	314
TELEFAST 2 ABE-7H08R21 and ABE-7H16R20/16R21/16R23 Connection Bases	316
TELEFAST 2 ABE-7H12R20/12R21 Connection Bases	318
TELEFAST 2 ABE-7H08S21/16S21 Connection Bases	319
TELEFAST 2 ABE-7H12S21 Connection Base.....	321
TELEFAST 2 ABE-7H16R30/16R31 Connection Bases	323
TELEFAST 2 ABE-7H12R50 Connection Base	325
TELEFAST 2 ABE-7H16R50 Connection Base	327
TELEFAST 2 ABE-7H16F43 Connection Base	329
TELEFAST 2 ABE-7H16S43 Connection Base.....	330
TELEFAST 2 Connection Base Accessories	332

Aim of this Chapter

This chapter describes the TELEFAST 2 interface links for the discrete input/output modules.

Introduction to the TELEFAST 2 Connection Interfaces for Discrete I/O

Aim of this section

This section describes the range of **TELEFAST 2** products which allow the discrete input and output modules to be connected quickly to the operating pieces.

General Overview of TELEFAST 2 Connection Interfaces for Discrete I/O Modules

At a Glance

The TELEFAST 2 system is a group of products which enableS discrete input and output modules to be quickly connected to operational components. It replaces 20-pin terminal blocks, thus doing away with single wire connections.

The TELEFAST 2 system, which consists of connection bases for interfaces and connection cables, can only be connected to modules which are fitted with 40-pin connectors.

Several base types can be identified:

- connection interface bases for 8/12/16-channel discrete inputs/outputs
- bases for connection and adaptation interfaces for inputs with 16 isolated channels
- bases for connection and adaptation interfaces for static outputs with 8 and 16 channels
- bases for connection and adaptation interfaces relating to relay outputs with 8 and 16 channels
- bases for adapter splitting 16 channels into 2 x 8 channels
- bases for connection and adaptation interfaces relating to outputs, with or without removable electromechanical or static relays, with 16 channels
- input bases for 12.5-mm wide static relays

TELEFAST 2 Connection Bases Catalog

At a Glance

The catalog of TELEFAST 2 bases for discrete input/output modules is shown here.

Catalog

The table below shows the catalog of connection interface bases for 8/12/16-channel discrete I/Os.

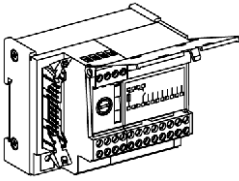
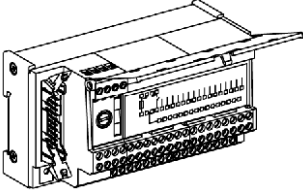
Reference ABE-7H**	08R10	08S21	12R50	12R10	16R10	12S21	16S43 (1)
	08R11		16R50	12R20	16R11	16S21	16F43 (2)
	08R21			12R21	16R20		
					16R21	16R23	
					16R30		
					16R31		
Base types	Connection interface bases for 8/12/16-channel discrete I/Os.						
Sub groups	8-channel bases		Compact 12 and 16-channel bases	12 and 16-channel bases			
Illustration	TELEFAST 2 base 			TELEFAST 2 base 			
Description	-	with 1 isolator/channel	-	-	-	with 1 isolator/channel	with 1 fuse + 1 isolator/channel
(1) for inputs							
(2) for outputs							

Illustration

The principle for identifying the connection interface bases for 8/12/16-channel discrete I/Os is as follows.

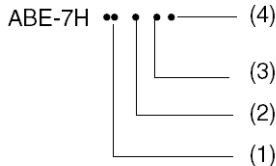

Description

The table below describes the different elements which make it possible to identify the connection interface bases for 8/12/16-channel discrete I/Os.

Number	Description
(1)	08 = 8-channel base 12 = 12-channel base 16 = 16-channel base
(2)	Primary function: <ul style="list-style-type: none">• R = simple connection• S = isolator/channel• F = fuse/channel
(3)	1 = with 1 screw terminal per channel on 1 level 2 = with 2 screw terminals per channel on 2 levels 3 = with 3 screw terminals per channel on 3 levels 4 = with 2 screw terminals per channel on 1 level 5 = with 1 screw terminal per channel on 2 levels
(4)	0 or even number = without LED display per channel odd number = with LED display per channel

Catalog

The table below shows the catalog of bases for connection and adaptation interfaces for inputs with 16 isolated channels.

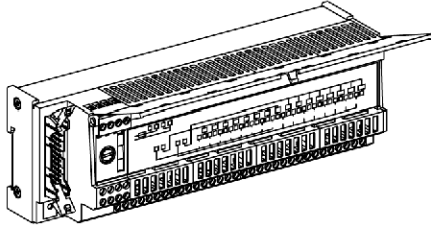
ABE-7S** reference	16E2B1	16E2E1	16E2E0	16E2F0	16E2M0
Base types	Bases for connection and adaptation interfaces for inputs with 16 isolated channels.				
Illustration	TELEFAST 2 base 				
Description	16 x 24 VDC inputs	16 x 48 VDC inputs	16 x 48 VAC inputs	16 x 110...120 VAC inputs	16 x 220...240 VAC inputs

The table below shows the catalog of bases for connection and adaptation interfaces for static outputs with 8 and 16 channels.

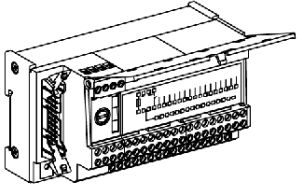
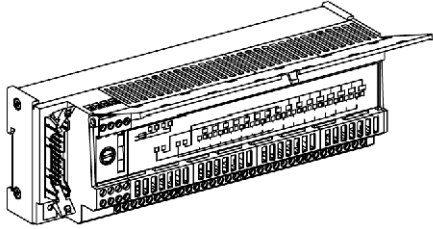
ABE-7S** reference	08S2B0	08S2B1	16S2B0	16S2B2
Base types	Bases for connection and adaptation interfaces for static outputs with 8 and 16 channels.			
Sub groups	8-channel bases		16-channel bases	
Illustration	TELEFAST 2 base 	TELEFAST 2 base 		
Description	8 static 24 VDC / 0.5A outputs, with error detection transfer to PLC.	8 static 24 VDC / 2A outputs, with error detection transfer to PLC.	16 static 24 VDC / 0.5A outputs, with error detection transfer to PLC.	16 static 24 VDC / 0.5A outputs, without error detection transfer to PLC.

The table below shows the catalog of bases for connection and adaptation interfaces for relay outputs with 8 and 16 channels.

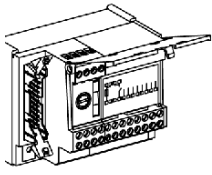
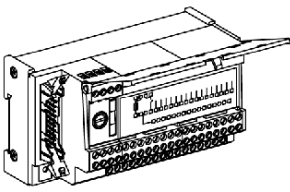
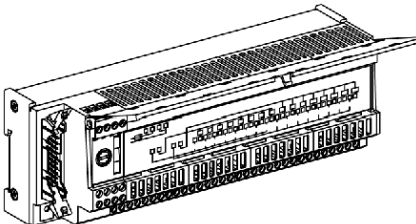
ABE-7R** reference	08S111	08S210	16S111	16S210	16S212
Base types	Bases for connection and adaptation interfaces for relay outputs with 8 and 16 channels.				
Sub groups	8-channel bases		16-channel bases		
Illustration	TELEFAST 2 base 	TELEFAST 2 base 	TELEFAST 2 base 		
Description	8 relay outputs, 1 F with + or alternating polarity distribution.	8 relay outputs, 1 F, potential free contact.	16 relay outputs, 1 F, 2 x 8 shared + or alternating.	16 relay outputs, 1 F, potential free contact.	16 relay outputs, 1 F with distribution of the 2 polarities by 8-channel group.

The table below displays the catalog entry showing the connection base for the adapter splitting 16 channels into 2 x 8 channels.

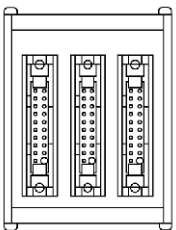
ABE-7A** reference	CC02
Base types	Bases for adapter splitting 16 channels into 2 x 8 channels.
Illustration	TELEFAST 2 base 
Description	Allows splitting of: <ul style="list-style-type: none"> • 16 channels into two x 8 channels • 12 channels into 8 channels + 4 channels

The table below shows the catalog of output adaptation interface bases with or without removable electromechanical or static relays with 16 channels.

ABE-7** reference	R16T210	P16T210	P16T214	R16T212	P16T212	P16T215	P16T318
Base types	Output adaptation interface bases with or without removable electromechanical or static relays with 16 channels						
Sub groups	Output bases, 1 F, potential free contact.			Output bases, 1 F, distribution of the 2 polarities by 8-channel group.		Output base, 1 F, distribution of the 2 polarities by 4-channel group.	
Illustration	<p>TELEFAST 2 base</p>						
Description	with 10-mm wide electro-mechanical relay	10-mm wide relay not provided	10-mm wide relay not provided, 1 fuse/channel	with 10-mm wide electro-mechanical relay	10-mm wide relay not provided	10-mm wide relay not provided, 1 fuse/channel	12.5-mm wide relay, not provided, 1 fuse + 1 isolator/channel

The table below shows the catalog of output adaptation interface bases with or without removable electromechanical or static relays with 16 channels (continued).

ABE-7** reference	R16T230	R16T330	P16T330	P16T334	R16T231	R16T332	P16T332	R16T370
Base types	Output adaptation interface bases with or without removable electromechanical or static relay with 16 channels (continued).							
Sub groups	Output bases, 1 OF, potential free contact.				Output bases, 1 OF, shared by 8-channel group.	Output bases, 1 OF, distribution of the 2 polarities by 8-channel group.		Output bases, 2 OF, potential free contact.
Illustration	<p>TELEFAST 2 base</p>							
Description	with 10-mm wide electro-mechanical relay	with 12.5-mm wide electro-mechanical relay	12.5-mm wide relay, not provided	12.5-mm wide relay, not provided, 1 fuse/channel	with 10-mm wide electro-mechanical relay	with 12.5-mm wide electro-mechanical relay	12.5-mm wide relay, not provided	with 12.5-mm wide electro-mechanical relay

The table below shows the catalog of input bases for 12.5-mm wide static relays.

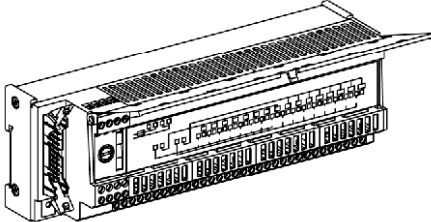
ABE-7P** reference	16F310	16F312
Base types	Input bases for 12.5-mm wide static relays	
Illustration	TELEFAST 2 base 	
Description	potential free	distribution of the 2 polarities by 8-channel group

Combination of Discrete I/O Modules and TELEFAST 2 Connection Bases

Compatibility Table

The following table summarizes compatibility between Discrete I/O modules and TELEFAST 2 connection bases.

	BMX DDI 3202 K	BMX DDI 6402 K	BMX DDO 3202 K	BMX DDO 6402 K	BMX DDM 3202 K
	1 connector	2 connectors	1 connector	2 connectors	1 connector
Connection bases					
8 channels					
ABE-7H08R**	+ (1)	+ (1)	+ (1)	+ (1)	+ (1)
ABE-7H08S21	+ (1)	+ (1)	+ (1)	+ (1)	+ (1)
12 channels					
ABE-7H12R**	-	-	-	-	-
ABE-7H12S21	-	-	-	-	-
16 channels					
ABE-7H16R**	+	+	+	+	+
ABE-7H16S21	+	+	+	+	+
ABE-7H16R23	+	+	-	-	+
ABE-7H16F43	-	-	+	+	-
ABE-7H16S43	-	-	-	-	-

	BMX DDI 3202 K	BMX DDI 6402 K	BMX DDO 3202 K	BMX DDO 6402 K	BMX DDM 3202 K
	1 connector	2 connectors	1 connector	2 connectors	1 connector
Input adapter connection bases					
16 channels					
ABE-7S16E2••	+	+	-	-	+
ABE-7P16F3••	+	+	-	-	+
Output adapter connection bases					
8 channels					
ABE-7S08S2••	-	-	+ (1)	+ (1)	+ (1)
ABE-7R08S•••	-	-	+ (1)	+ (1)	+ (1)
16 channels					
ABE-7R16S•••	-	-	+	+	+
ABE-7R16T•••	-	-	+	+	+
ABE-7P16T•••	-	-	+	+	+
(1) With 16 to 2 x 8 channel adapter ABBE-7ACC02 + Compatible - Not compatible					

Connection Principles for the TELEFAST 2 Interfaces for Discrete I/O

Aim of this section

This section describes the connection principles for the **TELEFAST 2** products for discrete input/output modules.

Connecting a Discrete Input/Output Module to a TELEFAST 2 Base Interface

At a Glance

A discrete input/output module with a 40-pin connector can be connected to the TELEFAST 2 connection base with a connection cable, page 82.

Illustration

The following diagram shows the connection of a discrete input/output module with a 40-pin connector to a **TELEFAST 2** connection base.

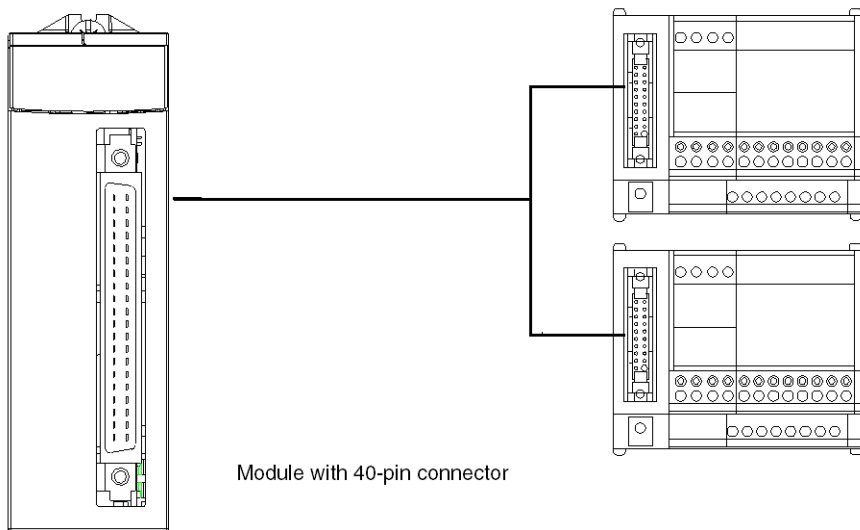

Illustration

The following diagram shows an example specific to the connection of 16 channels in 2 x 8-channel groups via the **ABE-7ACC02** adapter base.

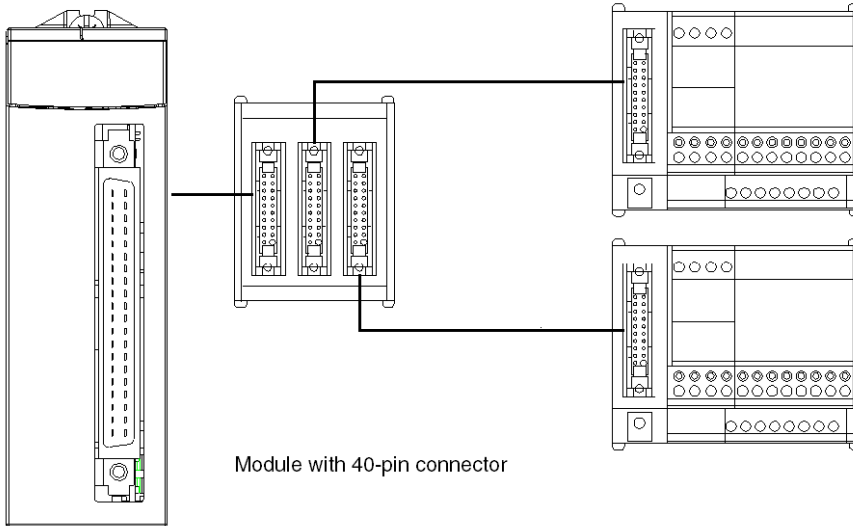

Dimensions and Mounting of the TELEFAST 2 Connection Bases

At a Glance

Here is an overview of the dimensions of different TELEFAST 2 connection products and their mounting methods.

Illustration

The illustration below shows the dimensions (in mm) of the products: ABE-7H•R1•, ABE-7H•R5•, ABE-7H•R2•, ABE-7H•S21, ABE-7H16R3•, ABE-7S08S2B0, ABE-7R•S1••, ABE-7R08S210.

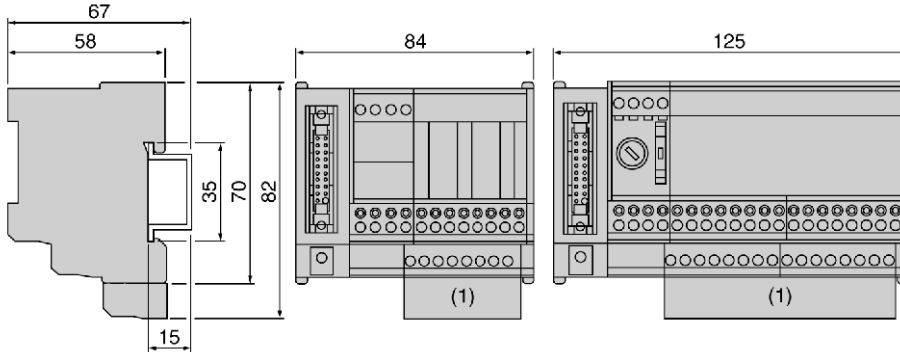

(1) Dimension with additional shunt terminal block ABE-7BV20 or ABE-7BV10.

The illustration below shows the dimensions (in mm) of the products: ABE-7H16S43, ABE-7S16E2••, ABE-7S08S2B1, ABE-7S16S2B•, ABE-7H16F43•, ABE-7R16S21.

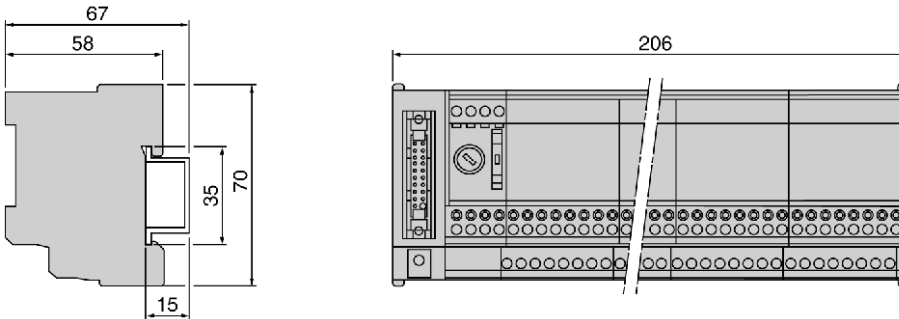

The illustration below shows the dimensions (in mm) of the product ABE-7ACC02.

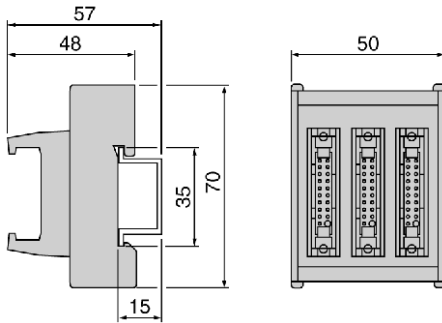

The illustration below shows the dimensions (in mm) of the products: ABE-7R16T2•• and ABE-7P16T2••.

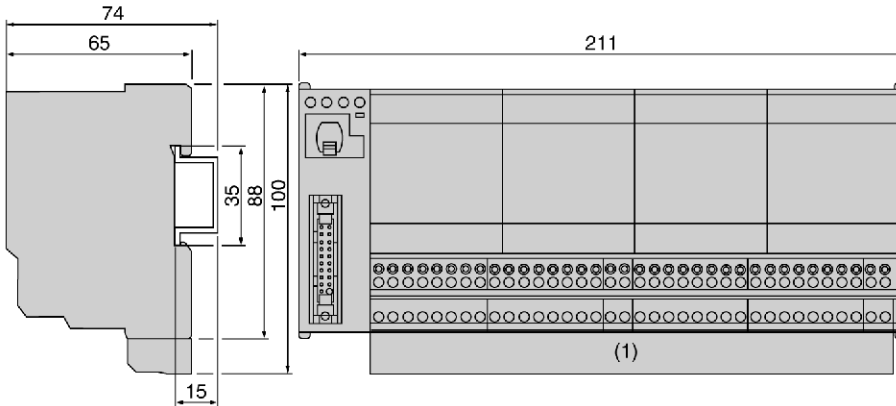

Reference measuring 211 x 88 mm (product shown has removable relays and non-mounted screws).

(1) Dimension with additional shunt terminal block ABE-7BV20 or ABE-7BV10.

The illustration below shows the dimensions (in mm) of the products: ABE-7R16T3•• and ABE-7P16T3••.

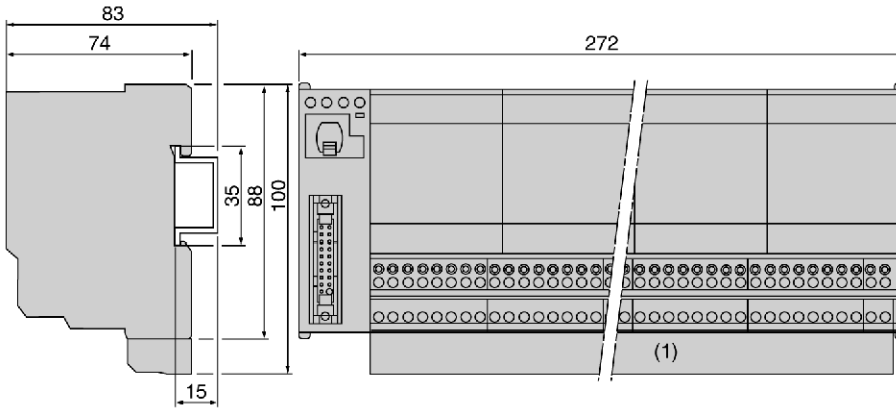

Reference measuring 272 x 88 mm (product shown has removable relays and non-mounted screws).

(1) Dimension with additional shunt terminal block ABE-7BV20 or ABE-7BV10.

Mounting

The TELEFAST 2 bases are mounted on 35-mm wide DIN mounting rails.

▲ WARNING

UNEXPECTED EQUIPMENT OPERATION

Install the input adaptation bases ABE-7S16E2E1 and static output adaptation bases ABE-7S••S2B• lengthways and horizontally to prevent the device from overheating and unexpected operation.

Failure to follow these instructions can result in death, serious injury, or equipment damage.

TELEFAST 2 ABE-7H08R10/08R11 and ABE-7H16R10/16R11 Connection Bases

Aim of this section

This section introduces the **TELEFAST 2 ABE-7H08R10/08R11** and **ABE-7H16R10/16R11** connection bases.

Sensor and Pre-actuator Connections on the ABE-7H08R10/R11 and ABE-7H16R10/R11 Bases

At a Glance

This is an overview of the sensor and pre-actuator connections on TELEFAST 2 bases.

NOTE: The bases are manufactured with a general-purpose, quick-blow fuse rated 6.3 A. To guarantee optimum protection, this fuse should be rated according to the application (connection to input or output functions) and the maximum current allowable in the base.

Type and rating of fuse to be fitted to the base:

- input functions: 0.5 A quick-blow
- output functions:
 - 2 A quick-blow on the ABE-7H16R•• base
 - 6.3 A quick-blow on the ABE-7H08R•• base

Illustration

Description of the connection terminal blocks.

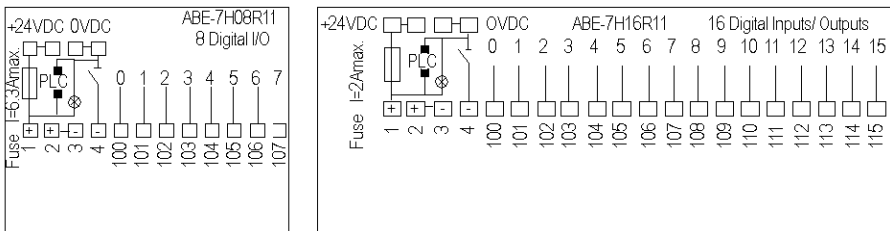

Illustration

Connections for input and output functions.

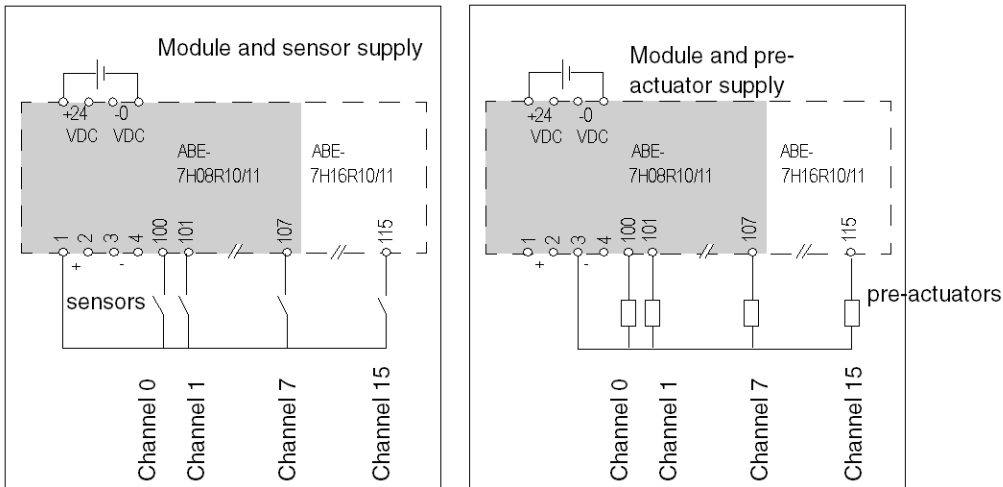

Connecting the common for sensors:

- onto terminals 1 or 2: sensors to the '+' of the supply (positive logic inputs)

Connecting the common for pre-actuators:

- onto terminals 3 or 4: pre-actuators to the '-' of the supply (positive logic outputs)

TELEFAST 2 ABE-7H12R10/12R11 Connection Bases

Aim of this section

This section introduces the **TELEFAST 2 ABE-7H12R10/12R11** connection bases.

Sensor and Pre-actuator Connections on the ABE-7H12R10/R11 Bases

At a Glance

This is an overview of the sensor and pre-actuator connections on TELEFAST 2 bases.

NOTE: The bases are manufactured with a general-purpose, quick-blow fuse rated 6.3 A. To guarantee optimum protection, this fuse should be rated according to the application (connection to input or output functions) and the maximum current allowable in the base.

Type and rating of fuse to be fitted to the base:

- input functions: 0.5 A quick-blow
- output functions: 6.3 A quick-blow on the ABE-7H12R ••base

Illustration

Description of the connection terminal blocks.

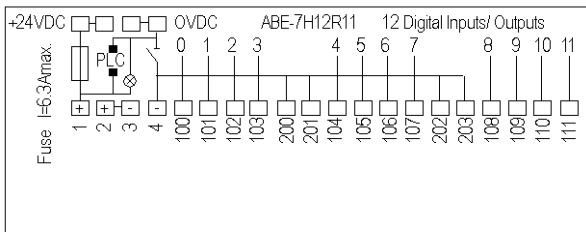

Illustration

Connections for input and output functions.

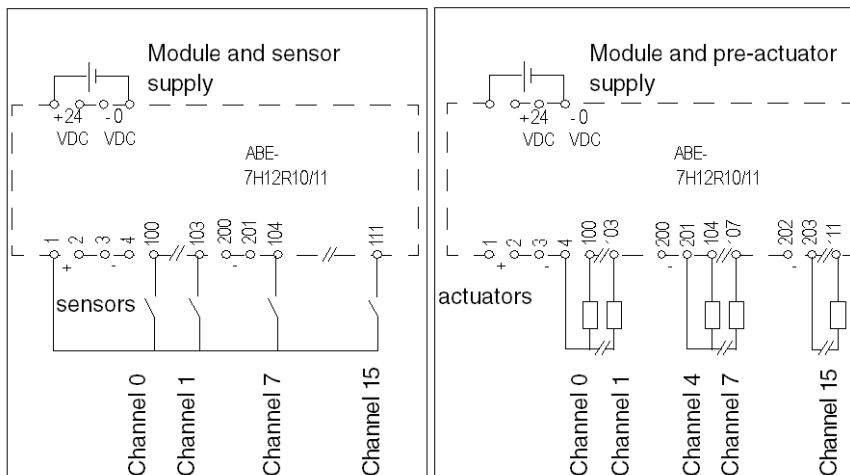

Connecting the common for sensors:

- onto terminals 1 or 2: sensors to the '+' of the supply (positive logic inputs)

Connecting the common for pre-actuators:

- several terminals linked to the '-' polarity (3, 4, 200, 201, 202, and 203) allowing sharing in groups of 4 or 2 channels (positive logic outputs)

TELEFAST 2 ABE-7H08R21 and ABE-7H16R20/16R21/ 16R23 Connection Bases

Aim of this section

This section introduces the **TELEFAST 2 ABE-7H08R21** and **ABE-7H16R20/16R21/16R23** connection bases.

Sensor and Pre-actuator Connections on the ABE-7H08R21 and ABE-7H16R20/R21/R23 Bases for Type 2 Inputs

At a Glance

This is an overview of the sensor and pre-actuator connections on TELEFAST 2 bases.

NOTE: The bases are manufactured with a general-purpose, quick-blow fuse rated 2 A. To guarantee optimum protection, this fuse should be rated according to the application (connection to input or output functions) and the maximum current allowable in the base.

Type and rating of fuse to be fitted to the base:

- input functions: 0.5 A quick-blow
- output functions:
 - 2 A quick-blow on the ABE-7H16R•• base
 - 6.3 A quick-blow on the ABE-7H08R•• base

Illustration

Description of the connection terminal blocks.

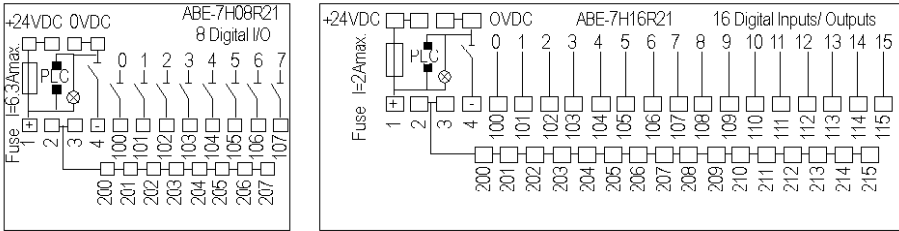

Illustration

Connections for input and output functions.

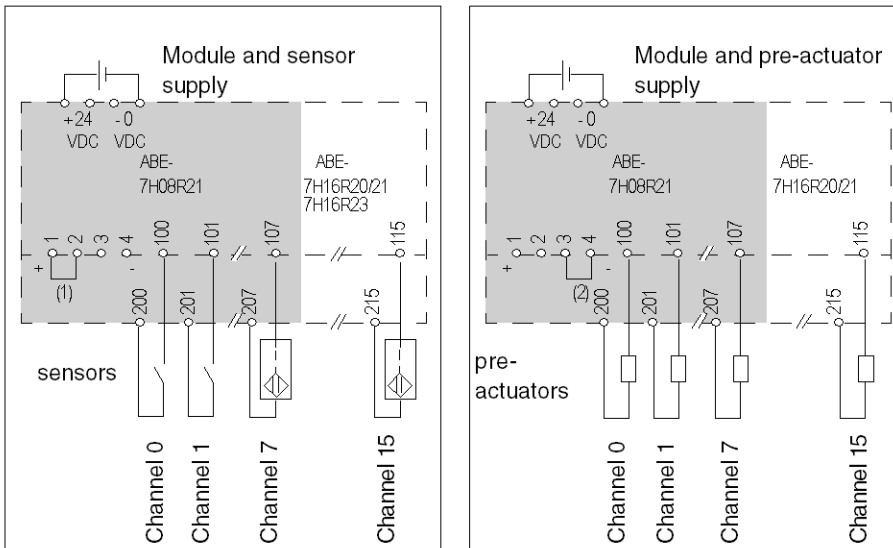

Connecting the common for sensors:

- In order to create the shared sensor supply, position the jumper (1) on terminals 1 and 2: terminals 200 to 215 will be on the '+' of the supply (positive logic inputs).

Connecting the common for pre-actuators:

- In order to create the shared supply for the pre-actuators, position the jumper (2) on terminals 3 and 4: terminals 200 to 215 will be on the '-' of the supply (positive logic outputs).

TELEFAST 2 ABE-7H12R20/12R21 Connection Bases

Aim of this section

This section introduces the **TELEFAST 2 ABE-7H12R20/12R21** connection bases.

Sensor and Pre-actuator Connections on the ABE-7H12R20/12R21 Bases

At a Glance

This is an overview of the sensor and pre-actuator connections on TELEFAST 2 bases.

NOTE: The bases are manufactured with a general-purpose, quick-blow fuse rated 6.3 A. To guarantee optimum protection, this fuse should be rated according to the application (connection to input or output functions) and the maximum current allowable in the base.

Type and rating of fuse to be fitted to the base:

- input functions: 0.5 A quick-blow
- output functions: 6.3 A quick-blow on the ABE-7H12R•• base

Illustration

Description of the connection terminal blocks.

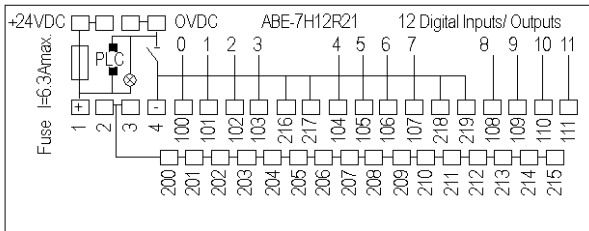

Illustration

Connections for input and output functions.

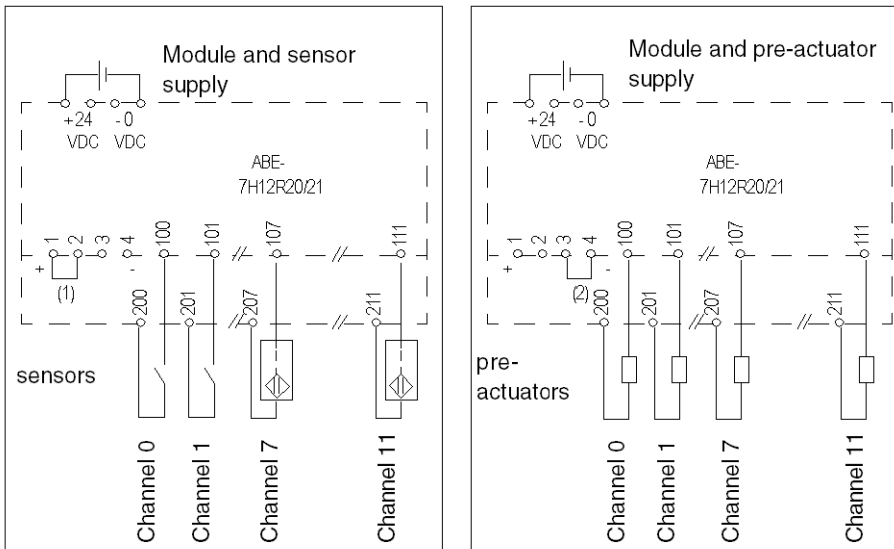

Connecting the common for sensors:

- In order to create the shared sensor supply, position the jumper (1) on terminals 1 and 2: terminals 200 to 215 will be on the '+' of the supply (positive logic inputs).

Terminals 216, 217, 218 and 219 are linked to the '-' polarity.

Connecting the common for pre-actuators:

- In order to create the shared supply for the pre-actuators, position the jumper (2) on terminals 3 and 4: terminals 200 to 215 will be on the '-' of the supply (positive logic outputs).

Terminals 216, 217, 218 and 219 are linked to the '-' polarity

TELEFAST 2 ABE-7H08S21/16S21 Connection Bases

Aim of this section

This section introduces the connection bases **TELEFAST 2 ABE-7H08S21/16S21**.

Sensor and Pre-actuator Connections on ABE-7H08S21/16S21 Bases with One Isolator per Channel

At a Glance

This is an overview of the sensor and pre-actuator connections on TELEFAST 2 bases.

NOTE: The bases are manufactured with a general-purpose, quick-blow fuse rated 2 A. To guarantee optimum protection, this fuse should be rated according to the application (connection to input or output functions) and the maximum current allowable in the base.

Type and rating of fuse to be fitted to the base:

- input functions: 0.5 A quick-blow
- output functions:
 - 2 A quick-blow on the ABE-7H16S21 base
 - 6.3 A quick blow on the ABE-7H08S21 base

Illustration

Description of the connection terminal blocks.

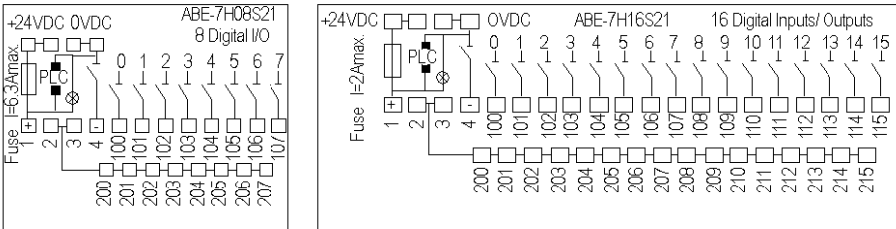

Illustration

Connections for input and output functions.

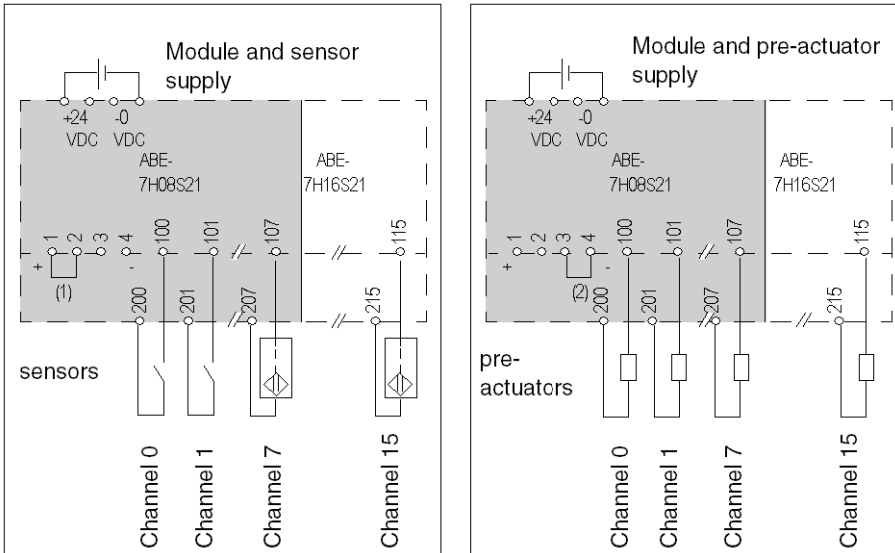

Connecting the common for sensors:

- In order to create the shared sensor supply, position the jumper (1) on terminals 1 and 2: terminals 200 to 215 will be on the '+' of the supply (positive logic inputs).

Connecting the common for actuators:

- In order to create the shared supply for the actuators, position the jumper (2) on terminals 3 and 4: terminals 200 to 215 will be on the '-' of the supply (positive logic outputs).

TELEFAST 2 ABE-7H12S21 Connection Base

Aim of this section

This section describes the connection base **TELEFAST 2 ABE-7H12S21**.

Sensor and Pre-actuator Connections on the ABE-7H12S21 Base with 1 Isolator per Channel

At a Glance

This is an overview of the sensor and actuator connections on the TELEFAST 2 base.

NOTE: The base is manufactured with a general-purpose, quick-blow fuse rated 6.3 A. To guarantee optimum protection, this fuse should be rated according to the application (connection to input or output functions) and the maximum current allowable in the base.

Type and rating of fuse to be fitted to the base:

- input functions: 0.5 A quick-blow
- output functions: 6.3A quick-blow on the ABE-7H12S21 base

Illustration

Description of the connection terminal blocks.

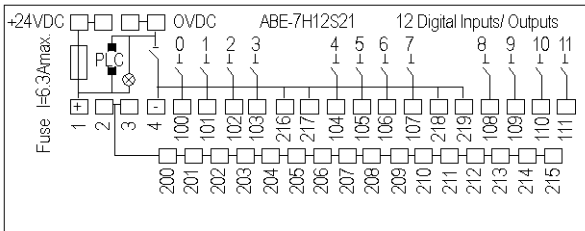

Illustration

Connections for input and output functions.

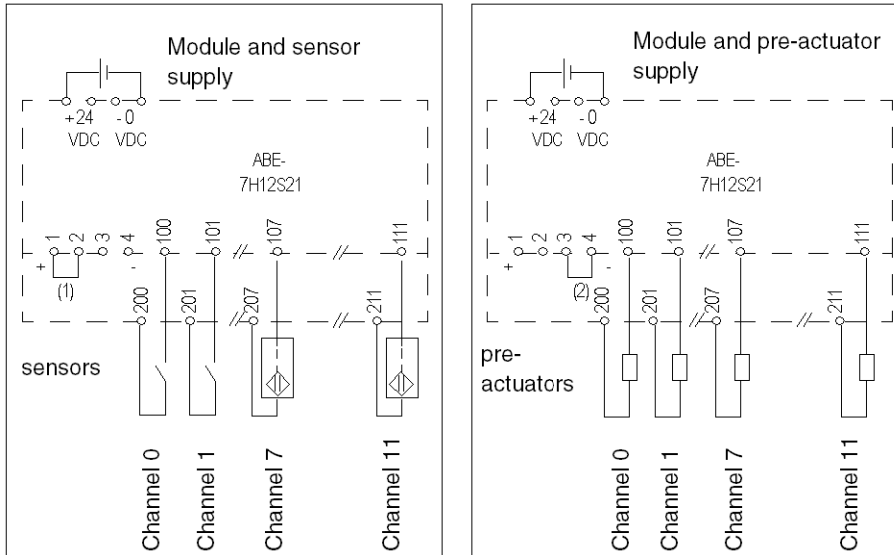

Connecting the common for sensors:

- In order to create the shared sensor supply, position the jumper (1) on terminals 1 and 2: terminals 200 to 215 will be on the '+' of the supply (positive logic inputs).

Terminals 216, 217, 218 and 219 are linked to the '-' polarity.

Connecting the common for pre-actuators:

- In order to create the shared supply for the pre-actuators, position the jumper (2) on terminals 3 and 4: terminals 200 to 215 will be on the '-' of the supply (positive logic outputs).

Terminals 216, 217, 218 and 219 are linked to the '+' polarity.

TELEFAST 2 ABE-7H16R30/16R31 Connection Bases

Aim of this section

This section introduces the connection bases **TELEFAST 2 ABE-7H16R30/16R31**.

Sensor and Pre-actuator Connections on the ABE-7H16R30/R31 Bases

At a Glance

This is an overview of the sensor connections on TELEFAST 2 bases.

NOTE: The bases are manufactured with a general-purpose, quick-blow fuse rated 2 A. To guarantee optimum protection, this fuse should be rated according to the application and the maximum current allowable in the base.

Type and rating of fuse to be fitted to the base:

- input functions: 0.5A quick-blow

Illustration

Description of the connection terminal blocks.

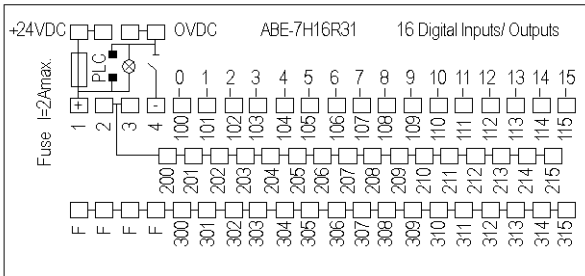

Illustration

Input function connections.

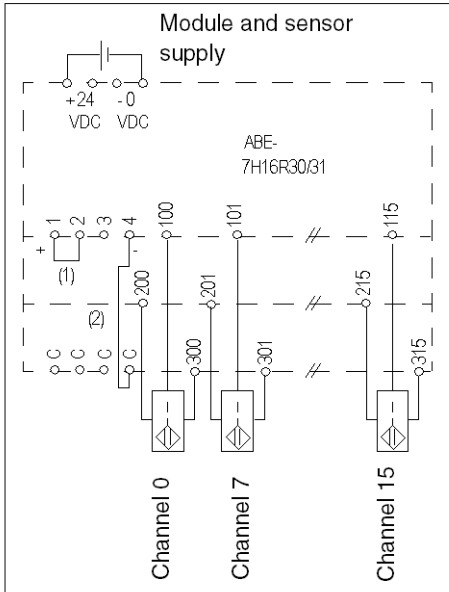

Connecting the common for sensors:

- to create the shared sensor supply:
 - position the jumper wire (1) on terminals 1 and 2: terminal blocks 200 to 215 will be at the "+" of the supply
 - link terminal 4 to one of the C terminals of the 3rd level (2): terminal blocks 300 to 315 will be at the "-" of the supply

NOTE: The ABE-7H16R30/R31 base can also be used for connecting actuators.

TELEFAST 2 ABE-7H12R50 Connection Base

Aim of this section

This section describes the connection base **TELEFAST 2 ABE-7H12R50**.

Sensor and Pre-actuator Connections on the ABE-7H12R50 Bases

At a Glance

This is an overview of the sensor and pre-actuator connections on the TELEFAST 2 base.

NOTE: The base is manufactured with a general-purpose, quick-blow fuse rated 6.3 A. To guarantee optimum protection, this fuse should be rated according to the application (connection to input or output functions) and the maximum current allowable in the base.

Type and rating of fuse to be fitted to the base:

- input functions: 0.5 A quick-blow
- output functions: 6.3 A quick-blow on the ABE-7H12R50 base

Illustration

Description of the connection terminal blocks.

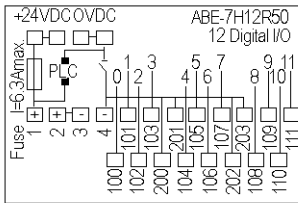

Illustration

Connections for input and output functions.

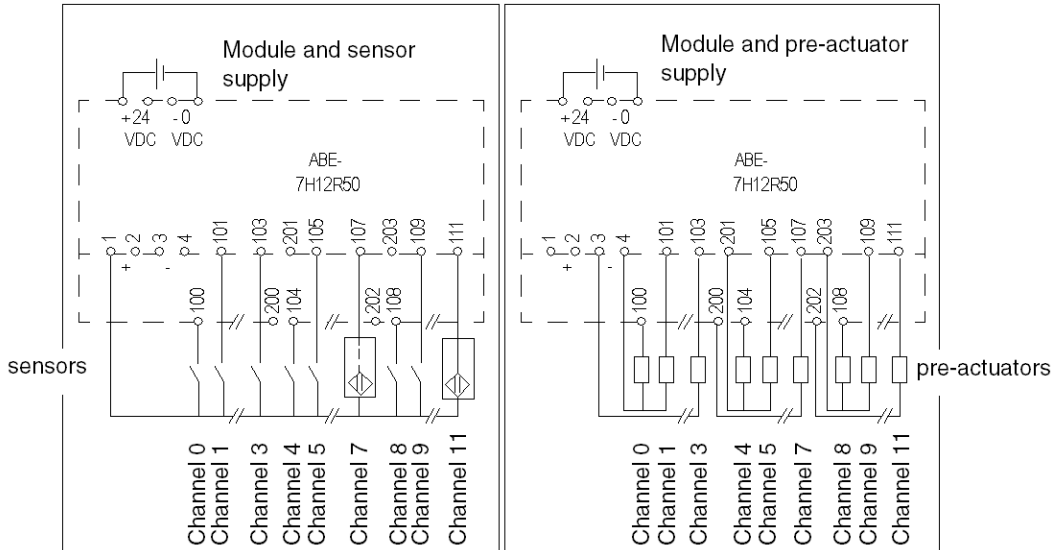

Connecting the common for sensors:

- onto terminals 1 or 2: sensors to the '+' of the supply (positive logic inputs).
Terminals 200, 201, 202 and 203 are linked to the '-' polarity

Connecting the common for pre-actuators:

- several terminals linked to the '-' polarity (3, 4, 200, 202, and 203) allow sharing in groups of 4 or 2 channels (positive logic outputs)

TELEFAST 2 ABE-7H16R50 Connection Base

Aim of this section

This section describes the connection base **TELEFAST 2 ABE-7H16R50**.

Sensor and Actuator Connections on the ABE-7H16R50 Base

At a Glance

This is an overview of the sensor and actuator connections on the TELEFAST 2 base.

NOTE: The base is manufactured with a general-purpose, fast-blow fuse rated 6.3 A. To guarantee optimum protection, this fuse should be rated according to the application (connection to input or output functions) and the maximum current allowable in the base.

Type and rating of fuse to be fitted to the base:

- input functions: 0.5A fast blow
- output functions: 2A fast blow on the ABE-7H16R50 base

Illustration

Description of the connection terminal blocks.

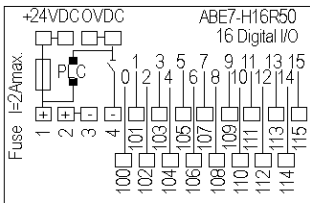

Illustration

Connections for input and output functions.

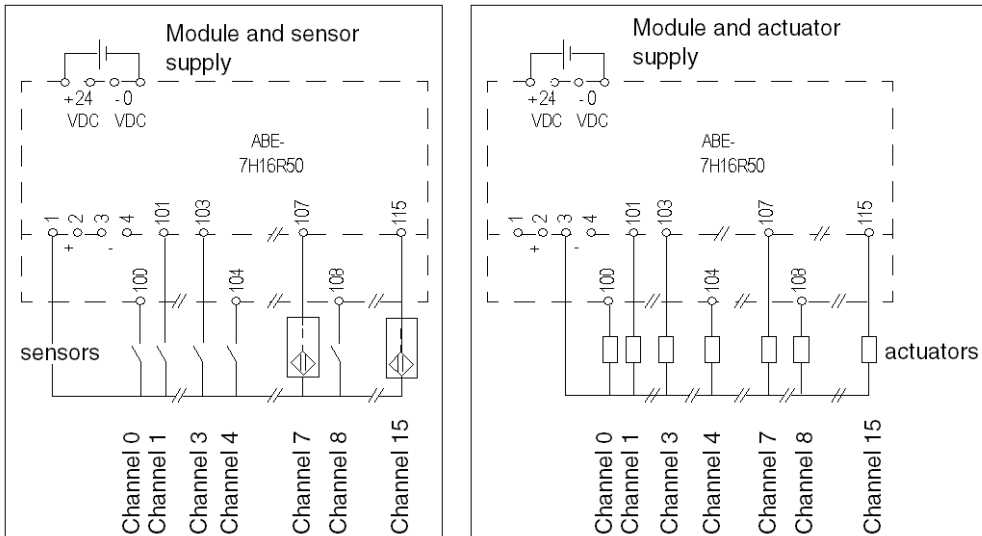

Connecting the common for sensors:

- onto terminals 1 or 2: sensors to the '+' of the supply (positive logic inputs)

Connecting the common for actuators:

- onto terminals 3 or 4: actuators to the '-' of the supply (positive logic outputs)

TELEFAST 2 ABE-7H16F43 Connection Base

Aim of this section

This section describes the connection base **TELEFAST 2 ABE-7H16F43**.

Actuator Connections on ABE-7H16F43 Output Base with One Fuse and One Isolator per Channel

At a Glance

This is an overview of the actuator connections on TELEFAST 2 bases.

Illustration

Description of the connection terminal blocks.

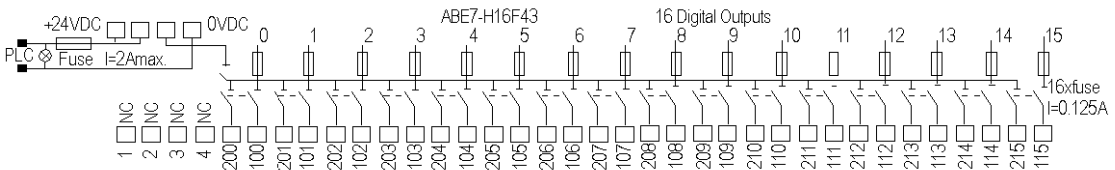

Illustration

Output connection functions.

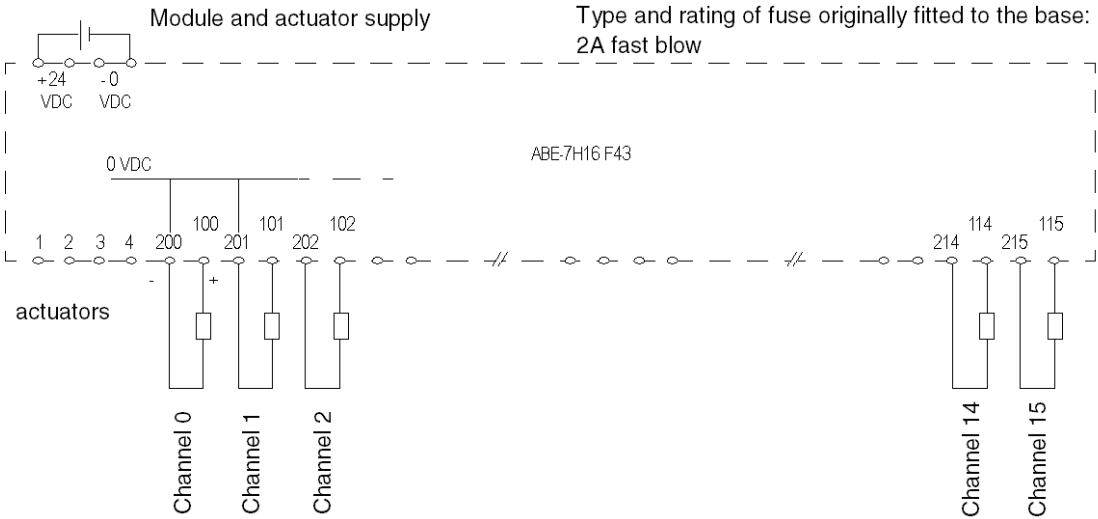

Functionality per channel:

- original fitted 0.125 A fuse
- isolator cuts the '-' and the channel signal simultaneously

NOTE: Terminals 200..215 are connected to the '-' polarity of the supply.

TELEFAST 2 ABE-7H16S43 Connection Base

Aim of this section

This section describes the connection base **TELEFAST 2 ABE-7H16S43**.

Sensor Connections on ABE-7H16S43 Output Base with One Fuse and One Isolator per Channel

At a Glance

This is an overview of the sensor connections on TELEFAST 2 bases.

Illustration

Description of the connection terminal blocks.

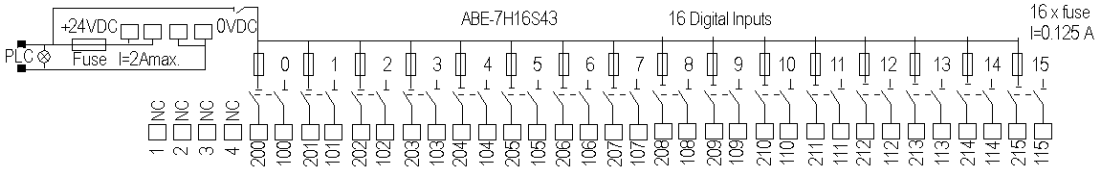

Illustration

Input function connections.

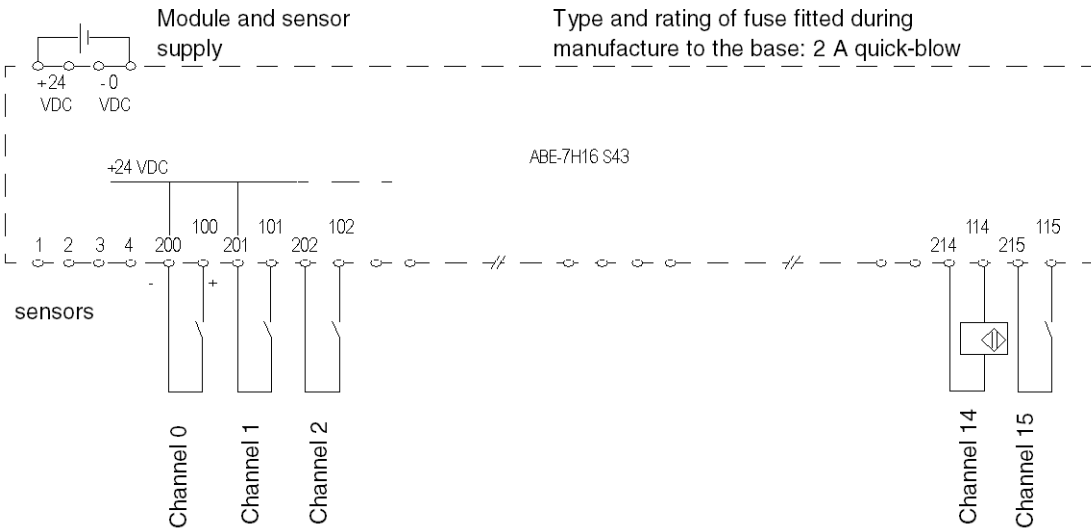

Functionality per channel:

- 0.125 A fuse fitted during manufacture
- isolator cuts the '+' and the channel signal simultaneously

NOTE: Terminals 200...215 are connected to the '+' polarity of the supply.

TELEFAST 2 Connection Base Accessories

Aim of this Section

This section introduces the TELEFAST 2 connection bases' range of accessories.

TELEFAST 2 Connection Base Accessories Catalog

At a Glance

This is an overview of the TELEFAST 2 connection base accessories catalog for discrete I/O modules.

Catalog

The table below shows the TELEFAST 2 connection base accessories catalog.

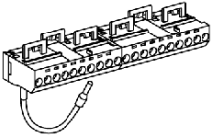
Product reference	Illustration	Description
Additional shunt terminal block		
ABE-7BV10		Terminal block fitted with 10 screw terminal blocks
ABE-7BV20		Terminal block fitted with 20 screw terminal blocks
Adapter base		
ABE-7ACC02		Enables the connection of 16 channels in 2 x 8-channel groups
Mounting kit		
ABE-7ACC01		Enables the bases to be mounted on monoblock mounting plates
Sealed cable lead-through		
ABE-7ACC84		Allows transit through cabinets without cutting the cables
Transit through cabinet		
ABE-7ACC83		40-pin connectors for 8/12 channels -> M23 cylindrical connector

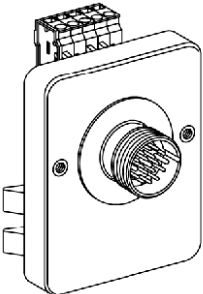
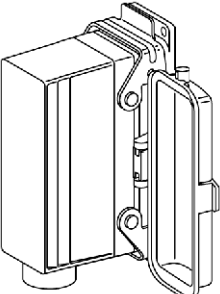
Product reference	Illustration	Description
ABE-7ACC82		40-pin connectors for 16 channels -> M23 cylindrical connector
ABE-7ACC80		40-pin connectors for 32 channels -> HARTING type connector
ABE-7ACC81		Plug-in connector for ABE-7ACC80
Removable continuity module		
ABE-7ACC20		Width 10 mm
ABE-7ACC21		Width 12.5 mm
Customer identification label marking software		
ABE-7LOGV10	-	-
5 x 20 quick-blow glass fuse		
ABE-7FU012		0.125 A
ABE-7FU050		0.5 A
ABE-7FU100		1 A
ABE-7FU200		2 A
ABE-7FU630		6.3 A
Adhesive marker holder		

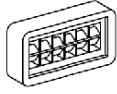
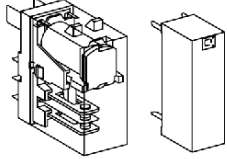
Product reference	Illustration	Description
AR1-SB3		For AB1-R. / AB1-G type markers
Relays for ABE-7R16T***, ABE-7P16T*** and ABE-7P16F*** bases		
ABR-7S*** (1)	ABE-7S3** and ABE-7S2** 	Output electromechanical relay (4)
ABS-7S*** (2)		Output static relay (4)
ABS-7E*** (3)		Input static relay (4)
<p>(1) For electrical characteristics, see Characteristics of the Removable ABR-7xxx Electromechanical Output Relays, page 336.</p> <p>(2) For electrical characteristics, see Characteristics of the Removable ABS-7Sxx Static Output Relays, page 338.</p> <p>(3) For electrical characteristics, see Characteristics of the Removable ABS-7Exx Static input Relays, page 337.</p> <p>(4) Contingency table of relays for bases, see Association Table for the Relays on ABE-7R16Txxx, ABE-7P16Txxx and ABE-7P16Fxxx Bases, page 334.</p>		

Association Table for the Relays on ABE-7R16Txxx, ABE-7P16Txxx and ABE-7P16Fxxx Bases

At a Glance

The table for comparison between the TELEFAST 2 **ABE-7R16T*****, **ABE-7P16T***** and **ABE-7P16F***** link bases and the electromagnetic or static relays is described here.

Compatibility Table

The table below shows the association possibilities for the electromagnetic or static relays on the TELEFAST 2 bases.

Bases ABE-7**		equipped with electromagnetic relays				not equipped with relays			
		R16T21•	R16T23•	R16T33•	R16-T370	P16T21•	P16T33•	P16-T318	P16F31•
Electromagnetic relays from ABR-7*** output									
10 mm	S21 1F	X	-	-	-	X	-	-	-
	S23 10F	X (1)	X	-	-	-	-	-	-
12.5 mm	S33 10F	-	-	X	-	-	X	X	-
	S37 20F	-	-	-	X	-	-	-	-
Static relays from ABS-S** output									
10 mm	C2E	X (1)	-	-	-	X	-	-	-
	A2M	X (1)	-	-	-	X	-	-	-
12.5 mm	C3BA	-	-	X (1)	-	-	X (2)	X	-
	C3E	-	-	X (1)	-	-	X	X	-
	A3M	-	-	X (1)	-	-	X	X	-
Static relays from ABS-7E** input									
12.5 mm	C3AL	-	-	-	-	-	-	-	X
	C3B2	-	-	-	-	-	-	-	X
	C3E2	-	-	-	-	-	-	-	X
	A3E5	-	-	-	-	-	-	-	X
	A3F5	-	-	-	-	-	-	-	X
	A3F6	-	-	-	-	-	-	-	X
	A3M5	-	-	-	-	-	-	-	X
	A3M6	-	-	-	-	-	-	-	X
ABE-7*** continuity block									
10 mm	ACC20	X	-	-	-	X	-	-	-
12.5 mm	ACC21	-	-	X	-	-	X	X	-
<p>X compatible</p> <p>- not compatible</p> <p>(1) relays can be in line</p> <p>(2) except on ABE-7P16T334</p>									

Characteristics of the Removable ABR-7xxx Electromechanical Output Relays

At a Glance

The general characteristics of the removable ABR-7*** electromechanical output relays for TELEFAST 2 bases are described in this section.

General Characteristics

This table shows the general characteristics of the ABR-7*** relays.

ABR-7*** reference		S21	S23	S33	S37	
Relay width		10 mm		12.5 mm		
Characteristics of the contacts						
Composition of the contacts		1 F	1 OF		2 OF	
Max. operating voltage according to IEC 947-5-1	Alternating	250 V		264 V		
	Direct	125 V				
Thermal current		4 A		5 A		
Frequency of current used		50/60 Hz				
Alternating current load	Resistive, load AC12	Voltage	230 VAC			
		Current	1.5 A	1.2 A	3 A	2.5 A
	Inductive load AC15	Voltage	230 VAC			
		Current	0.9 A	0.7 A	1.7 A	1.3 A
Direct current load	Resistive, load DC12	Voltage	24 VDC			
		Current	1.5 A	1.2 A	3 A	2.5 A
	Inductive load DC13, L/R = 10 ms	Voltage	24 VDC			
		Current	0.6 A	0.45 A	1.4 A	1 A
Minimum switching		Current	10 mA		100 mA	
		Voltage	5 V			
Response time		State 0 to 1	10 ms		13 ms	15 ms
		State 1 to 0	5 ms		13 ms	20 ms
Maximum speed of function loading		0.5 Hz				
Voltage assigned insulation		Coil/contact	300 V			
Voltage assigned shock resistance (1.2/50)		Coil/contact	2.5 kV			

(1)	for 0.5 x 10 ⁶ maneuvers
-----	-------------------------------------

Characteristics of the Removable ABS-7Exx Static input Relays

At a Glance

The general characteristics of the removable ABS-7E•• static input relays for TELEFAST 2 bases are described in this section.

General Characteristics

This table shows the general characteristics of the ABS-7E•• relays.

ABS-7E•• reference		C3AL	C3B2	C3E2	A3E5	A3F5	A3M5
Relay width		12.5 mm					
Command characteristics							
Assigned operating voltage (Us)	Direct	5 V	24 V	48 V	-		
	Alternating	-			48 V	110..130 V	230..240 V
Max. operating voltage (including ripple)		6 V	30 V	60 V	53 V	143 V	264 V
Max. current at Us		13.6 mA	15 mA		12 mA	8.3 mA	8 mA
State 1 guaranteed	Voltage	3.75 V	11 V	30 V	32 V	79 V	164 V
	Current	4.5 mA	6 mA		5 mA		4.5 mA
State 0 guaranteed	Voltage	2 V	5 V	10 V		30 V	40 V
	Current	0.09 mA	2 mA		1.5 mA	2 mA	
Maximum switching frequency (cyclic report 50%)		1000 Hz			25 Hz		
Complies with IEC1131-2		-	Type 2		Type 1		
Response time	State 0 to 1	0.05 ms			20 ms		
	State 1 to 0	0.4 ms			20 ms		
Voltage assigned to insulation	Input/output	300 V					
Voltage assigned to shock resistance (1.2/50)	Input/output	2.5 kV					

Characteristics of the Removable ABS-7Sxx Static Output Relays

At a Glance

The general characteristics of the removable ABS-7S•• static output relays for TELEFAST 2 bases are described in this section.

General Characteristics

This table shows the general characteristics of the ABS-7S•• relays.

ABS-7S•• reference			C2E	A2M	C3BA	C3E	A3M
Relay width			10 mm		12.5 mm		
Output circuit characteristics							
Voltage assigned to job		Direct	5..48 V	-	24 V	5..48 V	-
		Alternating	-	24..240 V	-		24..240 V
Max. voltage			57.6 VDC	264 VAC	30 VDC	60 VDC	264 VAC
Alternating current load	Resistive, load AC12	Current	-	0.5 A	-		2 A
	Direct current load	Resistive, load DC12	Current	0.5 A	-	2 A	1.5 A
Direct current load	Inductive load DC13	Current	-	-		0.3 A	-
	Filament lamp load DC6		-			10 W	-
Leakage current at state 0			<= 0.5 mA	<= 2 mA	<= 0.3 mA		<= 2 mA
Breakdown voltage at state 1			<= 1 V	<= 1.1 V	<= 0.3 V	<= 1.3 V	
Minimum current through channel			1 mA	10 mA	1 mA		10 mA
Response time		State 0 to 1	0.1 ms	10 ms	0.1 ms		10 ms
		State 1 to 0	0.6 ms	10 ms	0.02 ms	0.6 ms	10 ms
Switching frequency on inductive load			-		< 0.5 LI ²	-	
Voltage assigned to insulation		Input/output	300 V				
Voltage assigned to shock resistance (1.2/50)		Input/output	2.5 kV				

Discrete Input/Output Modules Software Implementation

What's in This Part

General Introduction to the Application-Specific Discrete Function	340
Configuration.....	342
Application-Specific Discrete Module Language	
Objects	354
Debugging	371
Diagnostics of the Modules	376

Subject of this Part

This part describes the application-specific discrete functions for Modicon Mx80 PLCs and describes their implementation with the Control Expert software.

General Introduction to the Application-Specific Discrete Function

What's in This Chapter

Overview..... 340

Subject of this Section

This chapter describes the application-specific discrete function on Modicon Mx80 PLCs.

Overview

Introduction

The software installation of the application-specific modules is carried out from various Control Expert editors in both online and offline modes.

If you do not have a processor to connect to, Control Expert allows you to carry out an initial test using the simulator. In this case there are differences in the installation, page 341.

The following order of installation phases is recommended but it is possible to change the order of certain phases (for example, starting with the configuration phase).

Installation Phases with Processor

The following table shows the various phases of installation with the processor.

Phase	Description	Mode
Declaration of variables	Declaration of IODDT-type variables for the application-specific modules and variables of the project	Offline / Online
Programming	Project programming	Offline / Online
Configuration	Declaration of modules	Offline
	Module channel configuration	
	Entry of configuration parameters	
Association	Association of IODDTs with the channels configured (variable editor)	Offline / Online

Phase	Description	Mode
Generation	Project generation (analysis and editing of links)	Offline
Transfer	Transfer project to PLC	Online
Adjustment	Project debugging from debug screens, animation tables	Online
Debugging	Modifying the program and adjustment parameters	
Documentation	Building documentation file and printing miscellaneous information relating to the project	Offline / Online
Operation/ Diagnostic	Displaying miscellaneous information necessary for supervisory control of the project	Online
	Diagnostic of project and modules	

Implementation Phases with Simulator

The following table shows the various phases of installation with the simulator.

Phase	Description	Mode
Declaration of variables	Declaration of IODDT-type variables for the application-specific modules and variables of the project	Offline / Online
Programming	Project programming	Offline / Online
Configuration	Declaration of modules	Offline
	Module channel configuration	
	Entry of configuration parameters	
Association	Association of IODDTs with the modules configured (variable editor)	Offline / Online
Generation	Project generation (analysis and editing of links)	Offline
Transfer	Transfer project to simulator	Online
Simulation	Program simulation without inputs/outputs	Online
Adjustment	Project debugging from debug screens, animation tables	Online
Debugging	Modifying the program and adjustment parameters	

Note: The simulator is only used for the discrete or analog modules.

Configuration

What's in This Chapter

Configuration of a Discrete Module: General Points	342
Discrete Input and Output Channel Parameters.....	347
Configuration of Discrete Module Parameters	350

Subject of this Section

This section describes the configuration of application-specific discrete modules for implementation.

Configuration of a Discrete Module: General Points

Subject of this Section

This section describes the basic operations required to configure a Modicon X80 discrete module.

Discrete Module Configuration Screen in Modicon Mx80 local rack

At a Glance

The configuration screen is a graphic tool designed for configuring a module selected in a rack. It displays the parameters defined for this module's channels, and enables their modification in offline mode and on-line mode.

It also provides access to the debug screen (in on-line mode only).

NOTE: It is not possible to configure a module by programming using direct language objects %KW, page 364; these words are accessible in read only format.

NOTE: With module firmware 2.4 or later, you can access the modules either via topological or State RAM addresses.

Please refer to *Memory Tab* (see EcoStruxure™ Control Expert, Operating Modes) and *Topological/State RAM Addressing of Modicon X80 Discrete Modules*, page 380.

Illustration

This screen enables the display and modification of parameters in offline mode, as well as debug in online mode.

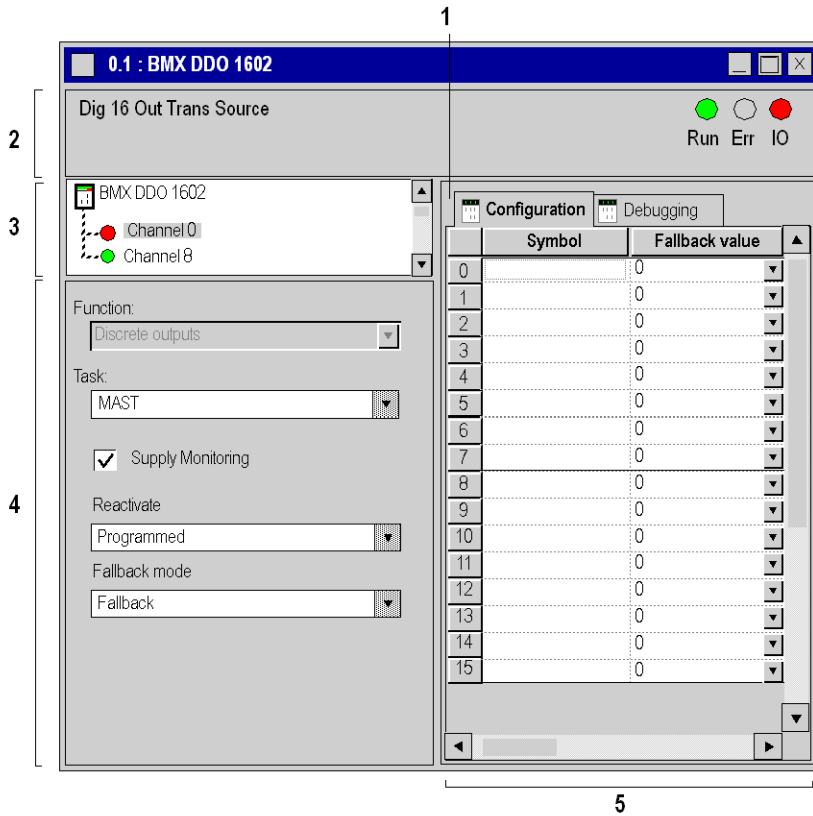

Description

The next table shows the various elements of the configuration screen and their functions.

Address	Element	Function
1	Tabs	The tab in the foreground indicates the mode in progress (Configuration in this example). Every mode can be selected using the respective tab. The Debug mode is only accessible in online mode.
2	Module area	Specifies the abbreviated heading of the module. In online mode, this area also includes the three LEDs: Run , Err and IO .

Address	Element	Function
3	Channel area	<p>Allows you:</p> <ul style="list-style-type: none"> • by clicking on the reference number, to display the tabs: <ul style="list-style-type: none"> ◦ Description which gives the characteristics of the device ◦ I/O Objects, (see EcoStruxure™ Control Expert, Operating Modes) which is used to pre-symbolize the input/output objects ◦ Fault which shows the device status (in on-line mode) • to select a channel • to display the Symbol, name of the channel defined by the user (using the variable editor)
4	General parameters area	<p>Allows you to select the associated function and task in groups of 8 channels:</p> <ul style="list-style-type: none"> • Function: defines the configuration/de-configuration of the channel group selected (other than groups 0 to 7) • Task: defines the task (MAST, FAST) in which channel default exchange objects will be exchanged <p>The check box Supply monitoring defines the active or inactive state of the external power supply monitoring (available only on some discrete modules).</p> <p>The Reset and Fallback mode drop-down menus enable you to configure the output reset and output fallback mode (available only on some discrete modules).</p>
5	Configuration zone	<p>Enables the configuration of parameters for the various channels. This field includes various items, displayed according to the selected discrete module.</p> <p>The Symbol column displays the symbol associated with the channel when it has been defined by the user (using the variable editor).</p>

Discrete Module Configuration Screen in X80 Drop

At a Glance

The various available screens for the discrete modules are:

- **Configuration** screen
- **Type**

Illustration

This screen shows the configuration screen:

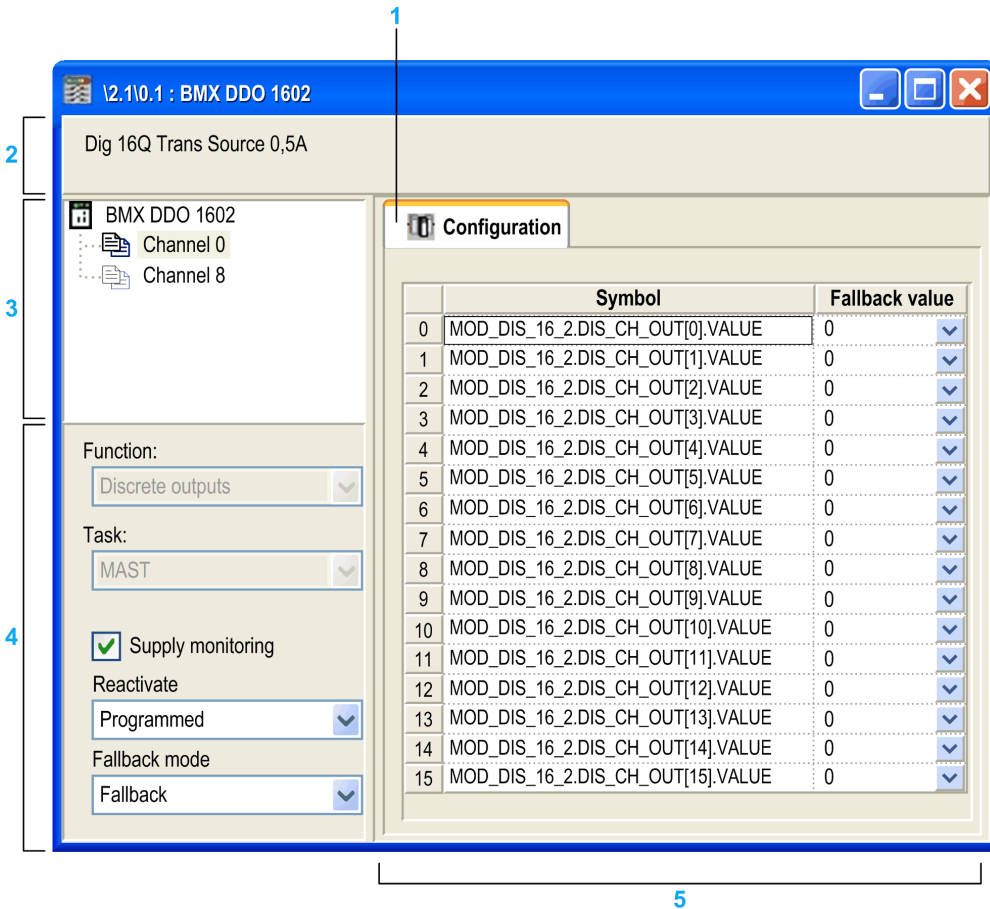

Description

This table shows the various elements of the configuration screen and their functions.

Address	Element	Function
1	Tabs	<p>The tab in the foreground indicates the mode in progress (Configuration in this example). Every mode can be selected using the respective tab:</p> <ul style="list-style-type: none"> • Overview • Configuration • Device DDT which gives the Device DDT, page 365 name and type of the device
2	Module area	Specifies the abbreviated heading of the module.
3	Channel area	<p>Allows you:</p> <ul style="list-style-type: none"> • by clicking on the reference number, to display the tabs: <ul style="list-style-type: none"> ◦ Description which gives the characteristics of the device • to select a channel • to display the Symbol, name of the channel defined by the user (using the variable editor) <p>NOTE: All channel are activated and a channel cannot be de-activated to None.</p>
4	General parameters area	<p>Allows you to select the associated function and task in groups of 8 channels:</p> <ul style="list-style-type: none"> • Function: defines the configuration/de-configuration of the channel group selected (other than groups 0 to 7) • Task: defines the (MAST) task in which channel default exchange objects are exchanged <p>The check box Supply monitoring defines the active or inactive state of the external power supply monitoring for the 16-channel group selected (available only on 16, 32 and 64 channel discrete modules).</p> <p>In a user application the <code>WRITE_CMD</code>(in a X80 drop) or the <code>WRITE_CMD_QX</code>(in an EIO drop) can also defines the active or inactive state of the external power supply monitoring and overrides the Supply monitoring setting.</p> <p><code>WRITE_CMD_QX</code>only works over the first 8 channels (0...7, 16...23, 32...39 and 48...55) of the 16 channel groups, but affects all 16 channels of the group.</p> <p><code>WRITE_CMD</code>works over any of the 16 channels of a channel group and affects all 16 channels of the group. <code>WRITE_CMD</code>also allows reactivation of tripped outputs.</p> <p>The Reactivate and Fallback mode drop-down menus enable you to configure the output reset and output fallback mode (available only on some discrete modules).</p>
5	Configuration zone	<p>Enables the configuration of parameters for the various channels. This field includes various items, displayed according to the selected discrete module.</p> <p>The Symbol column displays the symbol associated with the channel when it has been defined by the user (using the variable editor).</p>

Discrete Input and Output Channel Parameters

Subject of this Section

This section presents the various parameters of input and output channels for discrete modules.

Discrete Input Parameters on the Rack

At a Glance

The discrete input module includes different parameters per channel. The channels are divided into blocks of 8 or 16 consecutive channels.

Parameters

The following table displays the parameters available for each in-rack discrete input module.

Reference Module	Number of inputs	Associated task (8-channel group)	Function (8-channel group)	Supply monitoring (16-channel group)	Wiring Check (Input by input)
BMX DDI 1602	16	Mast / Fast	Discrete inputs / None	Active / Inactive	–
BMX DDI 1603	16	Mast / Fast	Discrete inputs / None	Active / Inactive	–
BMX DDI 1604T	16	Mast / Fast	Discrete inputs / None	Active / Inactive	–
BMX DDI 3202 K	32	Mast / Fast	Discrete inputs / None	Active / Inactive	–
BMX DDI 3203	32	Mast / Fast	Discrete inputs / None	Active / Inactive	–
BMX DDI 3232	32	Mast / Fast	Discrete inputs / None	Active / Inactive	–
BMX DDI 6402 K	64	Mast / Fast	Discrete inputs / None	Active / Inactive	–
BMX DAI 0805	8	Mast / Fast	Discrete inputs	Active / Inactive	–
BMX DAI 0814	8	Mast / Fast	Discrete inputs	–	–
BMX DAI 1602	16	Mast / Fast	Discrete inputs / None	Active / Inactive	–
BMX DAI 1603	16	Mast / Fast	Discrete inputs / None	Active / Inactive	–
BMX DAI 1604	16	Mast / Fast	Discrete inputs / None	Active / Inactive	–
BMX DAI 1614	16	Mast / Fast	Discrete inputs / None	Inactive / Active	Inactive / Active

Reference Module	Number of inputs	Associated task (8-channel group)	Function (8-channel group)	Supply monitoring (16-channel group)	Wiring Check (Input by input)
BMX DAI 1615	16	Mast / Fast	Discrete inputs / None	Inactive / Active	Inactive / Active
BMX DDM 16022	8 (inputs)	Mast / Fast	Discrete inputs	Active / Inactive	–
BMX DDM 16025	8 (inputs)	Mast / Fast	Discrete inputs	Active / Inactive	–
BMX DDM 3202 K	16 (inputs)	Mast / Fast	Discrete inputs / None	Active / Inactive	–

NOTE: Parameters indicated in bold characters are part of the default configuration.

NOTE: The BMX DDM 16022 and BMX DDM 16025 discrete mixed input/output modules have 2 groups of 8 channels. The input group is represented by channels 0 to 7 and the output group is represented by channels 16 to 23.

Discrete Output Parameters for 8-Channel Modules in Rack

At a Glance

The discrete output modules include several parameters per channel. The channels are divided into blocks of 8 or 16 consecutive channels.

Parameters

The following table displays the parameters available for each of the discrete output module.

		8-channel group				16-channel group	Channel by channel
Reference Module	Number of outputs	Reset	Associated task	Fallback mode	Function	Supply monitoring	Fall-back value
BMX DAO 1605	16	Programmed / Automatic	Mast / Fast	Fallback / Maintain	Discrete output / None	Active / Inactive	0 / 1
BMX DAO 1615	16	Programmed / Automatic	Mast / Fast	Fallback / Maintain	Discrete output / None	Active / Inactive	0 / 1

		8-channel group				16-channel group	Channel by channel
Reference Module	Number of outputs	Reset	Associated task	Fallback mode	Function	Supply monitoring	Fall-back value
BMX DDM 16022	8 (outputs)	Programmed / Automatic	Mast / Fast	Fallback / Maintain	Discrete outputs / None	Active / Inactive	0 / 1
BMX DDM 16025	8 (outputs)	-	Mast / Fast	Fallback / Maintain	Discrete outputs / None	Active / Inactive	0 / 1
BMX DDM 3202 K	16 (outputs)	Programmed / Automatic	Mast / Fast	Fallback / Maintain	Discrete outputs / None	Active / Inactive	0 / 1
BMX DDO 1602	16	Programmed / Automatic	Mast / Fast	Fallback / Maintain	Discrete outputs / None	Active / Inactive	0 / 1
BMX DDO 1612	16	Programmed / Automatic	Mast / Fast	Fallback / Maintain	Discrete output / None	Active / Inactive	0 / 1
BMX DDO 3202 K	32	Programmed / Automatic	Mast / Fast	Fallback / Maintain	Discrete outputs / None	Active / Inactive	0 / 1
BMX DDO 6402 K	64	Programmed / Automatic	Mast / Fast	Fallback / Maintain	Discrete outputs / None	Active / Inactive	0 / 1
BMX DRA 0804T	8	-	Mast / Fast	Fallback / Maintain	Discrete outputs	-	0 / 1
BMX DRA 0805	8	-	Mast / Fast	Fallback / Maintain	Discrete outputs	-	0 / 1
BMX DRA 0815	8	-	Mast / Fast	Fallback / Maintain	Discrete outputs	-	0 / 1
BMX DRA 1605	16	-	Mast / Fast	Fallback / Maintain	Discrete outputs / None	-	0 / 1
BMX DRC 0805	8	-	Mast / Fast	Fallback / Maintain	Discrete outputs	-	0 / 1

NOTE: The parameters in bold correspond to the parameters configured by default.

NOTE: The BMX DDM 16022 and BMX DDM 16025 discrete mixed input/output modules have 2 groups of 8 channels. The input group is represented by channels 0 to 7 and the output group is represented by channels 16 to 23.

Configuration of Discrete Module Parameters

Subject of this Section

This section presents general rules for implementing various configuration parameters for discrete input/output channels.

How to Modify the Task Parameter

At a Glance

This parameter defines the processor task where input acquisitions and output updates are performed.

The task is defined for 8 consecutive channels in the case of on-rack discrete modules.

The possible choices are as follows:

- **MAST** task
- **FAST** task

NOTE: Modifying the Task parameter is only possible in off-line mode.

Procedure

The following table shows how to define the type of task assigned to module channels.

Step	Action
1	Open the desired module configuration screen.
2	Click on the Task button of the drop-down menu to assign a task to the group you wish. Result: The following list appears. 
3	Choose the desired task.
4	Confirm the modification with the Edit > Validate menu command.

How to Modify the External Power Supply Error Monitoring Parameter

At a Glance

This parameter defines the status (activation or deactivation) of external power supply error monitoring.

It runs in groups of 16 consecutive channels.

Monitoring is active by default (box checked).

Procedure

The following table shows how to disable or enable the external power supply monitoring function.

Step	Action
1	Open the desired module configuration screen.
2	Check the Supply monitor box in the General Parameters area. Result : The I/O editor window appears. Click OK .
3	Validate the change by clicking Edit > Validate .

How to Modify the Fallback Mode Parameter

At a Glance

This parameter defines the fallback mode adopted by outputs when the PLC switches to **STOP** due to:

- a processor error
- a rack connection error
- an inter-rack cable connection error
- a STOP command in Control Expert.

The modes are as follows:

Mode	Meaning
Fallback	Channels are set to 0 or 1 according to the defined fallback value for the corresponding 8-channel group.
Maintenance	The outputs remain in the status they were in before switching to Stop .

Procedure

The following table shows the procedure for defining the fallback mode to be assigned to a channel group.

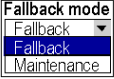
Step	Action
1	Open the desired module configuration screen.
2	For the desired channel group, click on the arrow of the Fallback mode drop-down menu. Result : The following list appears. 
3	Select the desired fallback mode.
4	For Fallback mode, configure each channel of the selected group. To do this, click on the drop-down menu arrow of the channel to be configured, located in the Fall Back Value column.
5	Click on the desired value (0 or 1).
6	Confirm the modification with the Edit > Validate menu command.

How to Modify the Output Reset Parameter

At a Glance

This parameter defines the reactivation mode of disconnected outputs.

The modes are as follows.

Mode	Meaning
Programmed	Reactivation is executed with a command from the PLC application or through the appropriate debug screen. Remark : In order to avoid repeated reactivations, the module ensures an automatic 10s delay between two resets.
Automatic	The reactivation is executed automatically every 10s until the error disappears.

The reactivation mode is defined for 8-channel groups.

Procedure

The following table shows the procedure for defining the module output channel reset mode.

Step	Action
1	Open the desired module configuration screen.
2	<p>For the desired channel group, click on the arrow of the Reactivate drop-down menu.</p> <p>Result : The following list appears.</p>  <p>The screenshot shows a small window titled "Reactivate" with a drop-down arrow. The menu is open, showing three options: "Programmed" (highlighted in blue), "Programmed", and "Automatic".</p>
3	Select the required reactivation mode.
4	Validate the modification by clicking Edit > Confirm .

Application-Specific Discrete Module Language Objects

What's in This Chapter

Language Objects and IODDT	354
Discrete Module IODDTs and Device DDTs.....	355

Subject of this Section

This chapter describes the language objects associated with application-specific discrete modules from various IODDT.

Language Objects and IODDT

Subject of this Section

This section provides general information about language objects and IODDTs for Discrete.

Description of the Discrete Function Objects Languages

General Points

Discrete modules have different associated IODDTs.

The IODDTs are predefined by the manufacturer. They contain input/output languages objects belonging to a channel of a specific application module.

There are 4 IODDT types for the discrete modules:

- T_DIS_IN_GEN
- T_DIS_IN_STD
- T_DIS_OUT_GEN
- T_DIS_OUT_STD

NOTE: IODDT variables may be created in two ways:

- using the **I/O objects** (see EcoStruxure™ Control Expert, Operating Modes) tab
- using the Data Editor

Language Object Types

Each IODDT contains a group of language objects which are used to control them and check their operation.

There are two types of language objects:

- **Implicit Exchange Objects**, which are automatically exchanged at each cycle pass of the task associated to the module
- **Explicit Exchange Objects**, which are exchanged upon demand from the application, while using explicit exchange instructions

Implicit exchanges concern the module inputs/outputs: measurement, information, and operation results.

Explicit exchanges enable module configuration and diagnosis.

NOTE: In order to avoid several simultaneous explicit exchanges for the same channel, it is necessary to test the value of the word EXCH_STS of the IODDT associated to the channel before to call EF using this channel.

Discrete Module IODDTs and Device DDTs

Subject of this Section

This section presents the different IODDT languages objects related to discrete input/output modules and the Device DDTs.

IODDT Links

IODDT Link Table

This table describes the IODDT linked to each discrete input/output module:

Module Reference	IODDTs linked to discrete module			
	T_DIS_IN_GEN	T_DIS_IN_STD	T_DIS_OUT_GEN	T_DIS_OUT_STD
BMX DDI 1602	x	x	-	-
BMX DDI 1603	x	x	-	-
BMX DDI 1604T	x	x	-	-
BMX DDI 3202 K	x	x	-	-
BMX DDI 3203	x	x	-	-
BMX DDI 3232	x	x	-	-

Module Reference	IODDTs linked to discrete module			
	T_DIS_IN_GEN	T_DIS_IN_STD	T_DIS_OUT_GEN	T_DIS_OUT_STD
BMX DDI 6402 K	x	x	-	-
BMX DAI 1602	x	x	-	-
BMX DAI 1603	x	x	-	-
BMX DAI 1604	x	x	-	-
BMX DAI 1614	x	x	-	-
BMX DAI 1615	x	x	-	-
BMX DAI 0805	x	x	-	-
BMX DAI 0814	x	x	-	-
BMX DDO 1602	-	-	x	x
BMX DDO 1612	-	-	x	x
BMX DDO 3202 K	-	-	x	x
BMX DDO 6402 K	-	-	x	x
BMX DRA 0804T	-	-	x	x
BMX DRA 0805	-	-	x	x
BMX DRA 0815	-	-	x	x
BMX DRA 1605	-	-	x	x
BMX DRC 0805	-	-	x	x
BMX DAO 1605	-	-	x	x
BMX DAO 1615	-	-	x	x
BMX DDM 16022	x	x	x	x
BMX DDM 16025	x	x	x	x
BMX DDM 3202 K	x	x	x	x
X: Linked -: Not linked				

Details About T_DIS_IN_GEN Type IODDT Implicit Object Exchange

At a glance

This section describes T_DIS_IN_GEN type IODDT Implicit Object Exchange that applies to all discrete input modules.

Input Flag

The following table presents the `VALUE (%I.r.m.c)` bit meaning.

Standard symbol	Type	Access	Meaning	Address
<code>VALUE</code>	<code>EBOOL</code>	R	Indicates that the status of the sensor controlling the input channel <code>c</code> .	<code>%I.r.m.c</code>

Error Bit

The following table presents the `CH_ERROR (%I.r.m.c.ERR)` bit meaning.

Standard symbol	Type	Access	Meaning	Address
<code>CH_ERROR</code>	<code>BOOL</code>	R	Indicates that <code>c</code> input channel is in error.	<code>%I.r.m.c.ERR</code>

Details About `T_DIS_IN_STD` Type IODDT Implicit Object Exchange

At a Glance

This section presents IODDT implicit exchange objects of the `T_DIS_IN_STD`-type applicable to discrete input modules.

Input Flag

The following table shows the `VALUE (%I.r.m.c)` bit meaning.

Standard symbol	Type	Access	Meaning	Address
<code>VALUE</code>	<code>EBOOL</code>	R	Indicates that the status of the sensor controlling the input channel <code>c</code> .	<code>%I.r.m.c</code>

Error Bit

The following table presents the `CH_ERROR (%I.r.m.c.ERR)` bit meaning.

Standard symbol	Type	Access	Meaning	Address
<code>CH_ERROR</code>	<code>BOOL</code>	R	Indicates that <code>c</code> input channel is in error.	<code>%I.r.m.c.ERR</code>

Details About T_DIS_IN_STD Type IODDT Explicit Object Exchange

At a Glance

This section presents IODDT explicit exchange objects of the `T_DIS_IN_STD` type applicable to discrete input modules. This section includes the word type objects whose bits have a specific meaning. These objects are explained in detail below.

Example of a declaration of a variable:

`IODDT_VAR1` of type `T_DIS_INT_STD`

NOTE: In general, the meaning of the bits is given for bit status 1. In specific cases an explanation is given for each status of the bit.

NOTE: Not all bits are used.

Execution Indicators for an Explicit Exchange: EXCH_STS

The following table shows exchange control bit meanings for channel `EXCH_STS` (%MWr.m.c.0).

Standard symbol	Type	Access	Meaning	Address
<code>STS_IN_PROGR</code>	BOOL	R	Read channel status words in progress	%MWr.m.c.0.0
<code>CMD_IN_PROGR</code>	BOOL	R	Command parameter exchange in progress	%MWr.m.c.0.1

Explicit Exchange Report: EXCH_RPT

The table below presents the meaning of the `EXCH_RPT` exchange report bits (%MWr.m.c.1).

Standard symbol	Type	Access	Meaning	Address
<code>STS_ERR</code>	BOOL	R	Error in reading status words of the channel (1 = error)	%MWr.m.c.1.0
<code>CMD_ERR</code>	BOOL	R	Error during a command parameter exchange (1 = error)	%MWr.m.c.1.1

Standard Channel Status: CH_FLT

The table below shows the meaning of the bits of the status word `CH_FLT` (%MWr.m.c.2). Reading is performed by a `READ_STS` (`IODDT_VAR1`).

Standard symbol	Type	Access	Meaning	Number
TRIP	BOOL	R	External event: Tripped	%MWr.m.c.2.0
FUSE	BOOL	R	External event: Fuse	%MWr.m.c.2.1
BLK	BOOL	R	Terminal block incorrectly wired	%MWr.m.c.2.2
EXT_PS_FLT	BOOL	R	External supply event	%MWr.m.c.2.3
INTERNAL_FLT	BOOL	R	Internal event module inoperative	%MWr.m.c.2.4
CONF_FLT	BOOL	R	Hardware or software configuration error	%MWr.m.c.2.5
COM_FLT	BOOL	R	Communication interruption	%MWr.m.c.2.6
SHORT_CIRCUIT	BOOL	R	External event: Short-circuit on a channel	%MWr.m.c.2.8
LINE_FLT	BOOL	R	Open wire detection ⁽¹⁾	%MWr.m.c.2.9
(1) Only for BMX DAI 1614 and BMX DAI 1615 modules				

Status Word: CH_CMD

The table below shows the CH_CMD (%MWr.m.c.3) status word bit meanings. The command is made by a WRITE_CMD (IODDT_VAR1).

Standard symbol	Type	Access	Meaning	Number
PS_CTRL_DIS	BOOL	R/W	Disable control of the external supply.	%MWr.m.c.3.1
PS_CTRL_EN	BOOL	R/W	Enable control of the external supply.	%MWr.m.c.3.2

NOTE: The control of the external power supply is managed to enable or disable a group of 16-channels from the PLC application and through a WRITE_CMD instruction addressing the 1st channel of 16-channel group (that is, channel 0, 16, 32, 46). However this command does not work with the last eight channels of the 16-channel groups (that is, channels 8..15, 24..31, 40..47, 56..63).

Details About T_DIS_OUT_GEN Type IODDT Implicit Object Exchange

At a Glance

This section presents T_DIS_OUT_GEN type IODDT Implicit Object Exchange that applies to discrete output modules.

Output Flag

The following table presents the VALUE (%Qr.m.c) bit meaning.

Standard symbol	Type	Access	Meaning	Number
VALUE	EBOOL	R/W	Indicates the status of the c output channel	%Qr.m.c

Error Bit

The following table presents the `CH_ERROR` (%lr.m.c.ERR) bit meaning.

Standard symbol	Type	Access	Meaning	Number
CH_ERROR	BOOL	R	Indicates that c output channel is in error	%lr.m.c.ERR

Details About T_DIS_OUT_STD Type IODDT Implicit Object Exchange

At a Glance

This section presents `T_DIS_OUT_STD` type IODDT Implicit Object Exchange that applies to discrete output modules.

Output Flag

The following table presents the `VALUE` (%Qr.m.c) bit meanings.

Standard symbol	Type	Access	Meaning	Number
VALUE	EBOOL	R/W	Indicates the status of the c output channel	%Qr.m.c

Error Bit

The following table presents the `CH_ERROR` (%lr.m.c.ERR) bit meaning.

Standard symbol	Type	Access	Meaning	Number
CH_ERROR	BOOL	R	Indicates that c input channel is in error	%lr.m.c.ERR

Details About T_DIS_OUT_STD Type IODDT Explicit Object Exchange

At a Glance

This section presents T_DIS_OUT_STD type IODDT Explicit Object Exchange that applies to discrete output modules. It includes the word type objects whose bits have a specific meaning. These objects are explained in detail below.

Example of a declaration of a variable:

IODDT_VAR1 of the T_DIS_OUT_STD type

NOTE: In general, the meaning of the bits is given for bit status 1. In specific cases an explanation is given for each status of the bit.

NOTE: Not all bits are used.

Execution Indicators for an Explicit Exchange: EXCH_STS

The table below shows the meanings of channel exchange control bits from channel EXCH_STS (%MWr.m.c.0).

Standard symbol	Type	Access	Meaning	Address
STS_IN_PROGR	BOOL	R	Read channel status words in progress	%MWr.m.c.0.0
CMD_IN_PROGR	BOOL	R	Command parameter exchange in progress	%MWr.m.c.0.1

Explicit Exchange Report: EXCH_RPT

The table below presents the meaning of the EXCH_RPT exchange report bits (%MWr.m.c.1).

Standard symbol	Type	Access	Meaning	Address
STS_ERR	BOOL	R	Error in reading status words of the channel (1 = error)	%MWr.m.c.1.0
CMD_ERR	BOOL	R	Error during a command parameter exchange (1 = error)	%MWr.m.c.1.1

Standard Channel Status: CH_FLT

The table below shows the meaning of the bits of the status word CH_FLT (%MWr.m.c.2). Reading is performed by a READ_STS (IODDT_VAR1).

Standard symbol	Type	Access	Meaning	Number
TRIP	BOOL	R	External event: Tripped	%MWr.m.c.2.0
FUSE	BOOL	R	External event: Fuse	%MWr.m.c.2.1
BLK	BOOL	R	Terminal block incorrectly wired	%MWr.m.c.2.2
EXT_PS_FLT	BOOL	R	External supply event	%MWr.m.c.2.3
INTERNAL_FLT	BOOL	R	Internal event module inoperative	%MWr.m.c.2.4
CONF_FLT	BOOL	R	Hardware or software configuration error	%MWr.m.c.2.5
COM_FLT	BOOL	R	Communication interruption	%MWr.m.c.2.6
SHORT_CIRCUIT	BOOL	R	External event: Short-circuit on a channel	%MWr.m.c.2.8
LINE_FLT	BOOL	R	Reserved for evolution	%MWr.m.c.2.9

Status word: CH_CMD

The table below shows the CH_CMD (%MWr.m.c.3) status word bit meanings. The command is made by a WRITE_CMD (IODDT_VAR1).

Standard symbol	Type	Access	Meaning	Address
REAC_OUT	BOOL	R/W	Reactivation of tripped outputs (protected outputs)	%MWr.m.c.3.0
PS_CTRL_DIS	BOOL	R/W	Inhibit control of external supply	%MWr.m.c.3.1
PS_CTRL_EN	BOOL	R/W	Validation of the external supply control	%MWr.m.c.3.2

NOTE: This object is specific to output modules with reactivation.

NOTE: The control of the external power supply is managed to enable or disable a group of 16-channels from the PLC application and through a WRITE_CMD instruction addressing the 1st channel of 16-channel group (i.e. channel 0, 16, 32, 46). However this command does not work with the last eight channels of the 16-channel groups (i.e. channels 8..15, 24..31, 40..47, 56..63).

Details of the Language Objects of the IODDT of Type T_GEN_MOD

Introduction

The Modicon X80 modules have an associated IODDT of type T_GEN_MOD.

Observations

In general, the meaning of the bits is given for bit status 1. In specific cases an explanation is given for each status of the bit.

Some bits are not used.

List of Objects

The table below presents the objects of the IODDT.

Standard Symbol	Type	Access	Meaning	Address
MOD_ERROR	BOOL	R	Module detected error bit	%I.r.m.MOD.ERR
EXCH_STS	INT	R	Module exchange control word	%MWr.m.MOD.0
STS_IN_PROGR	BOOL	R	Reading of status words of the module in progress	%MWr.m.MOD.0.0
EXCH_RPT	INT	R	Exchange report word	%MWr.m.MOD.1
STS_ERR	BOOL	R	Event when reading module status words	%MWr.m.MOD.1.0
MOD_FLT	INT	R	Internal detected errors word of the module	%MWr.m.MOD.2
MOD_FAIL	BOOL	R	module inoperable	%MWr.m.MOD.2.0
CH_FLT	BOOL	R	Inoperative channel(s)	%MWr.m.MOD.2.1
BLK	BOOL	R	Terminal block incorrectly wired	%MWr.m.MOD.2.2
CONF_FLT	BOOL	R	Hardware or software configuration anomaly	%MWr.m.MOD.2.5
NO_MOD	BOOL	R	Module missing or inoperative	%MWr.m.MOD.2.6
EXT_MOD_FLT	BOOL	R	Internal detected errors word of the module (Fipio extension only)	%MWr.m.MOD.2.7
MOD_FAIL_EXT	BOOL	R	Internal detected error, module unserviceable (Fipio extension only)	%MWr.m.MOD.2.8
CH_FLT_EXT	BOOL	R	Inoperative channel(s) (Fipio extension only)	%MWr.m.MOD.2.9
BLK_EXT	BOOL	R	Terminal block incorrectly wired (Fipio extension only)	%MWr.m.MOD.2.10
CONF_FLT_EXT	BOOL	R	Hardware or software configuration anomaly (Fipio extension only)	%MWr.m.MOD.2.13
NO_MOD_EXT	BOOL	R	Module missing or inoperative (Fipio extension only)	%MWr.m.MOD.2.14

Modicon X80 Discrete I/O Module Configuration Constants

Module level constants

The table following presents the %KW common for each channel group of the module:

Object	Type	Detail	Channel group							
			0-7 1 st grp	8-15 2 nd grp	16-23 3 rd grp	24-31 4 th grp	32-39 5 th grp	40-47 6 th grp	48-55 7 th grp	56-63 8 th grp
%KW.r.m.c.0 with c = 0, 8, 16, 24, 32, 40, 48, 56.	INT	For each channel group bit 0: Validation input function = 1 bit 1: Validation output function = 1 bit 2: Strategy of fallback: 1 = get value, 0 = stay at current value bit 3: Input filtering (1 = fast, 0 = normal), fixed at 0 bit 4: Ouput protection (1 = yes, 0 = no) bit 5: Rearm outputs: 1 = automatic, 0 = by command bit 6: Not used bit 7: Power supply control inhibition (1 = yes, 0 = 0)								
			Fallback value (ouputs) or sensor type (inputs) for channel:							
		bit 8	0	8	16	24	32	40	48	56
		bit 9	1	9	17	25	33	41	49	57
		bit 10	2	10	18	26	34	42	50	58
		bit 11	3	11	19	27	35	43	51	59
		bit 12	4	12	20	28	36	44	52	60
		bit 13	5	13	21	29	37	45	53	61
		bit 14	6	14	22	30	38	46	54	62
		bit 15	7	15	23	31	39	47	55	63
%KW.r.m.c.1	INT									
byte 0	byte		Validation of Input/output open line control for channel:							
		bit 0	0	8	16	24	32	40	48	56

Object	Type	Detail	Channel group							
		bit 1	1	9	17	25	33	41	49	57
		bit 2	2	10	18	26	34	42	50	58
		bit 3	3	11	19	27	35	43	51	59
		bit 4	4	12	20	28	36	44	52	60
		bit 5	5	13	21	29	37	45	53	61
		bit 6	6	14	22	30	38	46	54	62
		bit 7	7	15	23	31	39	31	55	63
byte 1	byte		Validation of value memorization for channel:							
		bit 8	0	8	16	24	32	40	48	56
		bit 9	1	9	17	25	33	41	49	57
		bit 10	2	10	18	26	34	42	50	58
		bit 11	3	11	19	27	35	43	51	59
		bit 12	4	12	20	28	36	44	52	60
		bit 13	5	13	21	29	37	45	53	61
		bit 14	6	14	22	30	38	46	54	62
		bit 15	7	15	23	31	39	47	55	63
%KWr.m.c.2	INT									
byte 0	byte	not used								
byte 1	byte	not used								

There are one %KWr.m.c.0, one %KWr.m.c.1 and one %KWr.m.c.2 common for all channels for a group in this FB_type

NOTE: It is not possible to configure a module by programming using direct language objects %KW; these words are accessible in read only format.

Discrete Device DDT Names

Introduction

This topic describes the Control Expert **Discrete Device DDT**. The instance default naming is described in Device DDT Instance Naming Rule (see EcoStruxure™ Control Expert, Program Languages and Structure, Reference Manual).

Regarding the device DDT, its name contains the following information:

- platform with:

- U for unified structure between Modicon X80 module and Quantum
- device type (DIS for discrete)
- function (STD for standard)
- direction:
 - IN
 - OUT
- max channel (1, 2, 4 ...64)

Example

For a Modicon X80 module with 16 standard inputs/outputs: T_U_DIS_STD_IN_16_OUT_16

List of Implicit Device DDT

The following table shows the list of device DDT and their X80 modules:

Device DDT Type	Modicon X80 Devices
T_U_DIS_STD_IN_8	BMX DAI 0805 BMX DAI 0814
T_U_DIS_STD_IN_16	BMX DAI 1602 BMX DAI 1603 BMX DAI 1604 BMX DAI 1614 BMX DAI 1615 BMX DDI 1602 BMX DDI 1603 BMX DDI 1604
T_U_DIS_STD_IN_32	BMX DDI 3202K BMX DDI 3203 BMX DDI 3232
T_U_DIS_STD_IN_64	BMX DDI 6404K
T_U_DIS_STD_OUT_8	BMX DRA 0804 BMX DRA 0805 BMX DRA 0815 BMX DRC 0805

Device DDT Type	Modicon X80 Devices
T_U_DIS_STD_OUT_16	BMX DDO 1612 BMX DDO 1602 BMX DAO 1605 BMX DAO 1615 BMX DRA 1605
T_U_DIS_STD_OUT_32	BMX DDO 3202K
T_U_DIS_STD_OUT_64	BMX DDO 6404K
T_U_DIS_STD_IN_8_OUT_8	BMX DDM 16022 BMX DDM 16025
T_U_DIS_STD_IN_16_OUT_16	BMX DDM 3202K

Implicit Device DDT Description

The following table shows the T_U_DIS_STD_IN_x and the T_U_DIS_STD_OUT_y status word bits:

Standard Symbol	Type	Meaning	Access
MOD_HEALTH	BOOL	0 = the module has a detected error	read
		1 = the module is operating correctly	
MOD_FLT ¹	BYTE	internal detected errors byte, page 370 of the module	read
DIS_CH_IN	ARRAY [0...x-1] of T_U_DIS_STD_CH_IN	array of structure	
DIS_CH_OUT	ARRAY [0...y-1] of T_U_DIS_STD_CH_OUT	array of structure	
1 Module Status is implicitly exchanged through the MOD_FLT field			

The following table shows the T_U_DIS_STD_IN_x_OUT_y status word bits:

Standard Symbol	Type	Meaning	Access
MOD_HEALTH	BOOL	0 = the module has a detected error	read
		1 = the module is operating correctly	
MOD_FLT ¹	BYTE	internal detected errors byte, page 370 of the module	read

Standard Symbol	Type	Meaning	Access
DIS_CH_IN	ARRAY [0...x-1] of T_U_DIS_STD_CH_IN	array of structure	
DIS_CH_OUT	ARRAY [x...(x+y-1)] of T_U_DIS_STD_CH_OUT	array of structure	
1 Module Status is implicitly exchanged through the MOD_FLT field			

The following table shows the T_U_DIS_STD_CH_IN[0...x-1] and the T_U_DIS_STD_CH_OUT[x... (x+y-1)] structure meaning:

Standard Symbol	Type	Meaning	Access
CH_HEALTH	BOOL	0 = the channel has a detected error	read
		1 = the channel is operating correctly	
VALUE	EBOOL	indicates the status of the sensor controlling the input channel c	read ¹
1 VALUE of the T_U_DIS_STD_CH_OUT structure can be accessed in read / write			

Explicit DDT Instances Description

Explicit exchanges (Read Status or Write Command) - only applicable to Modicon X80 I/O channels - are managed with READ_STS_QX or WRITE_CMD_QX EFB instances for Modicon Quantum and by READ_STS_MX or WRITE_CMD_MX EFB instances for Modicon M580.

- Targeted channel address (ADDR) can be managed with ADDMX EF (connect ADDMX OUT to ADDR)
- READ_STS_QX or READ_STS_MX output parameter (STS) can be connected to a "T_M_XXX_YYY_CH_STS" DDT instance (variable to be created manually), where:
 - xxx represents the device type
 - yyy represents the function

Example: T_M_DIS_STD_CH_STS

- WRITE_CMD_QX or WRITE_CMD_MX input parameter (CMD) can be connected to a ""T_M_DIS_STD_XXX_YYY_CMD" DDT instance

where:

- xxx represents the device type
- yyy represents the direction

Example: T_M_DIS_STD_CH_IN_CMD

For more details about EF and EFB, refer to *EcoStruxure™ Control Expert, I/O Management, Block Library* and *EcoStruxure™ Control Expert, Communication, Block Library*.

The following table shows the T_M_DIS_STD_CH_STS structure status word bits:

Standard Symbol		Type	Bit	Meaning	Access
CH_FLT	TRIP	BOOL	0	external detected error tripped	read
	FUSE	BOOL	1	external detected error: fuse	read
	BLK	BOOL	2	terminal block detected error	read
	EXT_PS_FLT	BOOL	3	internal detected error: module out of order	read
	INTERNAL_FLT	BOOL	4	external supply detected fault	read
	CONF_FLT	BOOL	5	configuration detected fault: different hardware and software configurations	read
	COM_FLT	BOOL	6	problem communicating with the PLC	read
	–	BOOL	7	reserved	read
	SHORT_CIRCUIT	BOOL	8	external detected error: short-circuit on a channel	read
	LINE_FLT	BOOL	9	Open wire detection ⁽¹⁾	read

(1) Only for BMX DAI 1614 and BMX DAI 1615 modules.

The following table presents the `T_M_DIS_STD_CH_IN_CMD` structure status word bits:

Standard Symbol		Type	Bit	Meaning	Access
CH_CMD [INT]	PS_CTRL_DIS	BOOL	1	disable control of the external supply	read / write
	PS_CTRL_EN	BOOL	2	enable control of the external supply	read / write

The following table presents the `T_M_DIS_STD_CH_OUT_CMD` structure status word bits:

Standard Symbol		Type	Bit	Meaning	Access
CH_CMD [INT]	REAC_OUT	BOOL	0	reactivation of tripped outputs (protected outputs)	read / write
	PS_CTRL_DIS	BOOL	1	disable control of the external supply	read / write
	PS_CTRL_EN	BOOL	2	enable control of the external supply	read / write

NOTE: In a user application the `WRITE_CMD_QX` (in an EIO drop) can also define the active or inactive state of the external power supply monitoring and overrides the **Supply monitoring** setting.

`WRITE_CMD_QX` only works over the first 8 channels (0...7, 16...23, 32...39 and 48...55) of the 16-channel groups, but affects all 16 channels of the group.

MOD_FLT Byte Description

MOD_FLT Byte in Device DDT

MOD_FLT byte structure:

Bit	Symbol	Description
0	MOD_FAIL	<ul style="list-style-type: none"> • 1: Internal detected error or module failure detected. • 0: No detected error
1	CH_FLT	<ul style="list-style-type: none"> • 1: Inoperative channels. • 0: Channels are operative.
2	BLK	<ul style="list-style-type: none"> • 1: Terminal block detected error. • 0: No detected error. <p>NOTE: This bit may not be managed.</p>
3	–	<ul style="list-style-type: none"> • 1: Module in self-test. • 0: Module not in self-test. <p>NOTE: This bit may not be managed.</p>
4	–	Not used.
5	CONF_FLT	<ul style="list-style-type: none"> • 1: Hardware or software configuration detected error. • 0: No detected error.
6	NO_MOD	<ul style="list-style-type: none"> • 1: Module is missing or inoperative. • 0: Module is operating. <p>NOTE: This bit is managed only by modules located in a remote rack with a BME CRA 312 10 adapter module. Modules located in the local rack do not manage this bit that remains at 0.</p>
7	–	Not used.

Debugging

What's in This Chapter

Introduction to the Debugging Function of a Discrete Module.....	371
Debugging Screen	371
How to Access the Forcing/Unforcing Function.....	373
How to Access the SET and RESET Commands	374
How to Access the Reactivation of Outputs Command.....	375
Applied Outputs of a Discrete Module.....	375

Subject of this Section

This section describes the debugging aspect of the application-specific discrete module for implementation.

Introduction to the Debugging Function of a Discrete Module

Introduction

For each discrete input/output module, the Debug function enables:

- display of the parameters of each of its channels (channel state, filtering value, etc.)
- access to the diagnostics and adjustment functions for the selected channel (channel forcing, channel masking, etc.)

The function also gives access to module diagnostics in the event of a detected error.

NOTE: This function is only available in on-line mode.

Debugging Screen

At a Glance

The debugging screen (see EcoStruxure™ Control Expert, Operating Modes) shows, in real time, the value and state of each channel of the selected module. It also allows access to the channel commands (forcing of the input or output value, reactivation of outputs, etc.).

Illustration

The figure below shows a sample debugging screen.

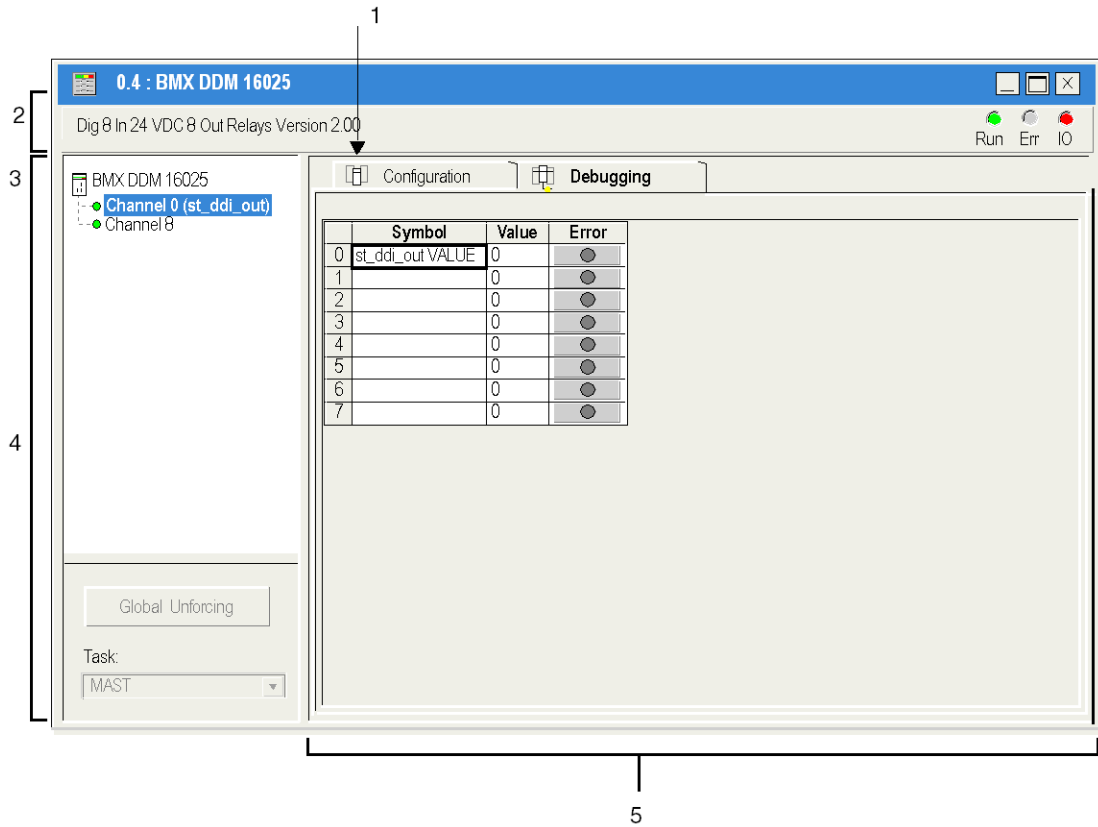

Description

The following table shows the various parts of the debugging screen and their functions.

Number	Element	Function
1	Tabs	The tab in the foreground indicates the mode in progress (Debug in this example). Every mode can be selected using the respective tab. <ul style="list-style-type: none"> • Debug which can be accessed only in online mode • Configuration
2	Module area	Contains the abbreviated title of the module.

Number	Element	Function
		In the same area there are 3 LEDs which indicate the module's operating mode: <ul style="list-style-type: none"> • RUN indicates the operating status of the module • ERR indicates an internal event in the module • I/O indicates an event from outside the module or an application issue
3	Channel area	Allows you: <ul style="list-style-type: none"> • by clicking on the reference number, to display the tabs: <ul style="list-style-type: none"> ◦ Description which gives the characteristics of the device ◦ I/O Objects, (see EcoStruxure™ Control Expert, Operating Modes) which is used to pre-symbolize the input/output objects ◦ Fault which shows the device status (in on-line mode) • to select a channel • to display the Symbol, name of the channel defined by the user (using the variable editor)
4	General parameters area	Specifies the parameters of the channel: <ul style="list-style-type: none"> • Function: specifies the function configured. This heading is frozen. The Global unforcing button provides direct access to the global unforcing of channels function. • Task: specifies the MAST or FAST task configured. This heading is frozen.
5	Parameters in progress field	This field displays the state of inputs and outputs and the various current parameters. For each channel, four items of information are available: <ul style="list-style-type: none"> • Symbol displays the symbol associated with the channel when it has been defined by the user (using the variable editor) • Value displays the state of each channel of the module • Error provides direct access to channel by channel diagnostics when these are inoperable (indicated by the LED built into the diagnostics access, which turns red)

How to Access the Forcing/Unforcing Function

At a Glance

This function allows you to modify the state of all or part of the channels of a module.

NOTE: The state of a forced output is frozen and can only be modified by the application after unforcing. However, in the event of a detected error leading to output fallback, the state of these outputs -assumes the value defined when configuring the **Fallback mode**, page 351 parameter.

The various commands available are:

- for one or more channels:

- force to 1
- force to 0
- unforcing (when the channel or channels selected are forced)
- for all the channels on the module (when at least one channel is forced):
 - global unforcing of channels

Procedure

The following table shows the procedure for forcing or unforcing all or part of the channels of a module.

Step	Action for one channel	Action for all channels
1	Access the module's debugging screen.	
2	In the Value column, right-click the cell of the required channel.	Click on the Global unforcing button found in the general parameters field.
3	Select the required function: <ul style="list-style-type: none"> • forcing to 0 • forcing to 1 	

How to Access the SET and RESET Commands

At a Glance

These commands are used to change the state of a module's outputs to 0 (**RESET**) or 1 (**SET**).

NOTE: The state of the output affected by one of these commands is temporary and can be modified at any time by the application when the PLC is in **RUN**.

Procedure

The table below shows the procedure for assigning the value 0 or 1 to all or part of the channels of a module.

Step	Action for one channel
1	Access the module's debugging screen.
2	In the Value column, right-click the cell of the required channel.
3	Select the desired function. <ul style="list-style-type: none"> • Set • Reset

How to Access the Reactivation of Outputs Command

At a Glance

When an event has caused a tripped output, this command is used to reactivate the output if no error remains at its terminals.

Reset is defined by a group of 8 channels. It has no effect on an inactive channel or channel without a detected error.

Procedure

The following table shows the procedure for reactivating tripped outputs.

Step	Action
1	Access the module's debugging screen.
2	For the chosen group of channels, click on the Reset button situated in the General parameters field.

Applied Outputs of a Discrete Module

At a Glance

This check (red **Stop** LED lit) informs the user that a given group of output channels is not correctly applied by the PLC (fallback status).

The possible causes are:

- processor error
- rack connection error
- inter-rack link connection error

Diagnostics of the Modules

What's in This Chapter

How to Access the Diagnostics Function.....	376
How to Access the Channel Diagnostics Function of a Discrete Module.....	377

Subject of this Section

This section describes the diagnostic aspect in the implementation of the application-specific discrete modules.

How to Access the Diagnostics Function

At a Glance

The **Module diagnostics** function displays current errors and where they exist. Errors are classified according to their category.

- **Internal events:**
 - module inoperable
 - self-tests running
- **External events**
- **Other events:**
 - configuration error
 - module missing or off
 - inoperative channel(s)

A module status is indicated when certain LED's change to red, such as:

- in the configuration editor at rack level:
 - the LED of the rack number
 - the LED of the slot number of the module on the rack
- in the configuration editor at module level:
 - the **I/O** LED according to the type of event
 - the **Channel** LED in the **Channel** field
 - the **Fault** tab

Procedure

The following table shows the procedure for accessing the **Module status** screen.

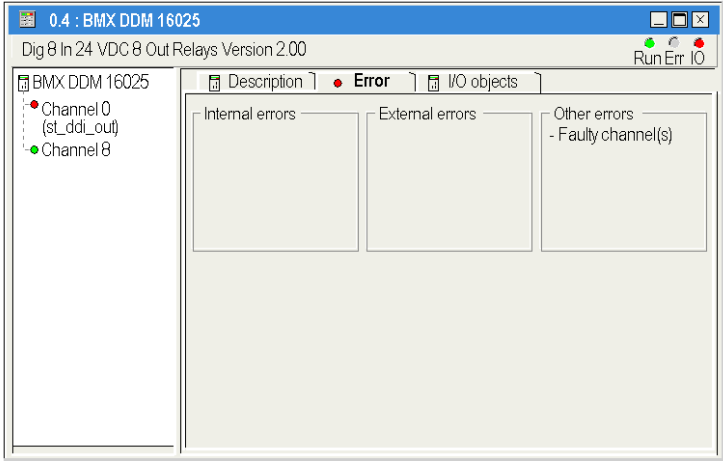
Step	Action
1	Access the module's debugging screen.
2	<p>Click on the module reference in the channel zone and select the Fault command.</p> <p>Result: The list of module errors appears.</p>  <p>Remark: It is not possible to access the module diagnostics screen if a configuration error, major breakdown error, or module missing error occurs. The following message then appears on the screen: The module is not present or is different from the one configured in this position.</p>

How to Access the Channel Diagnostics Function of a Discrete Module

At a Glance

The **Channel diagnostics** function displays current errors and where they exist. Errors are classified according to their category:

- **Internal events:**
 - inoperative channel
- **External events:**

- link or sensor supply fault
- **Other events:**
 - terminal block incorrectly wired
 - configuration error
 - communication interruption

A channel error appears in the **Debug** tab when the  LED, located in the **Error** column, turns red.

Procedure

The following table shows the procedure for accessing the **Channel error** screen.

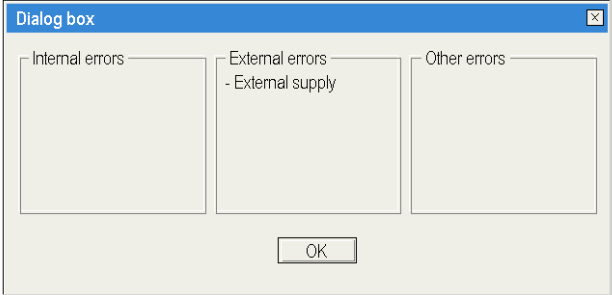
Step	Action
1	Access the module's debugging screen.
2	<p>Click on the button  situated in the Error column of the inoperative channel.</p> <p>Result: The list of channel errors appears.</p> <div data-bbox="337 812 948 1105"></div> <p>Note: Channel diagnostics information can also be accessed by program using the <code>READ_STS</code> instruction.</p>

Appendices

What's in This Part

Topological/State RAM Addressing of the Modules 380

Overview

These appendices contain information that should be useful for programming the application.

Topological/State RAM Addressing of the Modules

What's in This Chapter

Topological/State RAM Addressing of ModiconX80 Discrete Modules 380

Topological/State RAM Addressing of ModiconX80 Discrete Modules

Discrete Modules

With firmware 2.4 or later, you can access the modules either via topological or State RAM addresses. Please also refer to *Memory Tab* (see EcoStruxure™ Control Expert, Operating Modes).

The following table shows the Modicon X80 discrete module objects that can be mapped to topological or State RAM addresses.

Module reference	Topological address	State RAM address
BMX DAI 0805 BMX DAI 0814	%I rack.slot.channel, channel [0,7]	-%IStart address ... %IStart address + 7, one channel per %I or -%IWStart address, one channel per bit of %IW
BMX DAI 1602	%I rack.slot.channel, channel [0,15]	- %IStart address ... %IStart address + 15, one channel per %I or - %IWStart address, one channel per bit of %IW
BMX DAI 1603	%I rack.slot.channel, channel [0,15]	- %IStart address ... %IStart address + 15, one channel per %I or - %IWStart address, one channel per bit of %IW
BMX DAI 1604	%I rack.slot.channel, channel [0,15]	- %IStart address ... %IStart address + 15, one channel per %I or - %IWStart address, one channel per bit of %IW

Module reference	Topological address	State RAM address
BMX DAI 0804	%I rack.slot.channel, channel [0,7]	- %IStart address ... %IStart address + 7, one channel per %I or - %IWStart address, one channel per bit of %IW
BMX DAI 1614 BMX DAI 1615	%I rack.slot.channel, channel [0,15]	- %IStart address ... %IStart address + 15, one channel per %I or - %IWStart address, one channel per bit of %IW
BMX DAO 1605	%Q rack.slot.channel, channel [0,15]	- %MStart address ... %MStart address + 15, one channel per %M or - %MWStart address, one channel per bit of %MW
BMX DAO 1615	%Q rack.slot.channel, channel [0,15]	- %MStart address ... %MStart address + 15, one channel per %M or - %MWStart address, one channel per bit of %MW
BMX DAO 0805	%Q rack.slot.channel, channel [0,7]	- %MStart address ... %MStart address + 7, one channel per %M or - %MWStart address, one channel per bit of %MW
BMX DDI 1602	%I rack.slot.channel, channel [0,15]	- %IStart address ... %IStart address + 15, one channel per %I or - %IWStart address, one channel per bit of %IW
BMX DDI 1603	%I rack.slot.channel, channel [0,15]	- %IStart address ... %IStart address + 15, one channel per %I or - %IWStart address, one channel per bit of %IW
BMX DDI 1604	%I rack.slot.channel, channel [0,15]	- %IStart address ... %IStart address + 15, one channel per %I or - %IWStart address, one channel per bit of %IW
BMX DDI 0804	%I rack.slot.channel, channel [0,7]	- %IStart address ... %IStart address + 7, one channel per %I

Module reference	Topological address	State RAM address
		or - %IWStart address, one channel per bit of %IW
BMX DDI 3202K	%I rack.slot.channel, channel [0,31]	- %IStart address ... %IStart address + 31, one channel per %I or - %IWStart address ... %IWStart address + 1, one channel per bit of %IW
BMX DDI 3203	%I rack.slot.channel, channel [0,31]	- %IStart address ... %IStart address + 31, one channel per %I or - %IWStart address ... %IWStart address + 1, one channel per bit of %IW
BMX DDI 3232	%I rack.slot.channel, channel [0,31]	- %IStart address ... %IStart address + 31, one channel per %I or - %IWStart address ... %IWStart address + 1, one channel per bit of %IW
BMX DDI 6402K	%I rack.slot.channel, channel [0,63]	- %IStart address ... %IStart address + 63, one channel per %I or - %IWStart address ... %IWStart address + 3, one channel per bit of %IW
BMX DDM 16022	%I rack.slot.channel, channel [0,7] %Q rack.slot.channel, channel [16,23]	- %IStart address ... %IStart address + 7, one channel per %I and - %M Start address ... %MStart address + 7, one channel per %M or - %IWStart address, one channel per bit of %IW and %MWStart address, one channel per bit of %MW
BMX DDM 16025	%I rack.slot.channel, channel [0,7] %Q rack.slot.channel, channel [16,23]	- %IStart address ... %IStart address + 7, one channel per %I and

Module reference	Topological address	State RAM address
		- %M Start address ... %MStart address + 7, one channel per %M or - %IWStart address one channel per bit of %IW and - %MWStart address, one channel per bit of %MW
BMX DDM 3202K	%I rack.slot.channel, channel [0,15] %Q rack.slot.channel, channel [16,31]	- %IStart address ... %IStart address + 15, one channel per %I and - %M Start address ... %MStart address + 15, one channel per %M or - %IWStart address, one channel per bit of %IW and - %MWStart address, one channel per bit of %MW
BMX DDO 1602	%Q rack.slot.channel, channel [0,15]	- %MStart address ... %MStart address + 15, one channel per %M or - %MWStart address, one channel per bit of %MW
BMX DDO 1612	%Q rack.slot.channel, channel [0,15]	- %MStart address ... %MStart address + 15, one channel per %M or - %MWStart address, one channel per bit of %MW
BMX DDO 3202K	%Q rack.slot.channel, channel [0,31]	- %MStart address ... %MStart address + 31, one channel per %M or - %MWStart address ... %MWStart address + 1, one channel per bit of %MW
BMX DDO 6402K	%Q rack.slot.channel, channel [0,63]	- %MStart address ... %MStart address + 63, one channel per %M or - %MWStart address ... %MWStart address + 3, one channel per bit of %MW
BMX DRA 0804	%Q rack.slot.channel, channel [0,7]	- %MStart address ... %MStart address + 7, one channel per %M or

Module reference	Topological address	State RAM address
		- %MWStart address, one channel per bit of %MW
BMX DRA 0805	%Q rack.slot.channel, channel [0,7]	- %MStart address ... %MStart address + 7, one channel per %M or - %MWStart address, one channel per bit of %MW
BMX DRA 0815	%Q rack.slot.channel, channel [0,7]	- %MStart address ... %MStart address + 7, one channel per %M or - %MWStart address, one channel per bit of %MW
BMX DRC 0805	%Q rack.slot.channel, channel [0,7]	- %MStart address ... %MStart address + 7, one channel per %M or - %MWStart address, one channel per bit of %MW
BMX DRA 1605	%Q rack.slot.channel, channel [0,15]	- %MStart address ... %MStart address + 15, one channel per %M or - %MWStart address, one channel per bit of %MW

For additional information please refer to *Special Conversion for Compact I/O Modules* (see EcoStruxure™ Control Expert, Concept Application Converter, User Manual).

Glossary

D

DDT:

(*derived data type*) A set of elements with the same type (`array`) or with different types (`structure`).

Index

20-pin terminal blocks installing.....	57
40-pin terminal blocks installing.....	62

A

ABE-7H08R10.....	313
ABE-7H08R11.....	313
ABE-7H08R21.....	316
ABE-7H08S21.....	320
ABE-7H12R10.....	314
ABE-7H12R11.....	314
ABE-7H12R20.....	318
ABE-7H12R21.....	318
ABE-7H12R50.....	326
ABE-7H12S21.....	322
ABE-7H16F43.....	329
ABE-7H16R10.....	313
ABE-7H16R11.....	313
ABE-7H16R20.....	316
ABE-7H16R21.....	316
ABE-7H16R23.....	316
ABE-7H16R30.....	324
ABE-7H16R31.....	324
ABE-7H16R50.....	327
ABE-7H16S21.....	320
ABE-7H16S43.....	330
ABR-7xxx relays.....	336
ABS-7Exx relays.....	337
applied outputs.....	375

B

BMWFTB2020.....	40
BMWFTB4020.....	43
BMWFTB4020H.....	43
BMX FTW ••1 connection cables.....	51
BMX FTW ••5 connection cables.....	55
BMXDAI0805.....	177
BMXDAI0805H.....	177
BMXDAI0814.....	183
BMXDAI1602.....	139
BMXDAI1602H.....	139

BMXDAI1603.....	147
BMXDAI1603H.....	147
BMXDAI1604.....	153
BMXDAI1604H.....	153
BMXDAI1614.....	159
BMXDAI16142.....	159
BMXDAI1614H.....	159
BMXDAI1615.....	169
BMXDAI1615H.....	169
BMXDAO1605.....	257
BMXDAO1605H.....	257
BMXDAO1615.....	263
BMXDAO1615H.....	263
BMXDDI1602.....	102
BMXDDI1602H.....	102
BMXDDI1603.....	109
BMXDDI1603H.....	109
BMXDDI1604T.....	116
BMXDDI3202K.....	188
BMXDDI3202KH.....	188
BMXDDI3203.....	124
BMXDDI3203H.....	124
BMXDDI3232.....	131
BMXDDI3232H.....	131
BMXDDI6402K.....	195
BMXDDI6402KH.....	195
BMXDDM16022.....	271
BMXDDM16022H.....	271
BMXDDM16025.....	281
BMXDDM16025H.....	281
BMXDDM3202K.....	290
BMXDDO1602.....	202
BMXDDO1602H.....	202
BMXDDO1612.....	208
BMXDDO1612H.....	208
BMXDDO3202K.....	245
BMXDDO3202KC.....	245
BMXDDO6402K.....	251
BMXDDO6402KC.....	251
BMXDRA0804T.....	214
BMXDRA0805.....	219
BMXDRA0805H.....	219
BMXDRA0815.....	225
BMXDRA0815H.....	225
BMXDRA1605.....	232
BMXDRA1605H.....	232
BMXDRC0805.....	238
BMXDRC0805H.....	238

BMXFCC051 82
 BMXFCC053 82
 BMXFCC1001 82
 BMXFCC1003 82
 BMXFCC101 82
 BMXFCC103 82
 BMXFCC201 82
 BMXFCC203 82
 BMXFCC301 82
 BMXFCC303 82
 BMXFCC501 82
 BMXFCC503 82
 BMXFCW1001 76
 BMXFCW1003 76
 BMXFCW301 76
 BMXFCW303 76
 BMXFCW501 76
 BMXFCW503 76
 BMXFTB2000 40
 BMXFTB2010 40
 BMXFTB4000 43
 BMXFTB4000H 43
 BMXFTW1001 49
 BMXFTW301 49
 BMXFTW305 53
 BMXFTW501 49
 BMXFTW505 53

C

certifications 36
 channel data structure for all modules
 T_DIS_IN_GEN 356
 T_DIS_IN_STD 357–358
 T_DIS_OUT_GEN 359
 T_DIS_OUT_STD 360–361
 T_GEN_MOD 362
 connection bases 298
 connection cables 76, 82

D

debugging 371
 diagnostics 376–377

F

fallback mode 351
 FCN connector
 installing 76, 82
 FCN type connector
 installing 67
 forcing 373

I

input parameters 347

M

MOD_FLT 370

O

output parameters 348
 output reset 352

P

parameter settings 354

R

reactivation of outputs 375
 relays 332, 338
 RESET 374

S

SET 374
 simulator 340
 standards 36
 state RAM/topological addressing of X80
 discrete modules 380

T

task parameter 350
 T_DIS_IN_GEN 356

T_DIS_IN_STD.....	357–358
T_DIS_OUT_GEN	359
T_DIS_OUT_STD.....	360–361
temperature derating	34
terminal blocks	
installing.....	37
T_GEN_MOD	362
topological/state RAM addressing of X80	
discrete modules	380
T_U_DIS_STD_IN_16.....	365
T_U_DIS_STD_IN_16_OUT_16	365
T_U_DIS_STD_IN_32.....	365
T_U_DIS_STD_IN_64.....	365
T_U_DIS_STD_IN_8.....	365
T_U_DIS_STD_IN_8_OUT_8.....	365
T_U_DIS_STD_OUT_16.....	365
T_U_DIS_STD_OUT_32.....	365
T_U_DIS_STD_OUT_64.....	365
T_U_DIS_STD_OUT_8.....	365
TELEFAST 2	298

W

wiring precautions	72
--------------------------	----

Schneider Electric
35 rue Joseph Monier
92500 Rueil Malmaison
France

+ 33 (0) 1 41 29 70 00

www.se.com

As standards, specifications, and design change from time to time, please ask for confirmation of the information given in this publication.

© 2020 – Schneider Electric. All rights reserved.

35012474.18