

# VS - ECH

## ELECTRIC CHAIN HOIST

OPERATING & MAINTENANCE MANUAL



VESTIL MANUFACTURING CORP.  
[WWW.VESTIL.COM](http://WWW.VESTIL.COM)

---

# Contents

<b>1. How to use</b>	
1-1. Conditions	3
1-2. Model (Type)	3
<b>2. How to treat</b>	
2-1. Checking points before installation	3
2-2. Chain bucket	3
2-3. Wiring	4
2-4. Warning points after installation	4
2-5. Warning points in use	5
<b>3. Maintenance and Inspection</b>	
3-1. Inspection before use (Daily inspection)	6
3-2. Periodical inspection (Monthly, Yearly)	7
3-3. Checking points of hoist	7
3-4. Checking points of trolley	8
3-5. Test points after periodical inspection	8
3-6. Checking points of refueling and lubrication	8
3-7. Inspection of hook and load chain	9
3-8. First-aid	9
<b>4. How to connect trolley</b>	
4-1. How to connect trolley and VS-ECH type (Pin type)	10
4-2. How to connect trolley and VS-ECH type (HOOK type)	10
4-3. How to install trolley on the runway beam	10
4-4. How to connect electric power source	11
<b>5. Drawing</b>	
5-1. MN type (HOOK SUSPENSION type)	13
5-2. MNP-H type (MONO-RAIL : HOOK type)	14
5-3. MNP-P type (MONO-RAIL : PIN type)	15
<b>6. Circuit diagram</b>	
6-1. MN-250, 250kg (TBAH05D : STANDARD type)	16
6-2. MNV-250, 250kg (TBAH05D : VARIABLE SPEED SPEED)	17
<b>7. Part list</b>	18
<b>8. Exploded View</b>	40

## 1. How to use MN type

### 1-1 Conditions

Periodical inspection and maintenance of a hoist after installation can help you use the hoist for long time without any problems. But unreasonable use of the hoist regardless to conditions can cause its breakdown.



**Please read the manual before using the hoist surely.**

### 1-2 Model(Type) - Standard specification

#### HOOK SUSPENSION TYPE

- VC-ECH-10-1PH

## 2. How to treat VC-ECH

### 2-1 Checking points before installation

1. Type
2. Capacity
3. Lift
4. Power source
5. Push button switch's length
6. Chain bucket's size
7. When placing order for special type, please purchase after checking the requirement
8. When using trolley, please check a kinds of beam ("I-beam" or "H-beam")

☞ Please refer to page 10,11, 12 about how to connect trolley

### 2-2 Chain bucket

\* Please use the standard chain bucket surely.

It is caused by breaking and deformation of load chain.(Fig. 2)

\* Please refer to Fig. 1 about how to install chain bucket.

(FIG.1)

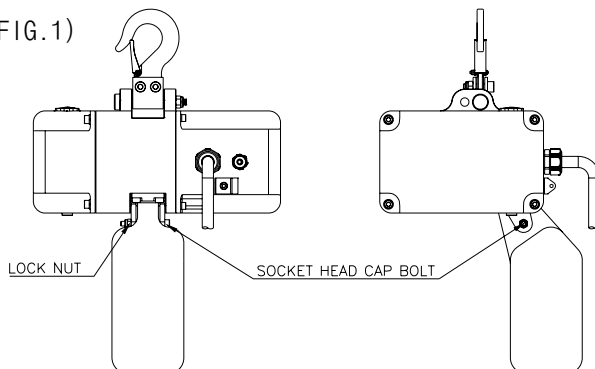

(FIG.2)

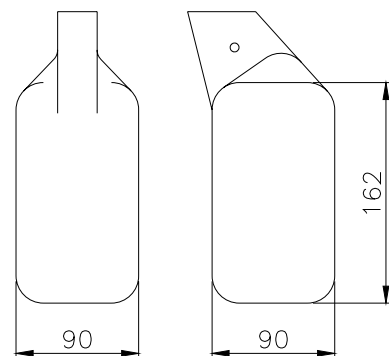

**N.B)** 1. Chain bucket is made of plastic or vinyl.

## 2-3 Wiring

1. Cable for power source consists of VCTFK 0.75mm<sup>2</sup> and Plug.
2. In case of such a long distance between hoist and power source, it can be caused no lifting, motor and driver burnt by sudden drop of power.
3. Cable for control is VCT KEVV-HR 0.5mm<sup>2</sup> x 8C and Max. length is by 10m.  
When over 10m, it can be made error of driver.



**If there is much distance between hoist and power, use the bigger power cable than standard requirements as there may be a drop of electric pressure (Rapid drops or overheating of hoist motor, cable and driver and etc.)**

## 2-4 Warning points after installation

1. Please apply oil on the load chain surely which will lengthen the life span of load chain and prevent troubles (Fig. 3). Also, keep load chain clean all the time or it will cause load chain breaking.



**Please do not use grease absolutely.**

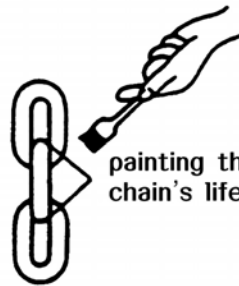

(FIG.3)

2. Please assemble the hoist in the way the welding part of the load chain faces the outside lest that part should rub against the load sheave like (Fig. 4). Even When maintenance and exchange of load chain.

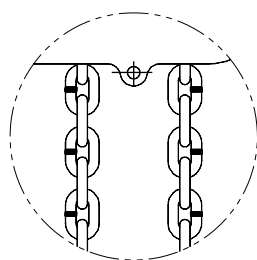

Welding point : outside  
< OK! >

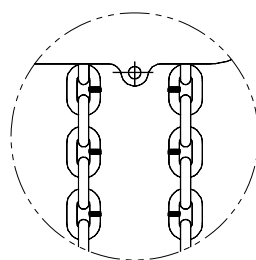

Welding point : inside  
< NO! >

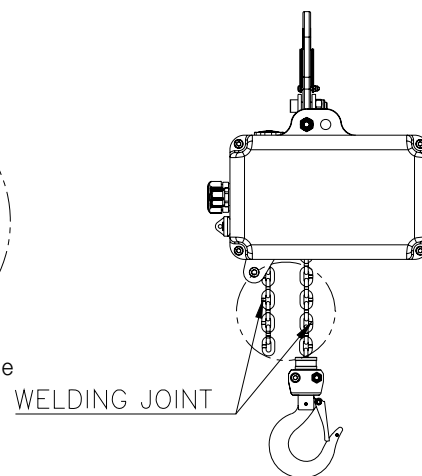

(FIG.4)

---

## 2-5. Warning points in use

### 1. Checking points before operating a hoist surely

**⚠ Please do not make a deformation of load chain on purpose**

- (1) Is oil applied on the load chain?
- (2) Does it work downward though you press "UP" of push button?
- (3) Does the push button work smoothly?
- (4) Does the role of limit switch work at the stat of unload?
- (5) Does the brake work well without slips? (page 7, Table-1)
- (6) Does a trolley work well without any interference on the monorail beam?

### 2. Checking points in use

**⚠ ※Please observe the followings for safety.**

- (1) Don't convert a hoist into a lifter or an elevator for cargo.
- (2) Don't use a hoist to lift up goods slantingly. (Fig. 5)  
(If do so, it will cause troubles to a hoist)
- (3) Goods should not exceed the rated load and don't allow anyone to go under loaded goods when a hoist is working. (Fig. 6)

- (4) Never drag the push button cable to move a trolley when you want to connect trolley.
- (5) At normal use, don't use limit switch and slip clutch system. It is a way to prevent breakdown of a hoist.
- (6) Press the push button switch securely and thoroughly. (Fig. 7)
- (7) Put up goods normally to hook block and never use the hoist abnormally. (Fig. 8)
- (8) Don't use the hoist when the load chains are entangled. (Fig. 9)
- (9) Don't do any sudden plugging or continual inching operation.

### 3. Checking points after using a hoist

- (1) Turn off the power switch and plug off surely after using the hoist.
- (2) Don't stop operating the hoist while it's loaded.

**⚠ Be sure to cover a hoist lest rain or water should leak in the hoist when it is installed outside.**

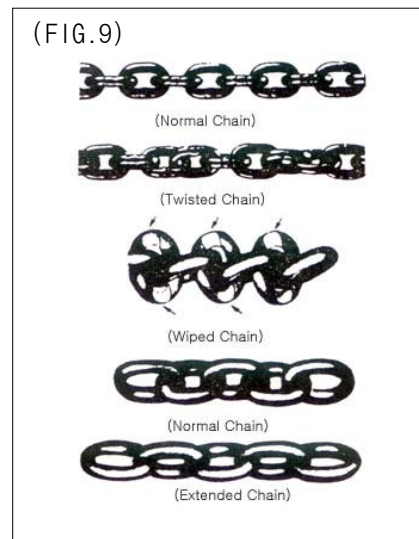
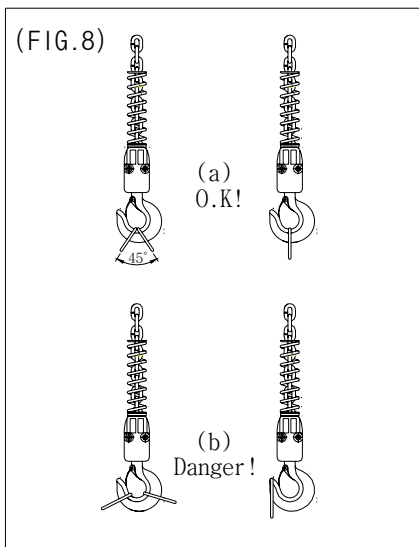
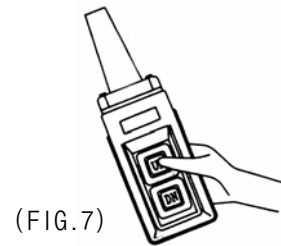
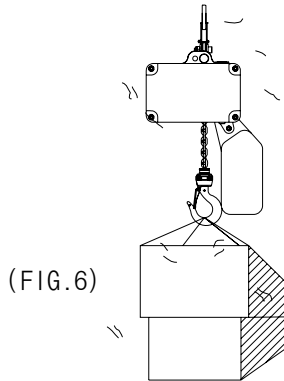
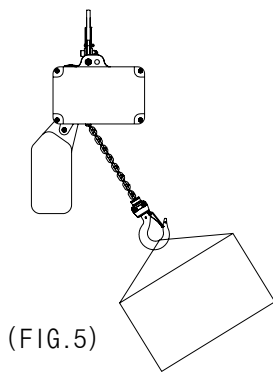

### 3. Maintenance and Inspection

It is very important to check out the hoist daily, monthly and yearly to maintain its long lifespan and be sure to observe the followings for security when one checks out the hoist.

1. Turn off power switch and control power switches with associates.
2. Set the sign of "Repairing" or "Checking" on the hoist while it is under repair.

**⚠ Never check out the hoist while it is loaded.**

#### 3-1. Inspection before use (daily inspection)

1. Checking points before operating a hoist surely
  - (1) Is oil applied on the load chain?
  - (2) Are the load chain entangled?
  - (3) Is safety latch of hook attached normally?
  - (4) Does slip clutch system work normally at the state of unload?
  - (5) Does mechanical brake work normally without slip?
  - (6) Does the trolley work normally?
  - (7) Is the weight of goods loaded on a hoist reasonable?
  - (8) Is it sure that there is no one under loaded goods?

### 3-2. Periodical inspection (Monthly, Yearly)

Since parts and components of the hoist will wear away and will not work well after lone use, inspect the hoist periodically according to checking points for secure working.

1. Monthly inspection (once a month in the presence of a manager)
2. Yearly inspection (once a year in the presence of a manager and engineer)

### 3-3. Checking points of hoist

(Table-1)

Part	Checking points	Inspection	Day	Periodical
Main body	External view	No damage, crack and deformation	☉	☉
	Abnormal sound	No noises from the motor and the gear	☉	☉
	Gear case	No abrasion such as rust, damage and breakdown		☉
	Reduction gear section	No deformation and breakdown of gear		☉
		No abrasion deformation of bearing		☉
Load sheave	No hard abrasion, damages and deformation		☉	
Load chain	Rust & Cracks	No rust(erosion), cracks(flaws) and few abrasion	☉	☉
	Dimensions	Diameter and pitch should be fit to the standard	☉	☉
	Oiling	Coated with oil properly	☉	☉
Top & bottom hook	Opening	Not get wider than the standards dimension		☉
	Holder	No harmful damages, deformation and not opening		☉
	Bottom swivel hook	No problems with bearing		☉
	Bolts & nuts	No abrasion and curved.		☉
Limit switch system	Slip clutch	Proper function of the slip clutch Proper function under unload	☉	☉
Mechanical brake	Slipping	Within 10mm when you operate hoist 2~3 times with rated load	☉	☉
Electric components	Power source cable	No breakage and damages of the rubber covered cables. No disconnection		☉
	Push button switch	Effective connection and proper functioning	☉	☉
	Motor	No overheating and humming		☉
Others	Joint parts	Bolts, nuts, springs, washers, pins and etc. should be assembled normally		☉
	Nameplate	Features and specification of hoist should be attached.		☉
	Chain bucket	Assembled parts should be fixed firmly with bolts.		☉
Good conditions and no foreign object in it.			☉	
Lamp	Green	When power turns on		☉
	Red	When wrong wiring, error, overload and any errors		☉

### 3-4 Checking points of trolley

(Table-2)

Part	Checking points	Inspection	Day	Periodical
Plain trolley	Side plates	No bending and damages		⊙
	Joints parts	No looseness breakage and missing and no breaking away from the right place		⊙
	Wheel (Roller)	No abrasion of wheel (Roller) and gear		⊙
		Rotate smoothly	⊙	⊙
		Well lubricated gears		⊙
	Bearing	Proper engagement with shaft and rotate smoothly		⊙
	Name plate	Exact specifications should be written		⊙
Geared trolley	Hand wheel	No excessive wear in the ratcheted section and pocket sections to engage with hand chain.		⊙
	Name plate	Exact specifications should be written		⊙
	Pinion shaft	Well lubricates for smooth rotation		⊙
	Hand chain	No excessive elongation and deformation that cause smooth engagement with the hand wheel pockets		⊙

### 3-5 Test points after periodical inspection

(Table-3)

Checking points	Inspection
Unloading test	Does the hoist work as the signs of push button indication?
Limit switch test	Does that hoist work normally at that state of unload and the rated load?
Rated loading test	When the hoist works up and down and left and right, are there any noises and vibrations and is there any brake slipping?
Overloading test	Are there any problems at test load?

### 3-6 Checking points of refueling and lubrication

(Table-4)

No.	Refueling parts	Kind of oil	Refueling time	Amount	Caution
1	Top hook pin Bottom hook block	Cup grease(SHELL M.M.P #2)	Yearly	Adequate	
2	Gear section	MACHINE OIL (SHELL MEROPA 220)	Yearly	250CC	Refuel after removing impurity in gear box
3	Load chain	"	Often	Adequate	Oiling on surface of load chain (Not be dried)

Caution) We are using SHELL. In case of using other oil, use same grade like ISO220 grade.



### 3-7. Inspection of hook and load chain

Hook and load chain can be worn away as time goes by by corrode and get wider according to working places and conditions. They are especially important parts for security, so check them based on the Table-5 and Table-6.

Besides, replace them with new ones for secure use when they are more than the using limit dimension.

#### (1) HOOK

(Table-5)

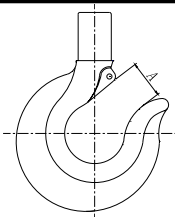
	The rated load (kg)	Normal dimension (A) (mm)	Using limit dimension (A) (mm)
	125 • 250	30	31.5

#### (2) LOAD CHAIN

(Table-6)

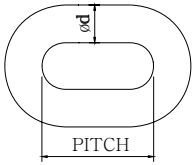
	Model	The rated load (kg)	Diameter Ød (mm)	Normal dimension Pitch (mm)	Using limit dimension 11 links(mm)
	MN TYPE	125 • 250	4.0	12.0	138.6

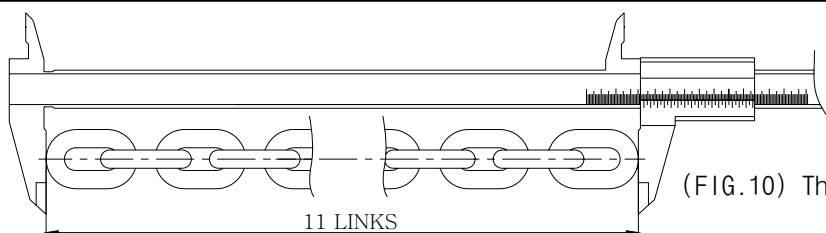

(FIG.10) The measuring way of Load chain

### 3-8 First-aid

(Table-7)

Conditions	Checking points	Troubles	Solutions
When it does not operate initially	Is power supplied certainly?	Push button does not work.	- Press the push button surely. - Connect wire perfectly.
		Motor generated much heat and many noises.	- Replace or repairing
		The running time of motor is so long	- Call to A/S engineer
In case of stop the motor when a hoist is operation	Imperfect connection	When the power wires, the terminal, switches are not connected perfectly.	- Replacement or Checking
	Overload	Motor stop Red lamp on	- Use it within the range of the rated load - Driver reset
Breaking trouble	The poor braking	Mechanical brake is trouble	- Call to A/S engineer
	Load chain keeps running down slowly		

## 4. How to connect trolley

When you connect it to Kuk Dong trolley, you can use it in various ways by connection KD type hoists. Select a model between the following two trolley types.

1. Geared trolley : Model-KGT
2. Plain trolley : Model-KPT

### 4-1. How to connect trolley and MN type hoist (Pin type). (Fig. 11)

1. Disassembling top hook of MN hoist
2. After meet hanger hole of trolley and case hole, removing top hook, the bolt of hook is joined.

### 4-2. How to connect trolley and MN type hoist (Hook type). (Fig. 11)

1. Hang top hook on the hole of trolley.

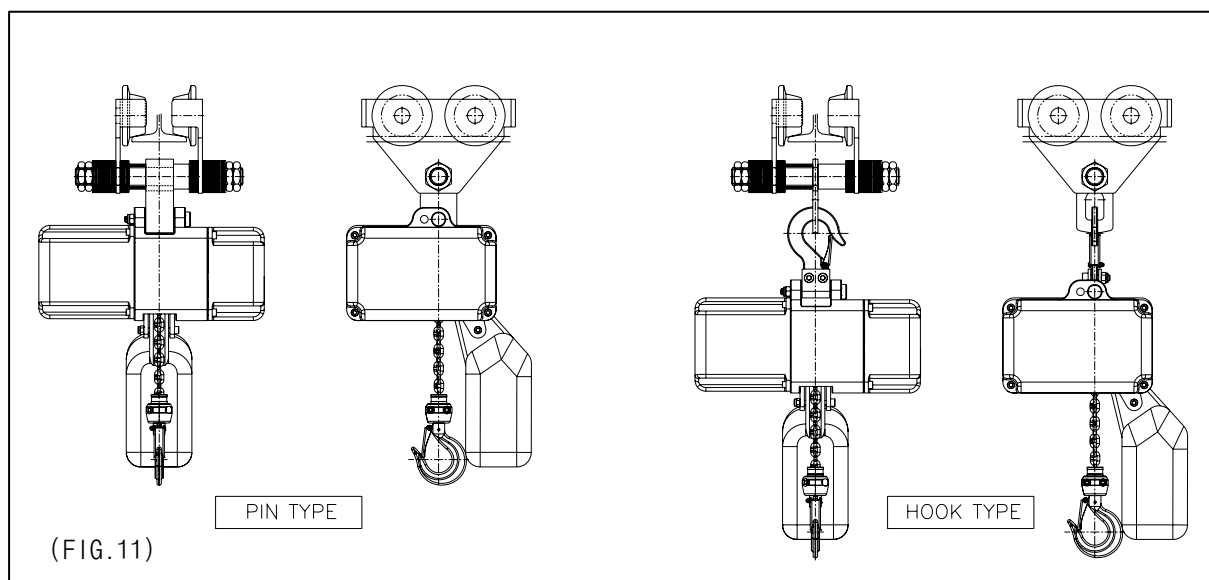

### 4-3. How to install trolley on the runway beam

When you want to install a trolley on I-beam or H-beam type, set them up in the following way.

1. Check the width of the beam for running and trolley  
(Roller wheels of trolley are divided into two ; one is for I-beam and the other is for H-beam)
2. Assembly them by adjusting the adjusting collar on the stay bolts to the inside or the outside of side place.
3. The simplest way is to install a trolley from the end of the runway beam.(Fig. 12)

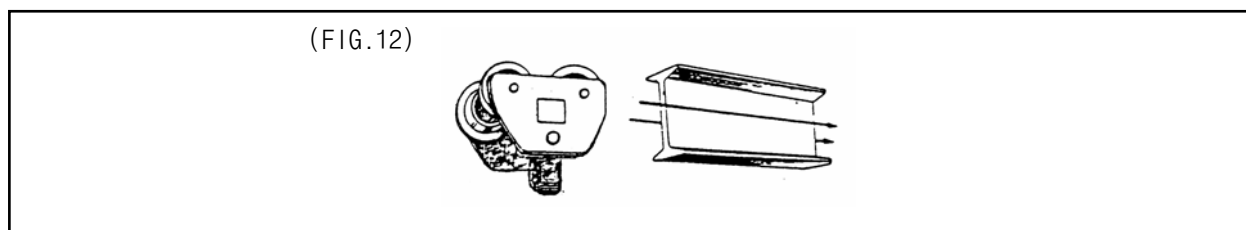

4. If you want to install in the center of beam as another way, after unscrewing stay bolts of the trolley and removing the side plate, put a trolley on one end of a beam and set the other side of the side plate to the stay bolt hole and screw them up. (Fig. 13, 14)

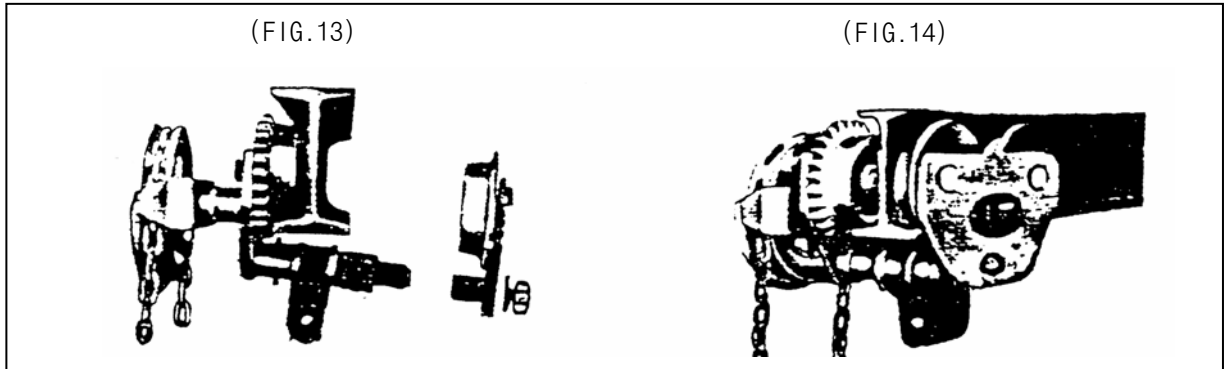

Since the trolley can fall from the runway beam, be sure to attached stoppers to both ends of runway beam. (Fig. 15)

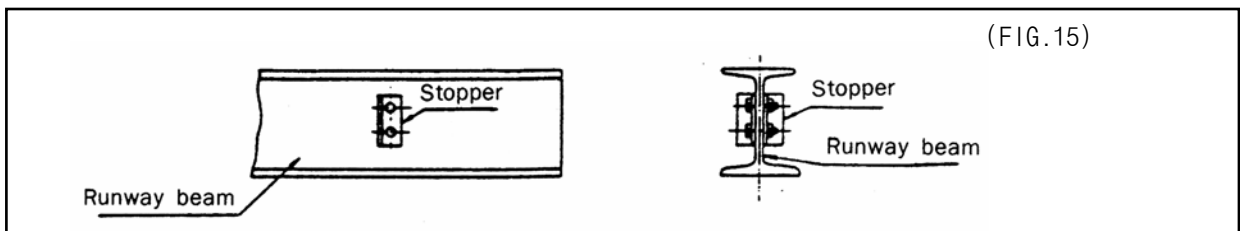

5. When you install a geared trolley on the curved runway beam, hand wheel is positioned on beam outside.

#### 4-4. How to connect electric power source

1. The main power cable should be installed in parallel with the runway beam and the power cable should move together along with a trolley. (Fig. 16)

Install the trolley from the ending part of runway beam.

(FIG. 16)

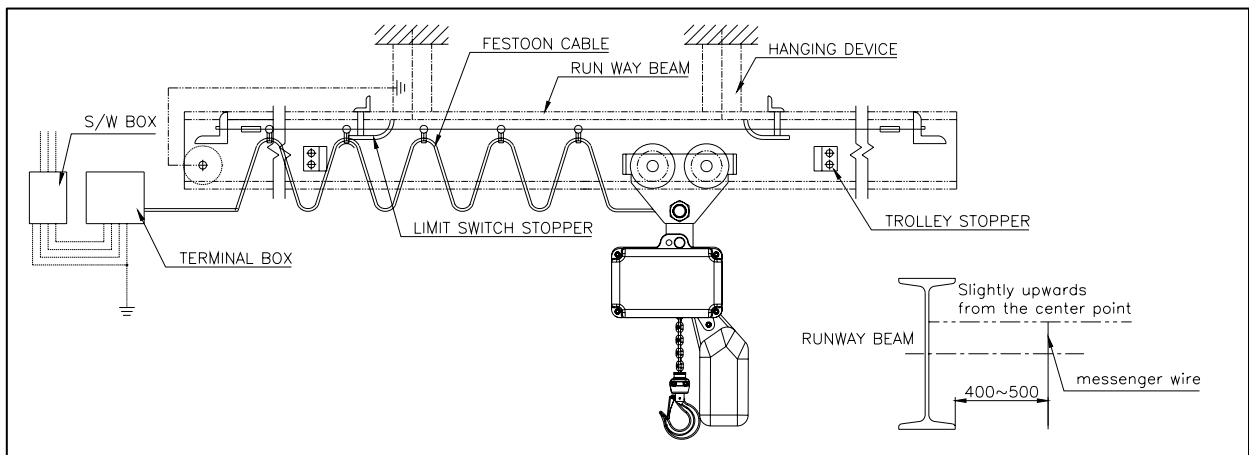

- 
2. The cable wheel should be installed at intervals of 1.5M.
  3. The curved runway beam should be installed in a different way. As an instance, the cable wheel is follow the runway beam.
  4. Since the rotating radius of curved runway beam is different according to the capacity of hoists, consult with agents or distributors about the specifications of right products suited to your working places.

# 5. Drawing

## 5-1. HOOK SUSPENSION type

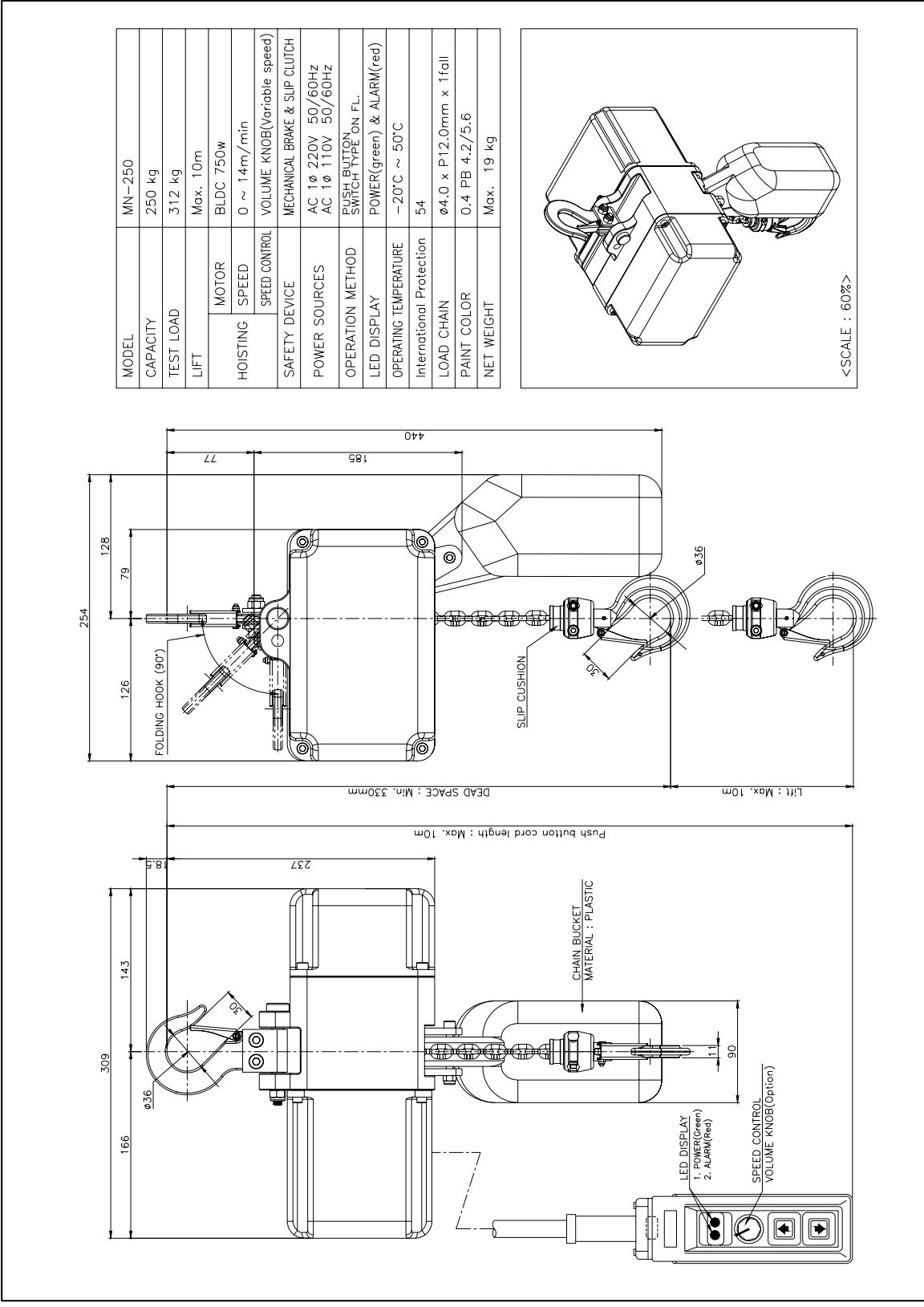

## 6-2. VS-ECH

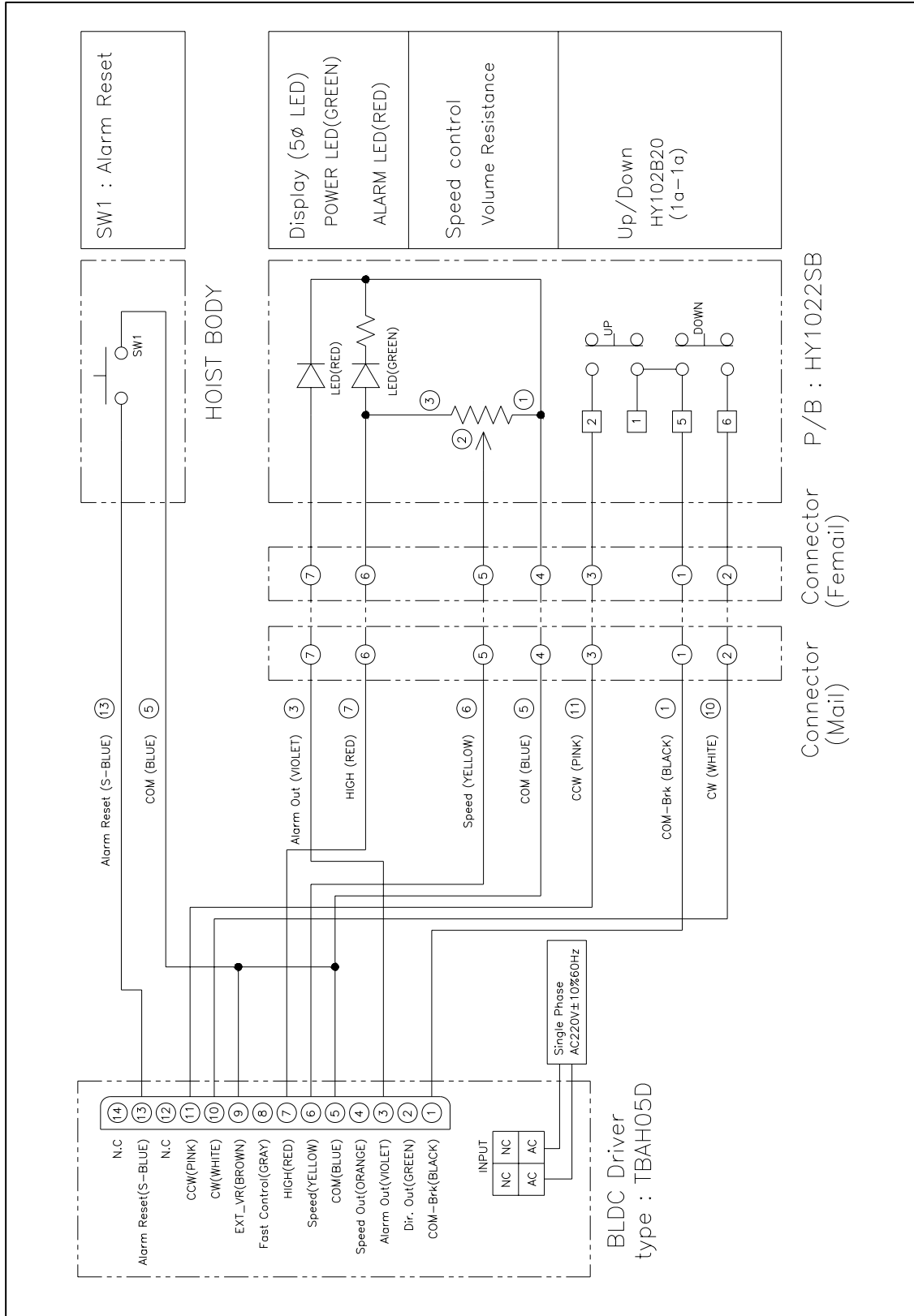

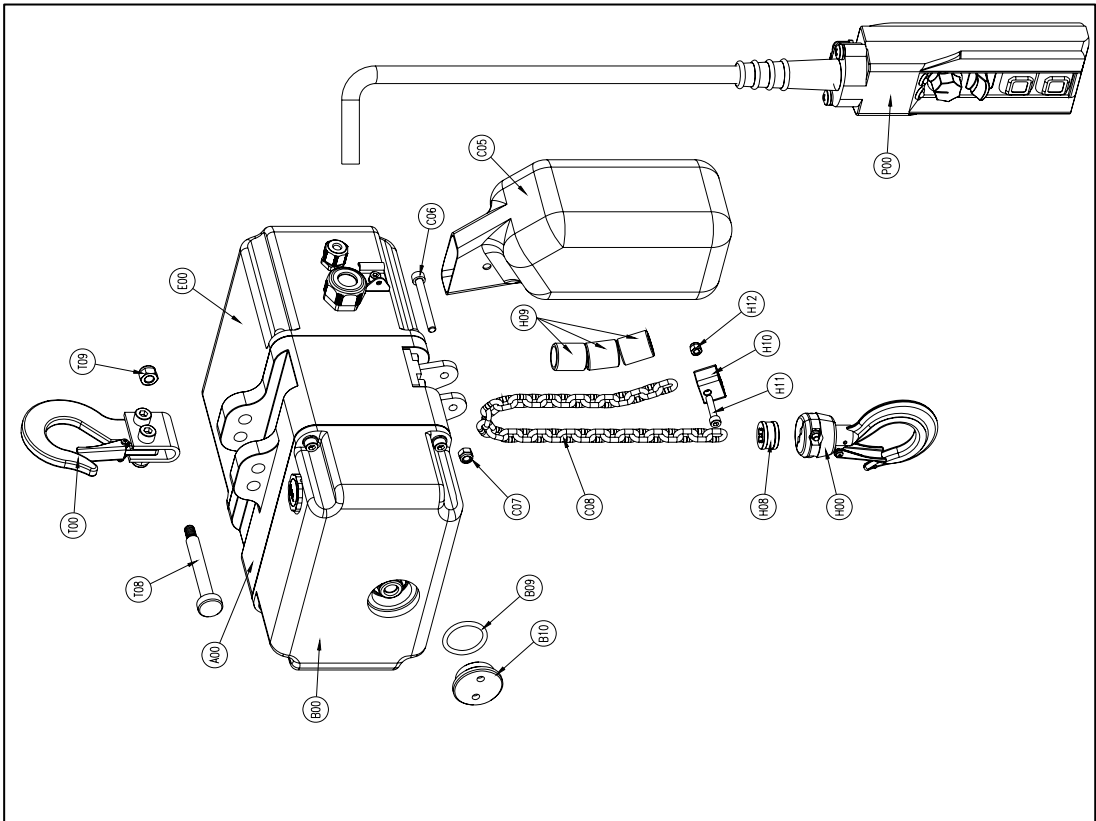
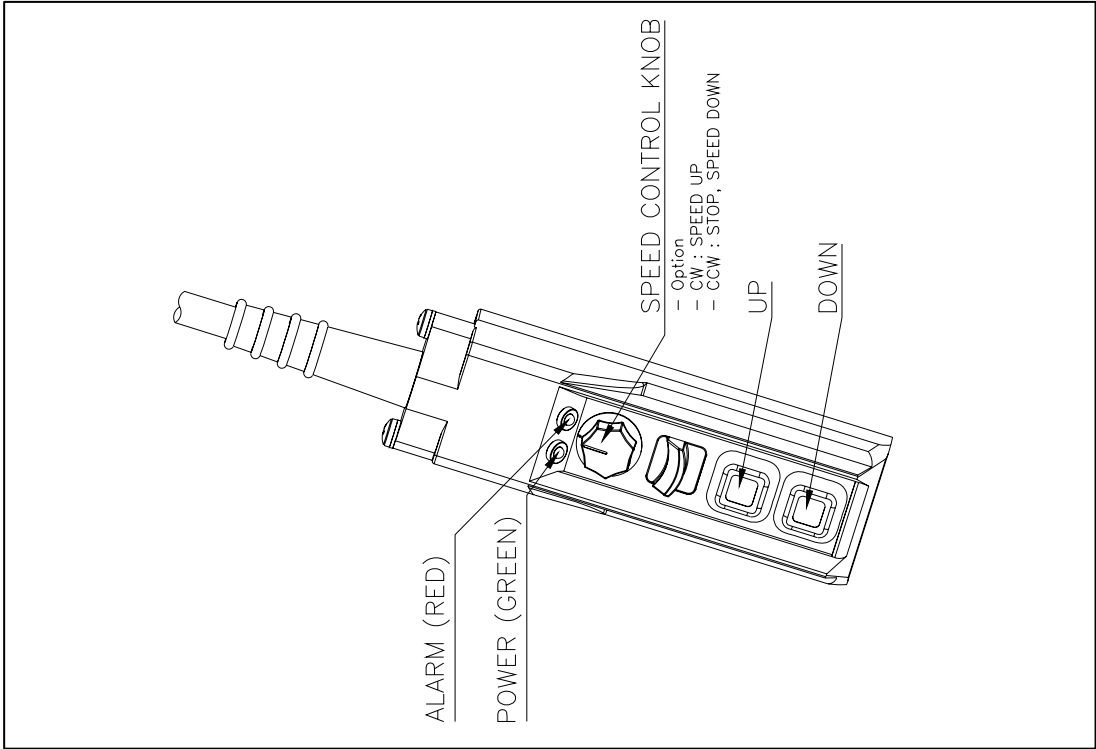

## BODY Assembly

NO	DESCRIPTION	MATERIAL	Q'TY	SIZE	REMARK
A00	MAIN BODY Sub Assy		1	MN-250	
B00	REDUCER CASE Sub Assy		1	MN-250	
B09	O-RING	PUR.	1	P28x3.5	
B10	TORQUE CONTROL CAP	S45C	1	ø40x13.5	
C05	CHAIN BUCKET	PLASTIC	1	90x90x162L	Lift : Max.5m
C06	SOCKET HEAD CAP BOLT	PUR.	1	M6x55	
C07	LOCK NUT	PUR.	1	M6	
C08	LOAD CHAIN	AISI15B24	-	ø4x15	
E00	CONTROL PART Sub Assy		1	MN-250	
H00	BOTTOM HOOK Sub Assy		1	MN-250	250kg/125kg
H08	SLIP CUSHION	URETHAN	1	ø22x12.4	URETHAN+STEEL WASHER
H09	CHAIN STOP HOLDER B	SGP	3	ø21.7x2.6Tx25L	
H10	CHAIN STOP HOLDER A	S45C	1	250kg(125kg)	
H11	SOCKET HEAD CAP BOLT	PUR.	1	M5x25	
H12	LOCK NUT	PUR.	1	M5	
T00	TOP HOOK Sub Assy		1	MN-250	250kg/125kg
T08	TOP HOOK PIN	S45C	1	ø20x90L	
T09	LOCK NUT	PUR.	1	M8	
P00	PUSH BUTTON Sub Assy		1	MN-250	
OIL	GEAR OIL	PUR.	1	250cc	MEROPA 220



# Exploded View

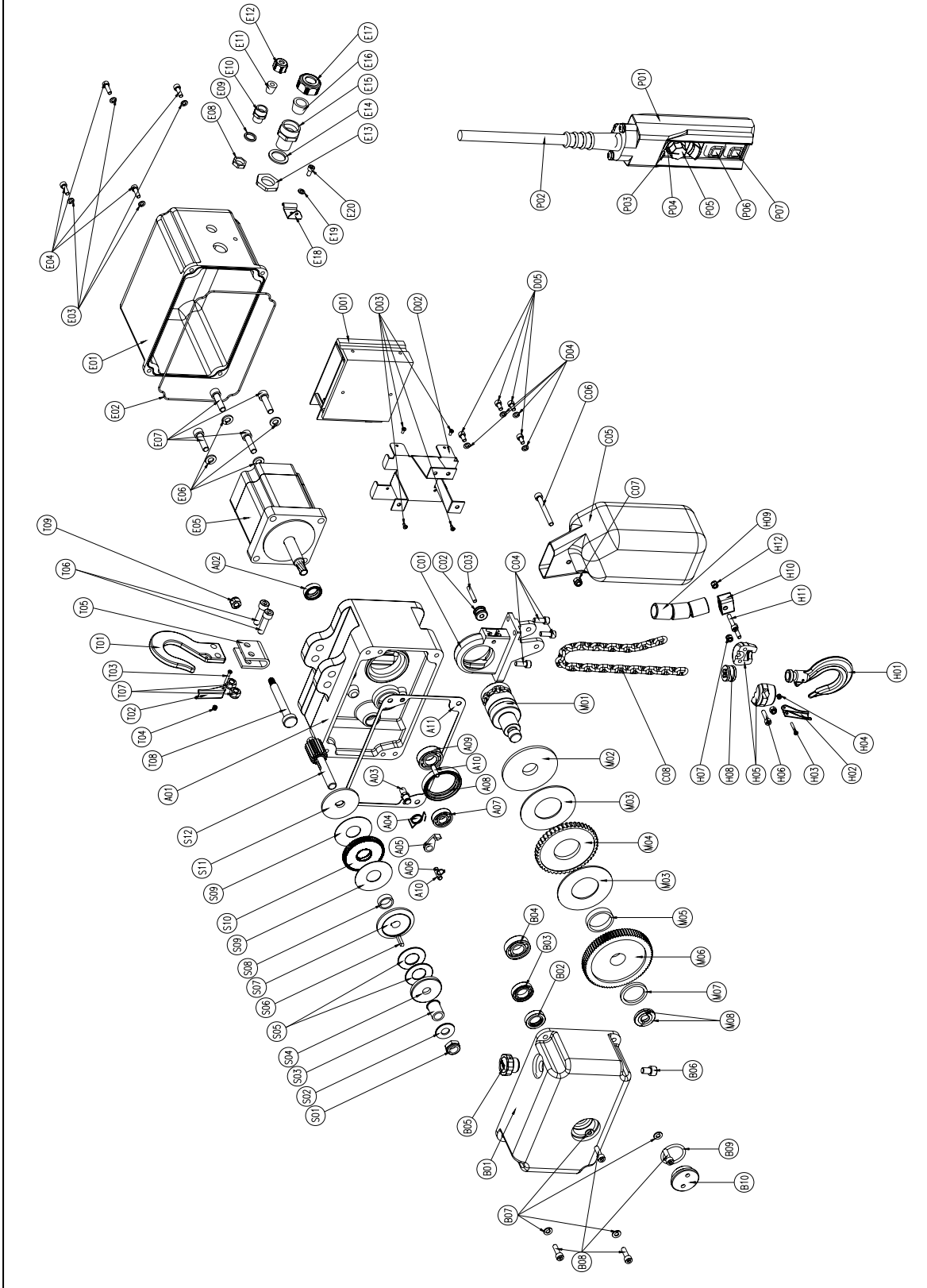

## PRODUCTS

- ELCTRIC CHAIN HOIST(0.5~30ton)
- ELCTRIC CHAIN HOIST(0.25ton)
  - MINI HOIST
- CHAIN BLOCK(0.5~30ton)
- LEVER BLOCK(0.75~6ton)
- CRANE :
  - SUSPENSION CRANE
  - OVER HEAD CRANE
  - JIB CRANE
  - GANTRY CRANE
- GEARED & PLAIN TROLLEY(0.5~30ton)
- GEARED MOTOR(0.4Kw,0.75Kw,1.5Kw)
- END CARRIAGE(SADDLE)
- LOAD CHAIN