

Missing Parts? Assembly Questions?

Call us at 1-866-816-3822 or email help@regencyof.com for immediate assistance.

REGENCY

RGS
FURNITURE

TVCTRC14452XX
Regency Prestige 144in. x 52in.
Conference Table

PL-CTRC14452XX
Parliament 144in. x 52in.
Conference Table

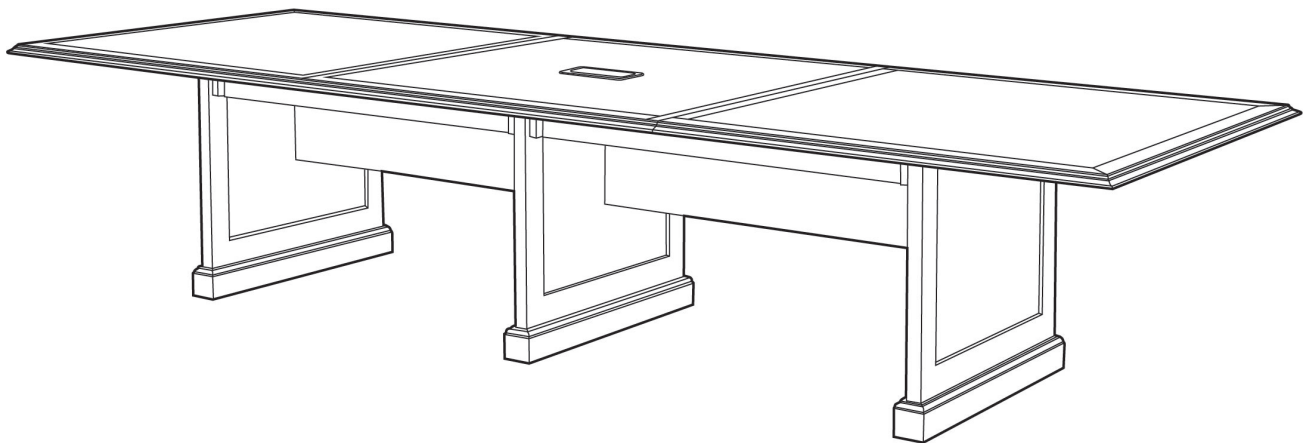

IMPORTANT NOTICE:

Place all wooden parts on a clean and smooth surface such as a rug or carpet to avoid scratching the parts.
Check to be sure that you have all parts and hardware.
Remove all wrapping materials, including staples & packing straps before you start to assemble.
Keep all hardware parts and packaging out of reach of children.
Two person assembly recommended.

Product Care and Usage

Thank you for choosing Regency.

This piece of furniture was manufactured by Regency Seating Inc. With minimal care, your furniture will provide you years of quality service. Your satisfaction is important to us. If you need assistance with any of the below instructions, please contact our customer service department at 866-816-9822 or email us at customerservice@regencyof.com.

General

Your furniture should be dusted frequently using a soft, dry, lint-free cloth, dusting with the direction of the wood grain. Do not use chemicals or abrasive materials to clean surfaces. Regency also recommends the use of desk pads/ mouse pads for high use areas to protect finishes.

Care of Laminate/ Wood/ Veneer Surfaces

Gently wipe the surface to remove any surface dust. Clean with a damp cloth and dry with a lint-free cloth. Do not use furniture polish that contains waxes and oils. Do not use bleach-based cleaners on laminate as it may cause discoloration. While laminate is durable and easily cleaned, avoid using hard bristle brushes which may scratch the laminate surface. Avoid sliding objects over the surface to prevent scratching. The use of coasters is recommended to prevent stains from liquids.

Care of Metal Surfaces

Wipe smooth powder coat finishes and textured metals with a damp cloth. For stubborn stains and grease marks, use soap and water.

Care of Leather/ Vinyl Surfaces

Dust only with a clean, dry, lint-free cloth. Do not use polish, wax, or liquid cleaner.

Care of Fabric Surfaces



Regularly clean your fabric with a vacuum or light brush. For spills, use a damp sponge to blot area. Follow up by blotting with a dry, clean towel. Let air dry. Do not rub or scrub. Heat should never be used when cleaning spills or stains. It can cause stains to set and become permanent.

Care of Plastic/ Polypropylene Surfaces

Clean with a mild soap-and-water solution applied to a clean, lint-free cloth. Gently wipe the surface to remove any surface dust. Wipe dry with a new, clean, lint-free microfiber cloth

Care of Hardware

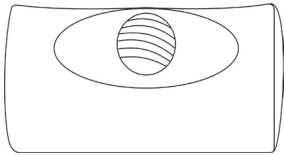
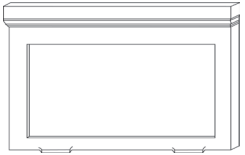
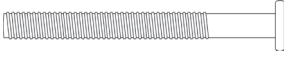
Regularly tighten all nuts, bolts and fasteners. Inspect all joints and fittings to be sure that all are secure. Check and report missing hardware or loose joints.

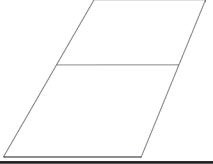
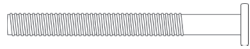
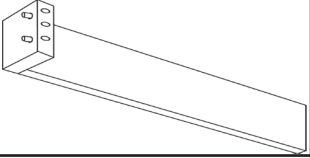
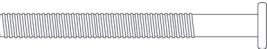
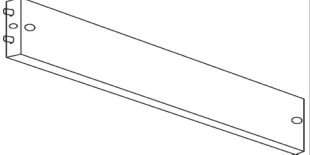
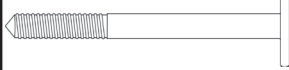
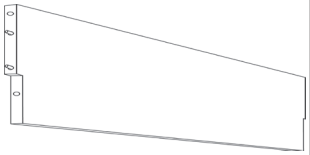
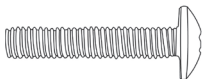
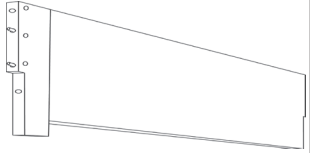
#	Part	Qty	Image	#	Part	Qty	Image
A	Threaded Cams	12		H	Side Legs	2	
B	Large Bolts (2 1/2in.)	12		I	Center Leg	1	
C	Assembly Key / Allen Wrench	1		J	Table Top Halves	2	
D	Medium Bolts (Type A, 1in.)	2		K	Side Stringers (Type A)	2	
E	Medium Bolts (Type B, 1 1/2in.)	2		L	Side Stringers (Type B)	2	
F	Lag Bolts (4 3/4in.)	8		M	Center Stringer (Type A)	1	
G	Small Bolts (5/8in.)	16		N	Center Stringer (Type B)	1	

Step 1: Connect two Table Top Halves (J) together. Align pins. Close Latch to hold halves together.

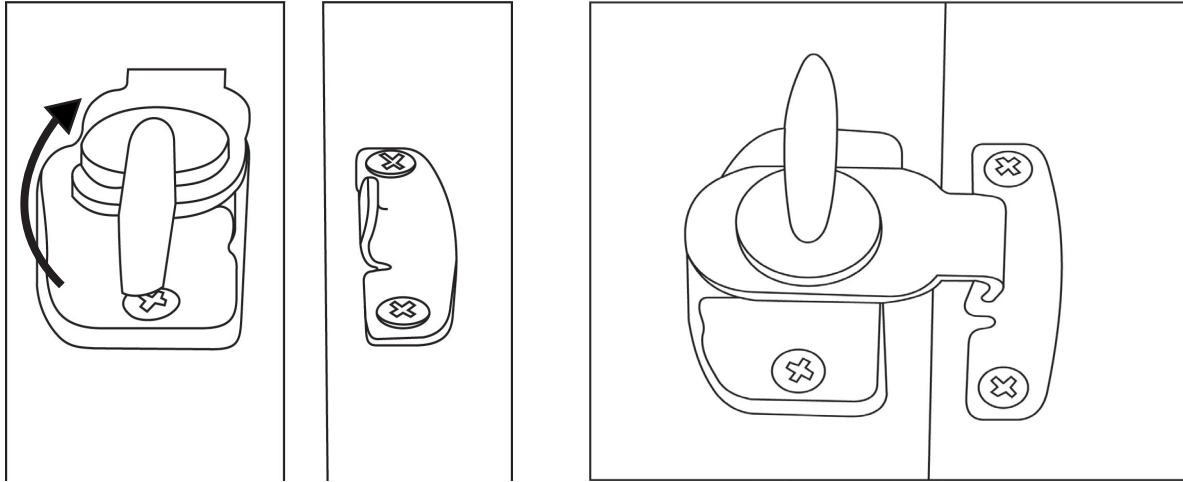

Step 2: Insert Threaded Cams (A) into holes. Holes are located on sides of Side and Center Stringers. Turn so that the longer line on the Cam is horizontal.

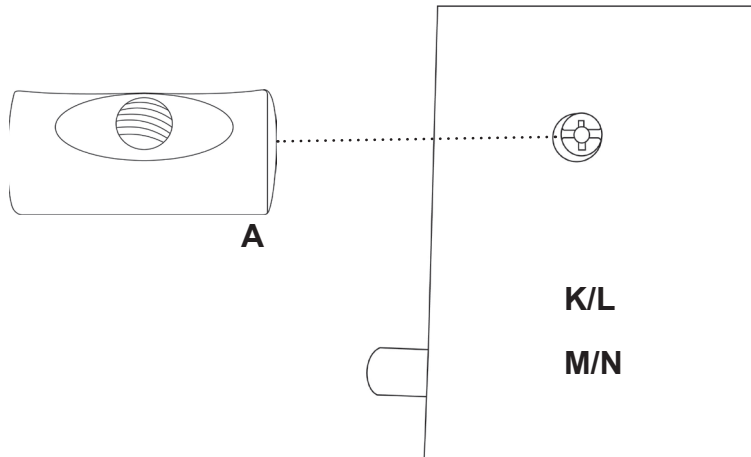

Step 3: Attach Center Leg (I) to Table Top with Small Bolts (G). Do not tighten completely.

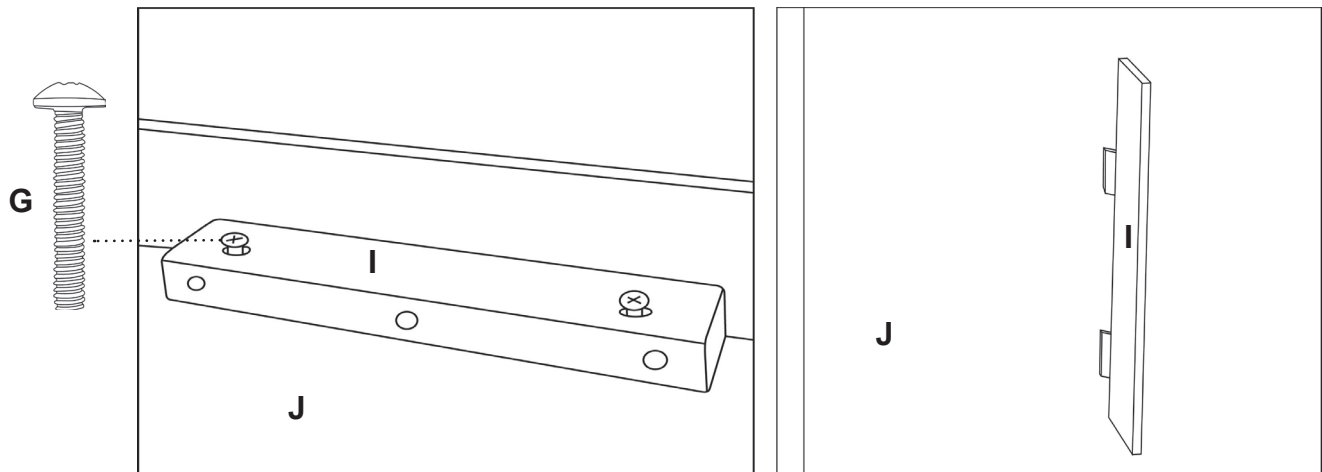

Step 4: Attach Type A Center Stringer (M) to Center Leg (I). Use Type A Medium Bolt (D) for top hole, Type B (E) for bottom.

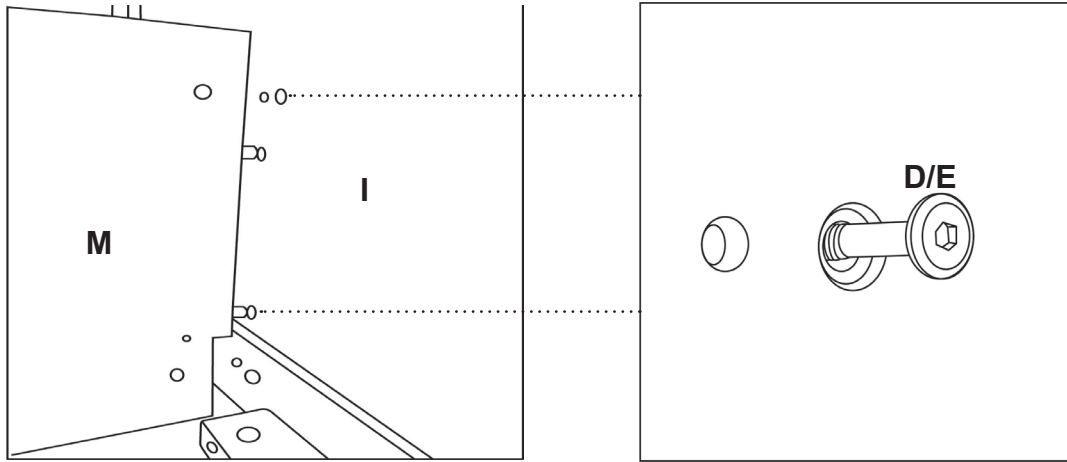

Step 5: Attach Type B Center Stringer (N) to Center Leg (I). Use (D) Bolts for top hole, (E) for bottom.

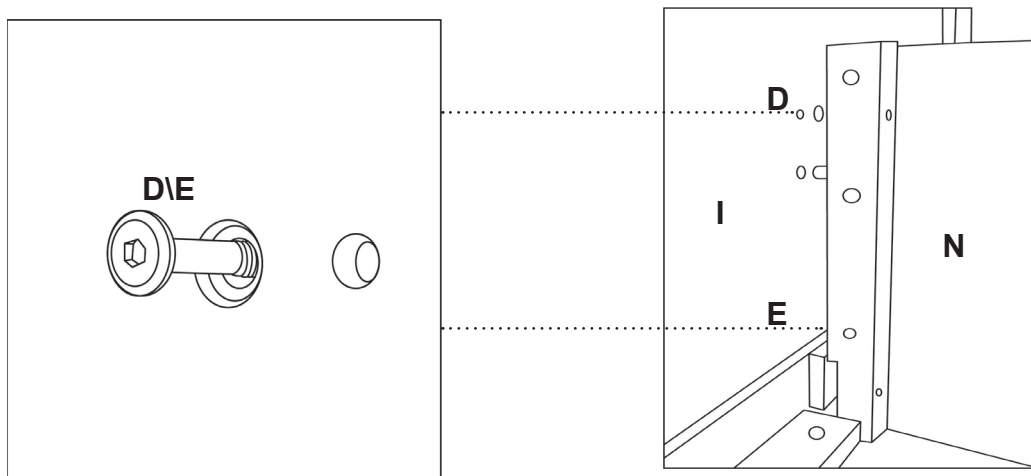

Step 6: Attach Type A Side Stringer (K) to Center Leg (I). Use Large Bolts (B) to secure.

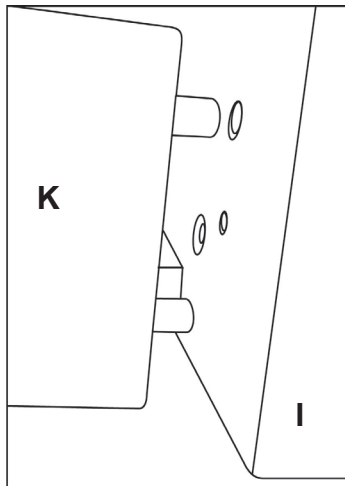

Bolts will thread into Cams, but be careful not to overtighten—Cams may crack wood.

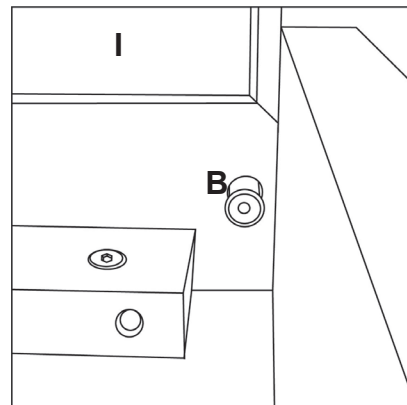

Step 7: Attach Type B Side Stringer (L) to Center Leg (I) with Large Bolts (B).

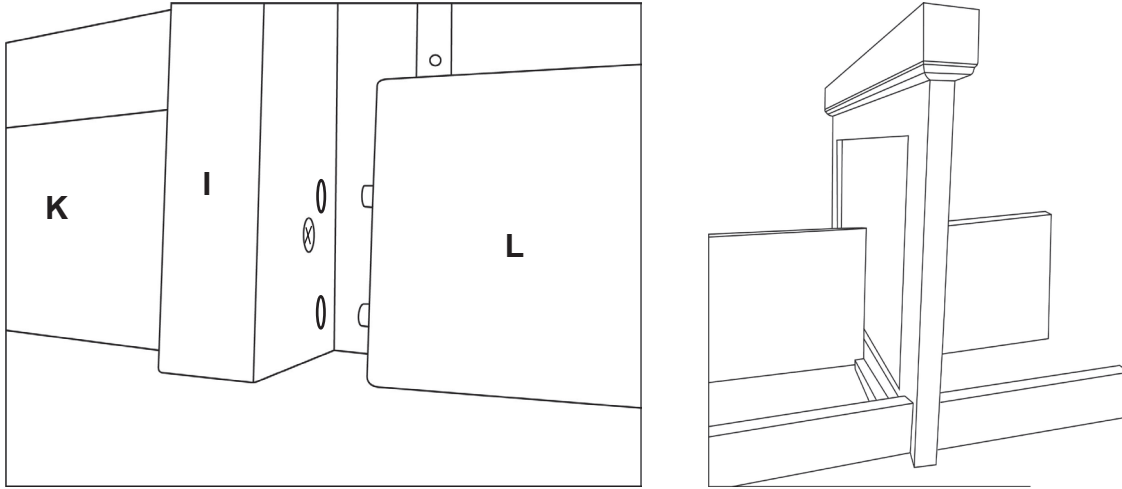

Step 8: Attach Side Legs (H) to Center Stringer and Side Stringers with Large Bolts (B)

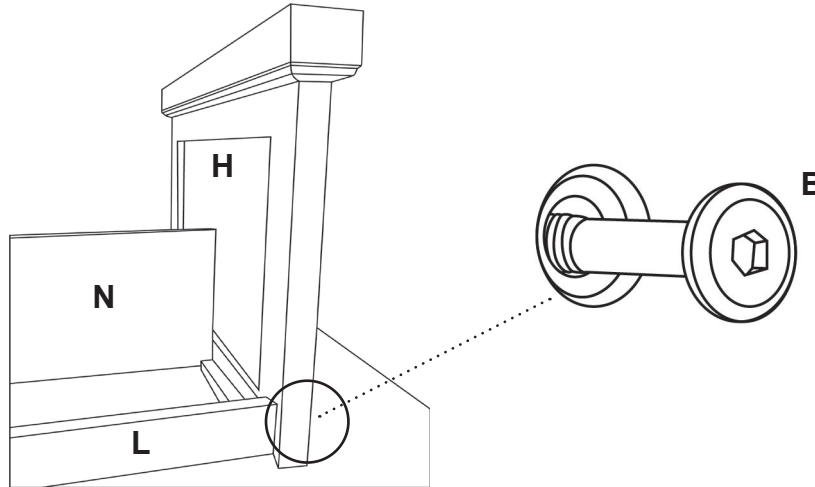

Step 9: Secure Legs to Table Top by tightening bolts.

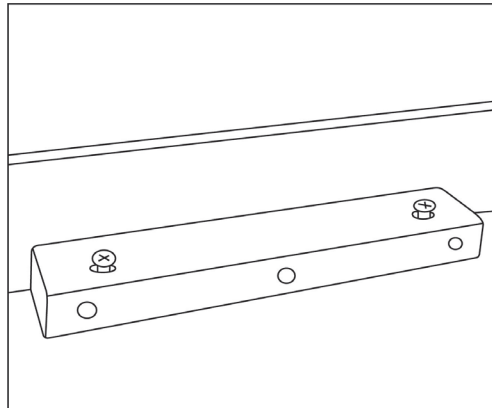

Do not secure to Table Top completely until all Bolts are in place. Be sure to tighten all Bolts after assembly is completed. Do not overtighten.

Step 10: Insert Lag Bolts (F) into Side Stringers and secure to Table Top.

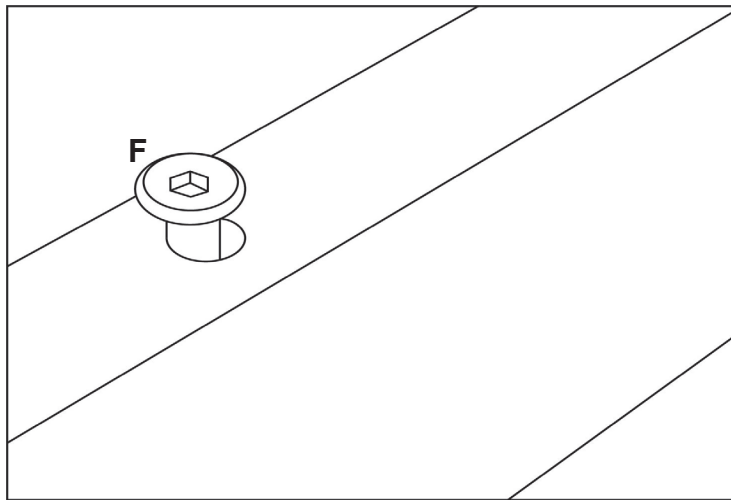

**Thank you for your purchase...
Please be sure to leave a review with your retailer!
Satisfied with your purchase? Be sure to leave us a review.
We appreciate your feedback!**



Regency Facebook: @RegencyOffice
RGS Facebook: @RGSFurniture



Regency Instagram: regencyof
RGS Instagram: @rgs_furniture



Regency Twitter: @RegencyOFA
RGS Twitter: @RGSFurniture