

PARTS LIST				
ITEM	QTY	PART NUMBER	DESCRIPTION	
1	1	LST150-B	1-1/2" POLY T STRAINER BOWL	
2	1	LST150-G	AS568A -336 O-RING, EPDM, BLACK	
4	1	LST225D	DECAL (N/S)	
3	1	LST1550	1 1/2" LST SCREEN 50 Mesh, SS, Poly Ribs	
5	1	MLST150-H	1-1/2"STRNR W/2" MANIFOLD CONN	

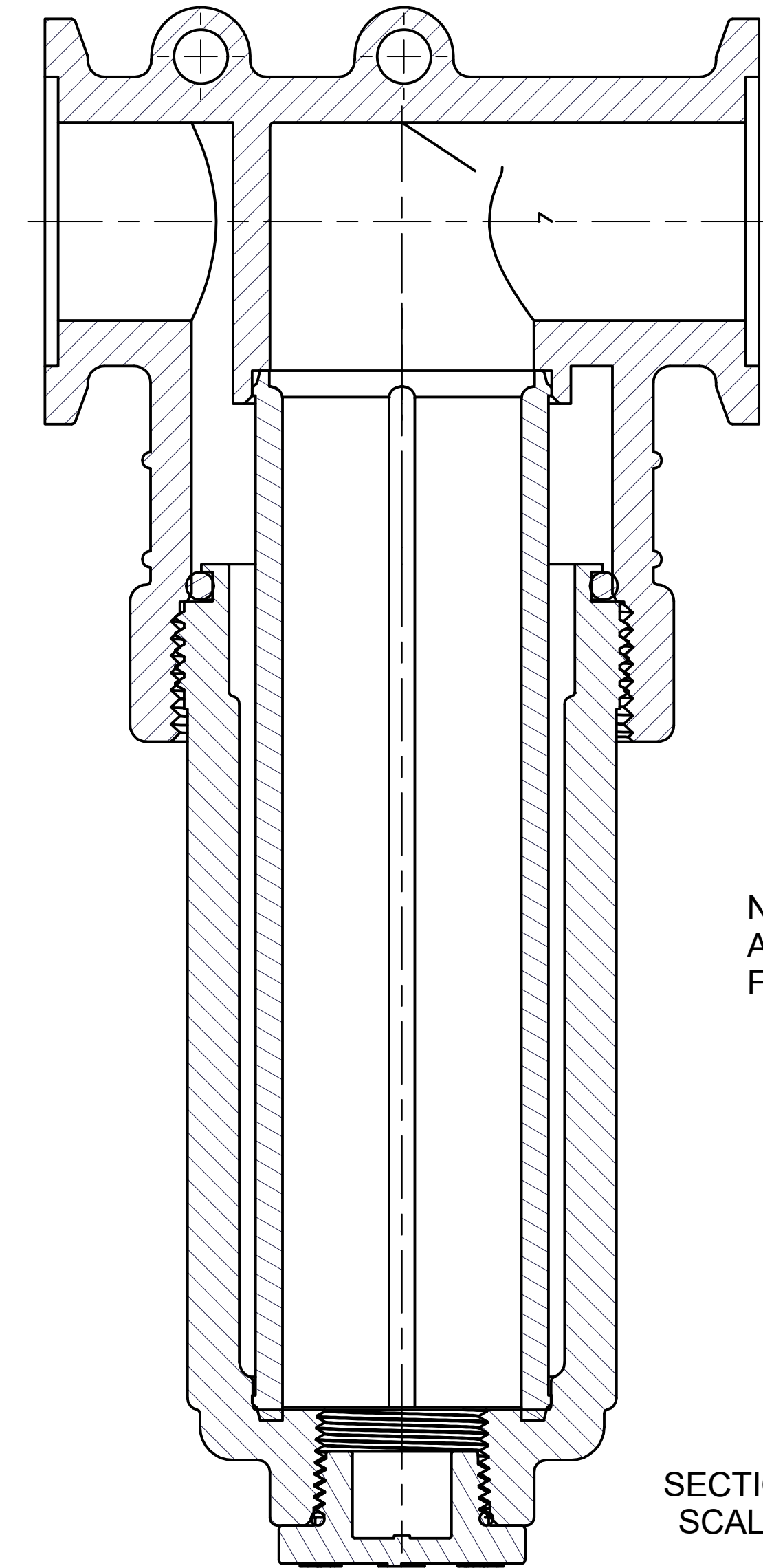

NOTE:
ADDITIONAL CLEARANCE REQ'D
FOR SCREEN REMOVAL: 8"

SECTION B-B
SCALE 1 : 1

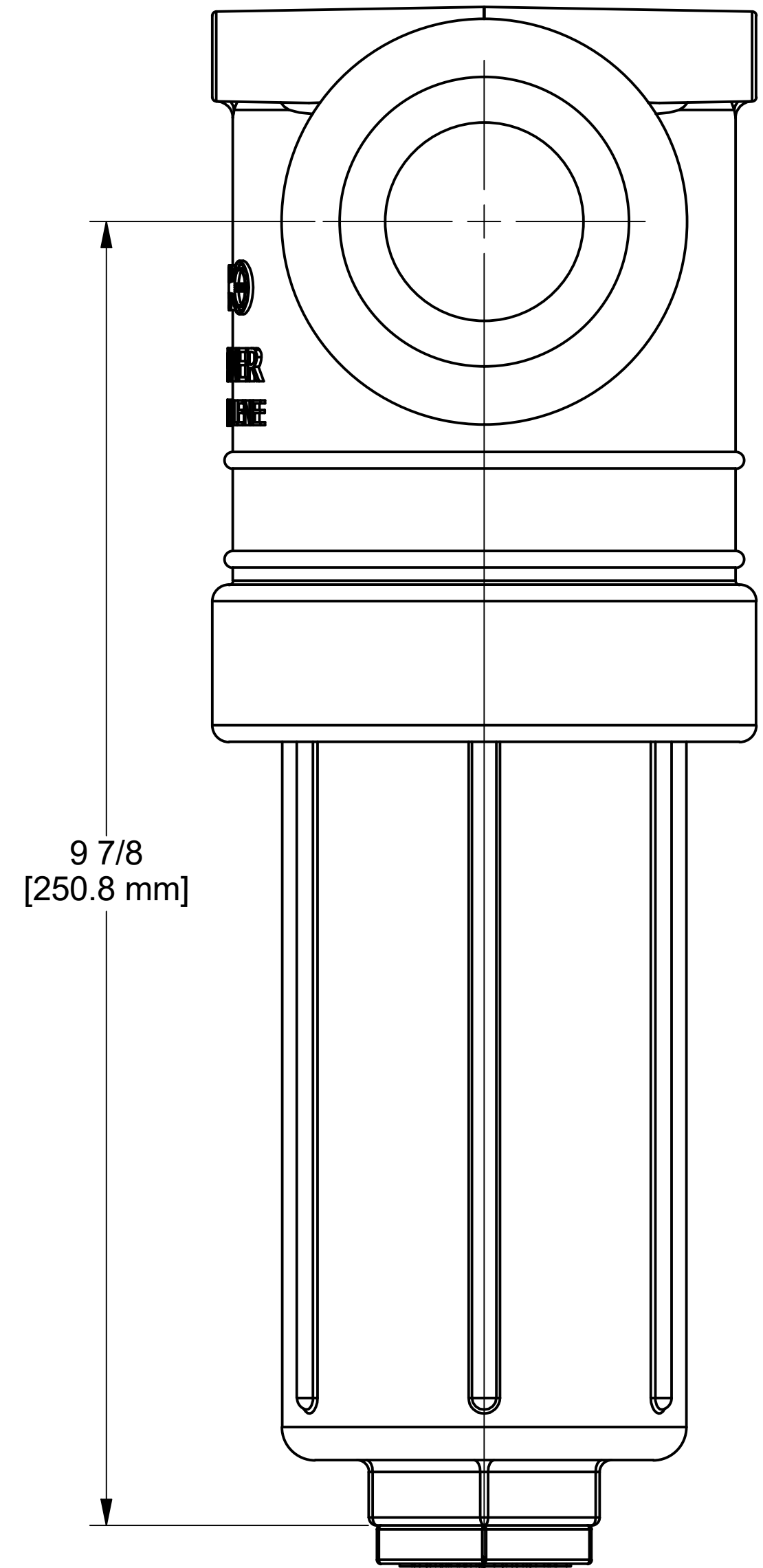
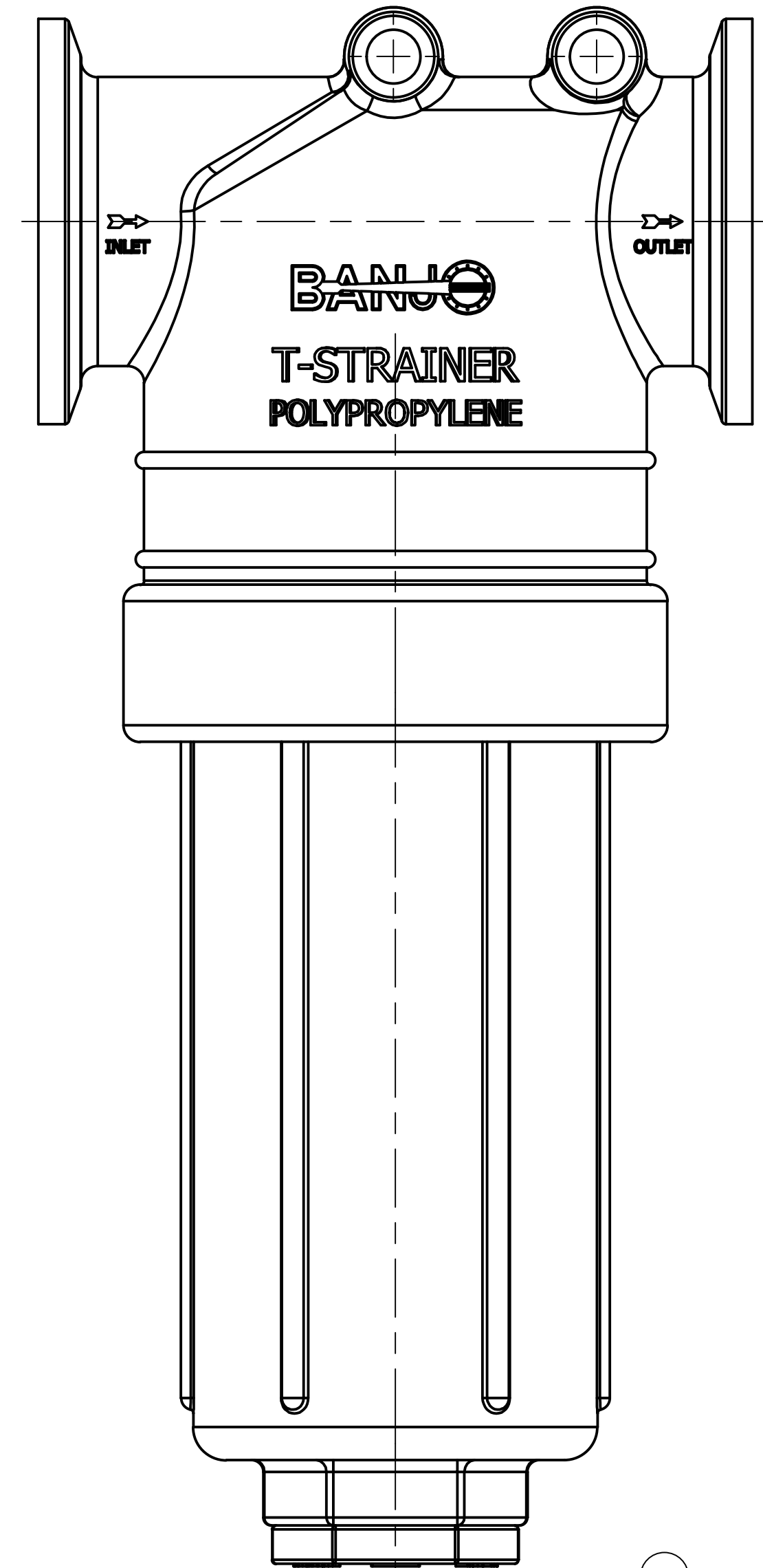
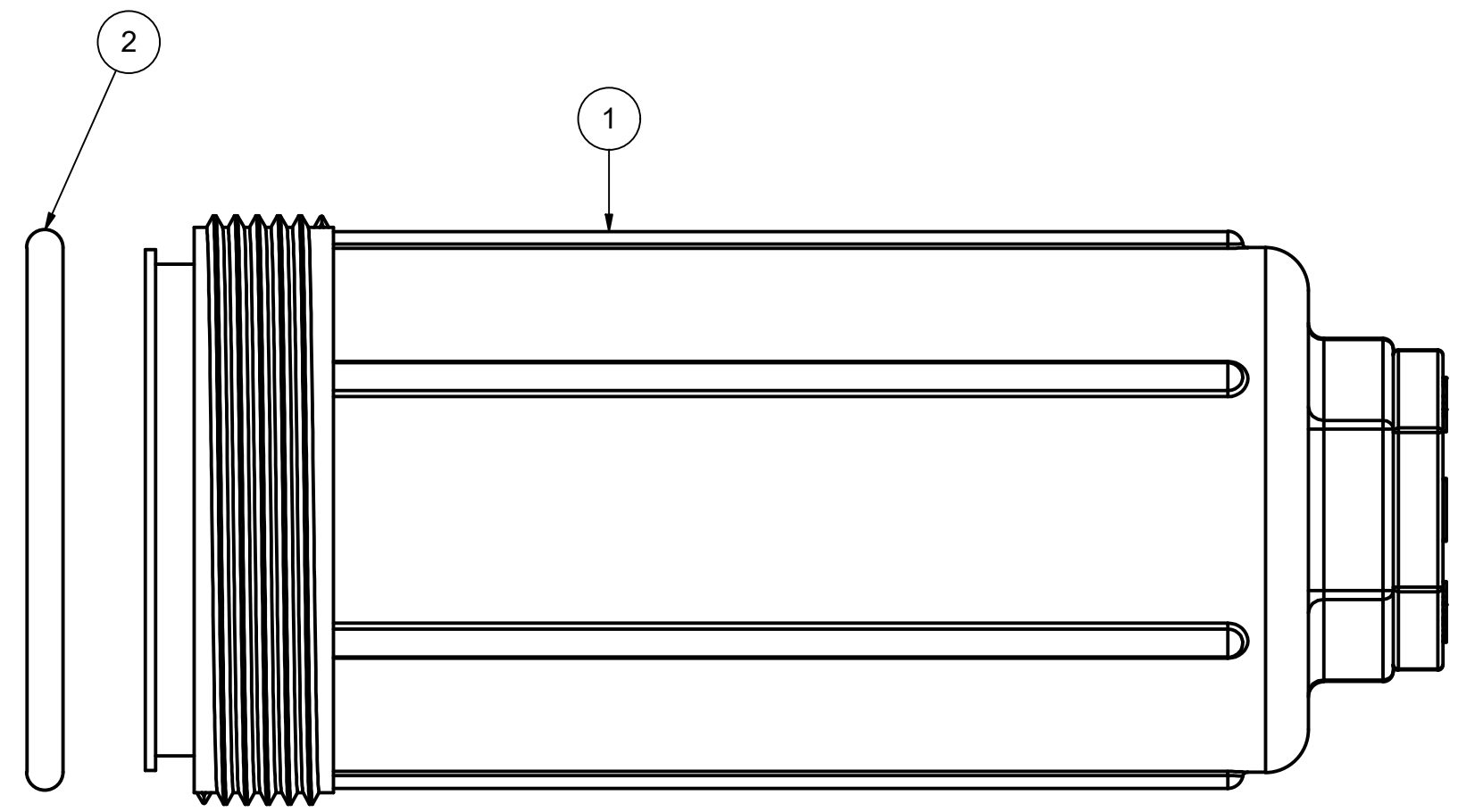
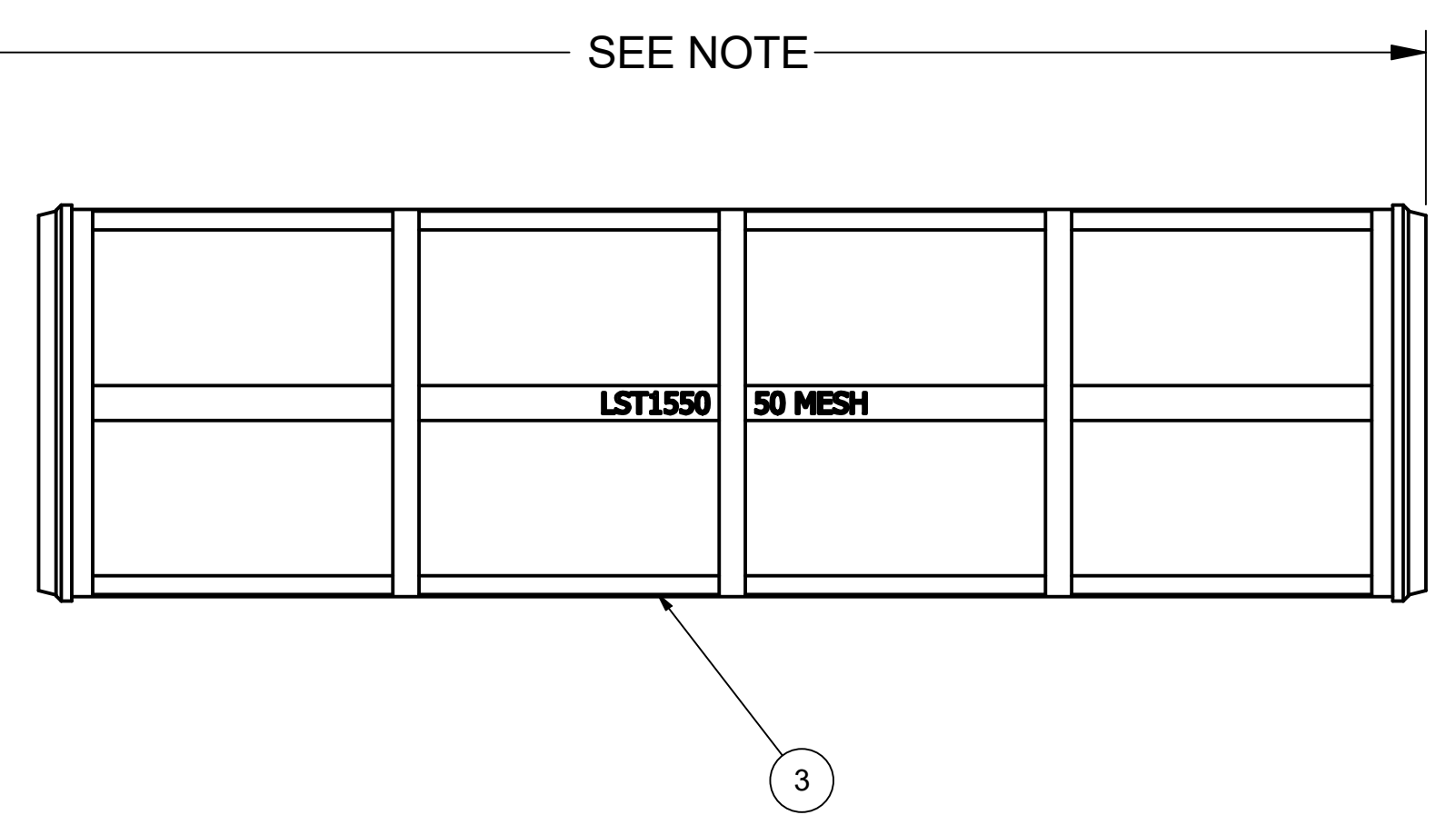
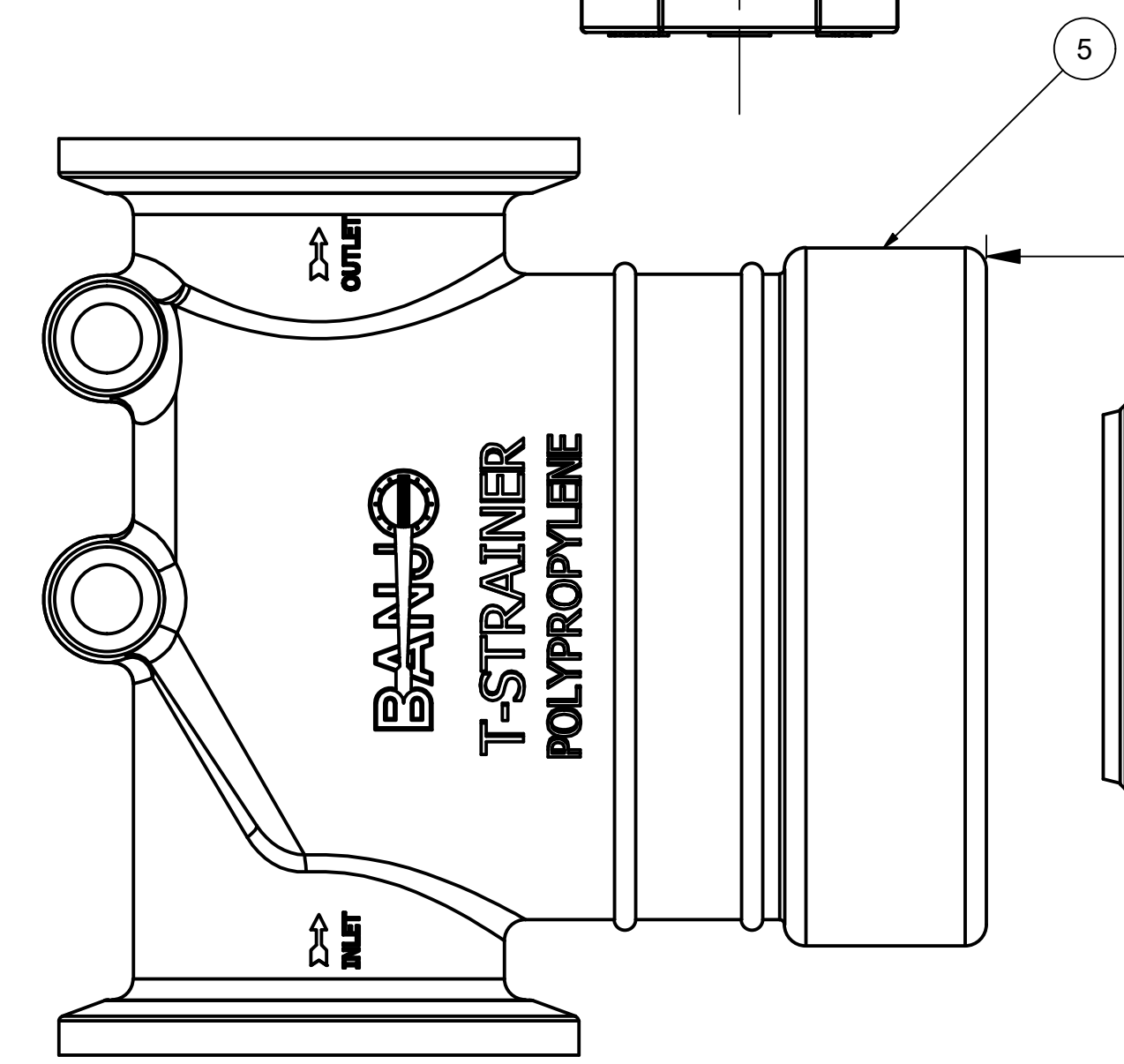

SEE NOTE

THIS DRAWING AND ALL INFORMATION CONTAINED THEREON ARE THE EXCLUSIVE PROPERTY OF BANJO CORPORATION.
UNLESS SPECIFICALLY NOTED, THIS DRAWING AND ITEMS SHOWN ON THIS DRAWING ARE SUBJECT TO CHANGE AT ANY TIME.



BANJO CORPORATION
150 BANJO DRIVE, CRAWFORDSVILLE, IN 47933
WEB SITE: WWW.BANJO.CORP.COM
E-MAIL: BANJOSALES@IDEXCORP.COM

DESCRIPTION
2" STNDRD PORT T STRNR-50 MESH

PART NUMBER
MLST150-50