

Ø4 5/8  
[117.5 mm]

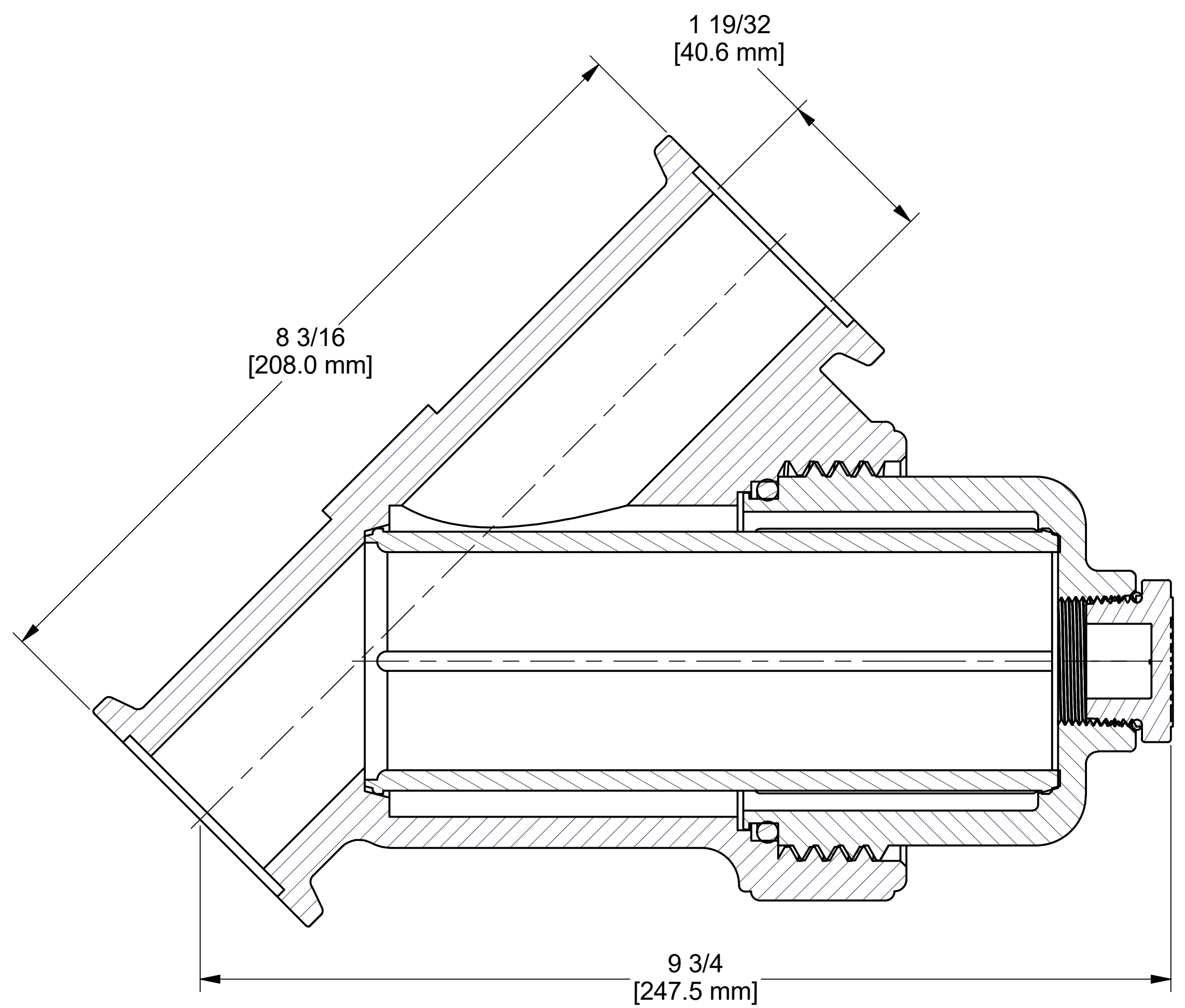

SECTION B-B  
SCALE 1 : 1

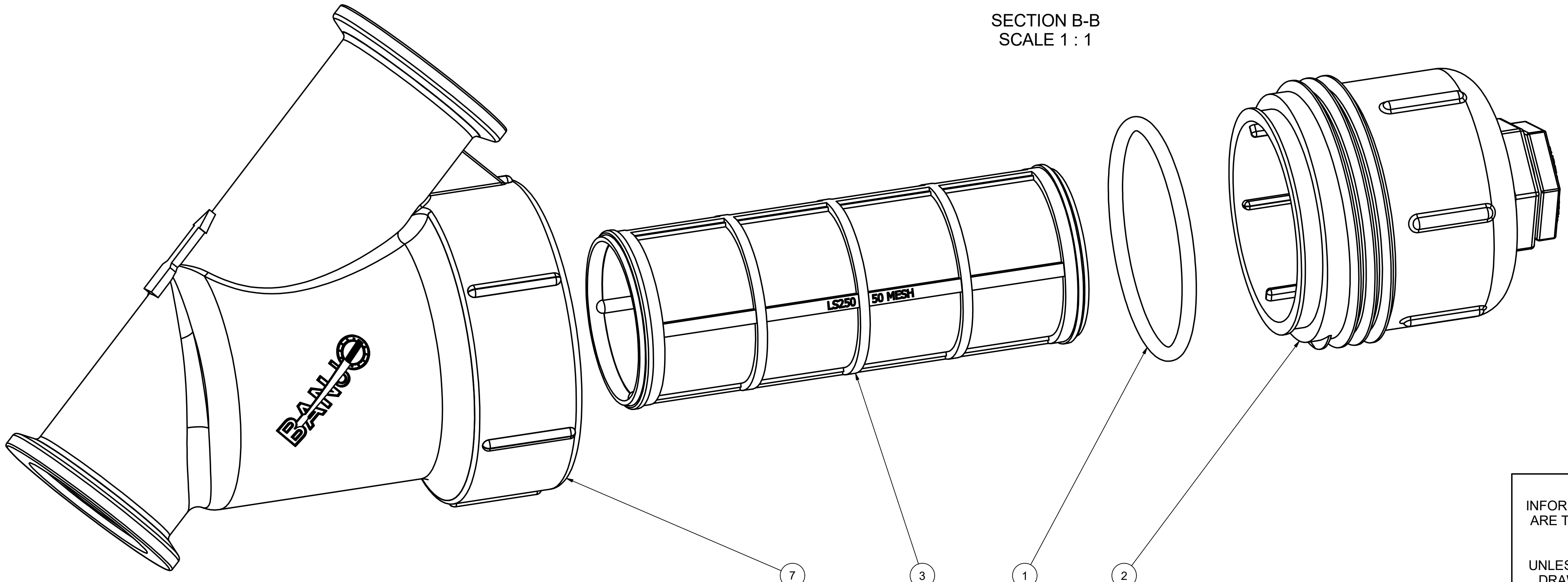

PARTS LIST

ITEM	QTY	PART NUMBER	DESCRIPTION
1	1	LS150-G	AS568A -339 O-RING, EPDM, BLACK
2	1	LS150XC	1 1/2" & 2" LS CAP
3	1	LS250	2" LS SCREEN - 50 MESH
4	1	LSQ200-PL	1" NPT LINE STRAINER PLUG
5	1	LSQ200-R	AS568A -123 O-RING, EPDM, BLACK
6	1	LST225D	DECAL (N/S)
7	1	MLS200B	2" LINE STRAINER BODY



THIS DRAWING AND ALL INFORMATION CONTAINED THEREON ARE THE EXCLUSIVE PROPERTY OF BANJO CORPORATION.  
UNLESS SPECIFICALLY NOTED, THIS DRAWING AND ITEMS SHOWN ON THIS DRAWING ARE SUBJECT TO CHANGE AT ANY TIME.

BANJO CORPORATION  
150 BANJO DRIVE, CRAWFORDSVILLE, IN 47933  
WEB SITE: WWW.BANJO.CORP.COM  
E-MAIL: BANJOSALES@IDEXCORP.COM

DESCRIPTION  
**2"STND PORT FLNG Y STRNR-50MSH**

PART NUMBER  
**MLS200-50**