

# Specification Sheet for Hippo Hopper Model HH32HD

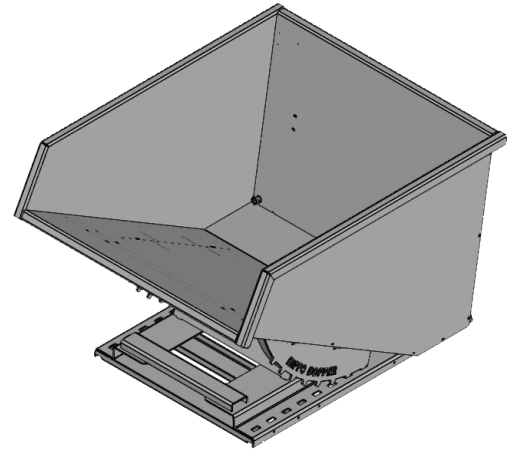

## 2 CU YD HEAVY DUTY HOPPER

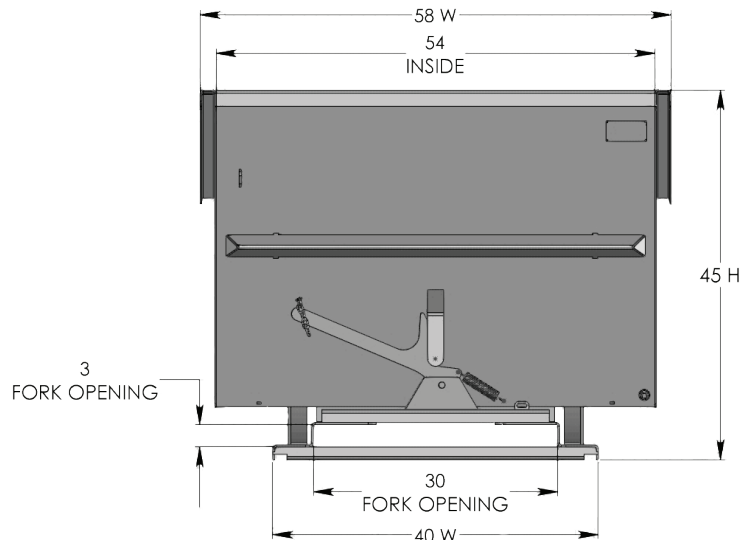
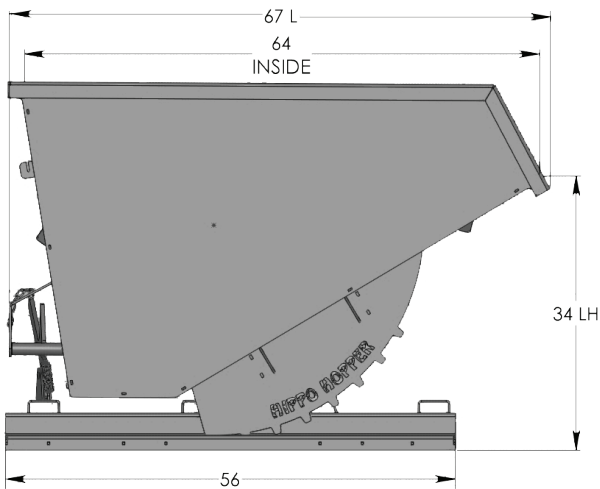

MODEL	SIZE	Weight	L	W	H	LH	CAPACITY
HH32HD	2 CU YD	912 lbs.	67"	58"	45"	34"	6500 lbs.

- Water tight 3/16" Carbon Steel Box with 3/4" drain plug
- 3/8" Laser cut single piece gear style rockers
- 1/4" Formed Steel Base: 40"W x 56"L
- Fork pocket opening: 30"W x 2.75"H
- Formed top rails: 2" x 2"
- Big & Easy pull-down handle release with safety chain



Our heavy duty line of hoppers is the work horse of the industry. Every Hippo Hopper has our unique pull down dump release for added safety, laser cut parts, watertight box and drain plug and will meet and exceed your scrap and bulk handling needs. These hoppers are designed to provide years of dependable service in the toughest applications. They will increase job efficiency, lower labor costs and reduce the possibility of work related back injuries.

Suggested applications: Heavy scrap of all types (metal, glass, stone, etc.) machine shops, fabrication, glass industries, commercial construction and hundreds more end users

Customer Service: (832) 456-4516 or (832) 456-4522 Email: sales@hippohopper.com

The **Hippo Hopper** self-dumping hopper is the fastest, safest, easiest, and most economical way to load, transport and dump scrap and bulk material.

Manufactured by:



Hippo Hopper Plant • 27807 Red Fox Rd. • Tomball, TX 77377  
 FabCorp, Inc. • 6951 West Little York Rd. • Houston, TX 77040

