

Specification Sheet for Hippo Hopper Model HH08-LF-DUST

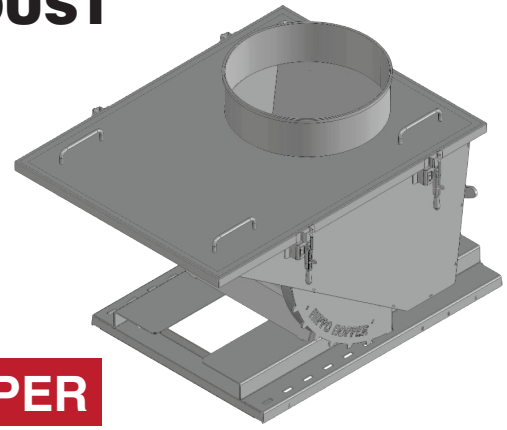

1/2 CU YD DUST CONTAINMENT HOPPER

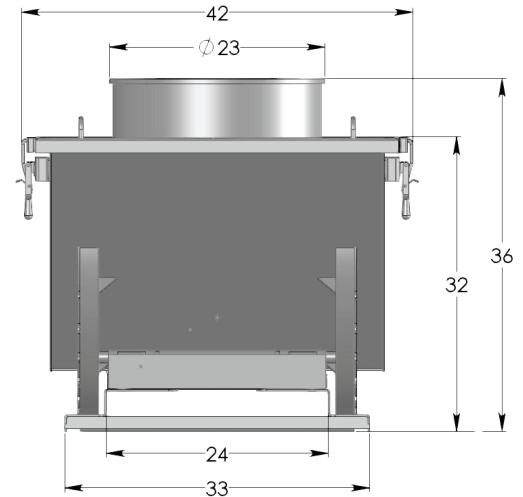
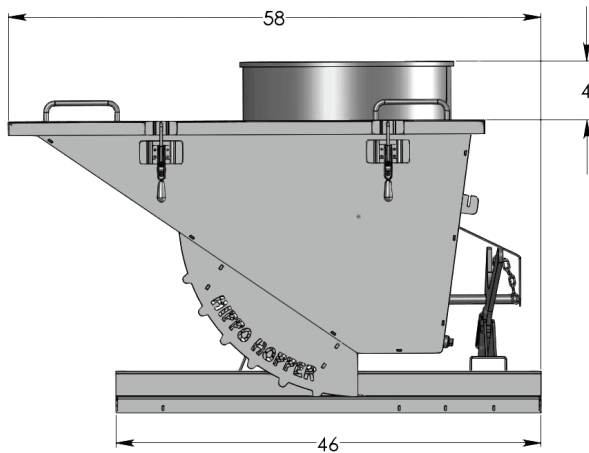

MODEL	SIZE	Weight	L	W	H	LH	CAPACITY
HH08-LF-DUST	1/2 CU YD	315 lbs.	58"	42"	36"	32"	4000 lbs.

Special Features:

- Removable Single Piece steel lid with dust collar
- Rubber gasket to seal hopper located on underside of lid
- "J" CLAMPS to pull lid down and seal lid to top of hopper

Hopper Construction:

- Water tight 10 Gauge Carbon Steel Box with 3/4" drain plug
- 3/8" Laser cut single piece gear style rockers
- 3/16" Formed Steel Base: 33"W x 46"L
- Fork pocket opening: 24"W x 2.75"H
- Formed top rails: 1-1/2" x 1-1/2"
- Big & Easy pull-down handle release with safety chain



Hopper Use:

This Dust Containment hopper is specifically designed for the collection and containment of dust particles dropping from the collection hopper of the dust collector.

These units are not air tight and will not hold a vacuum.

Prior to dumping a single lid dust hopper release "J" clamps and manually remove the lid.

All dust containment hoppers can be transported and dumped with a standard fork lift.

IMPORTANT:

The end user must reference and follow Dust Collectors Equipment literature as related to the operation, safety and health hazards associated with various types of manufacturing dust.

Customer Service: (832) 456-4516 or (832) 456-4522 Email: sales@hippohopper.com

The Hippo Hopper self-dumping hopper is the fastest, safest, easiest, and most economical way to load, transport and dump scrap and bulk material.

Manufactured by:



Hippo Hopper Plant • 27807 Red Fox Rd. • Tomball, TX 77377
FabCorp, Inc. • 6951 West Little York Rd. • Houston, TX 77040

