



Vestil Manufacturing Corp.

2999 North Wayne Street, P.O. Box 507, Angola, IN 46703

Telephone: (260) 665-7586 -or- Toll Free (800) 348-0868

Fax: (260) 665-1339

Web: www.vestilmfg.com e-mail: info@vestil.com

DSP-Series Overhead Door Track Protectors Installation Manual



Receiving instructions:

After delivery, remove the packaging from the product. Inspect the product closely to determine whether it sustained damage during transport. If damage is discovered, immediately record a complete description of the damage on the bill of lading. If the product is undamaged, discard the packaging.

Note:

The end-user is solely responsible for confirming that product design complies with all laws, regulations, codes, and mandatory standards applied where the product is used.

Table of Contents

Specifications.....	2
Signal Words.....	2
Safety Guidelines.....	2
Installation.....	3
Limited Warranty.....	4

Specifications:

The following table provides dimensions and weights of each guard and anchoring hardware kit.

Model	Overall height (H)	Mounting plate dimensions	Anchor bolt hole diameter	Net weight
DSP-24	24 1/4"	6" x 6" with 3" x 3" square notch	9/16" (for 1/2" anchor bolts)	12 lb.
DSP-36	36 1/4"	6" x 6" with 3"x3" square notch	9/16" (for 1/2" anchor bolts)	17 lb.
DSP-48	48 1/4"	6" x 6" with 3"x3" square notch	9/16" (for 1/2" anchor bolts)	21 lb.

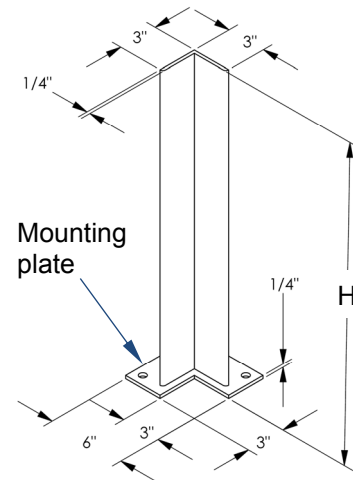

Model	Description	Weight
AS-125	Anchor bolt (1) for concrete: 1/2" x 5"	1 lb.
AS-125-4pk	Anchor bolts (4) for concrete: 1/2" x 5"	4 lb.

Signal Words:

This manual uses SIGNAL WORDS to identify hazards associated with the use of this product. Signal words used in this manual appear below along with their definitions.



Identifies a hazardous situation which, if not avoided, **WILL** result in DEATH or SERIOUS INJURY. Use of this signal word is limited to the most extreme situations.



Identifies a hazardous situation which, if not avoided, **COULD** result in DEATH or SERIOUS INJURY.



Indicates a hazardous situation which, if not avoided, **COULD** result in MINOR or MODERATE injury.



Identifies practices likely to result in product/property damage, such as operation that might damage the product.

Safety Guidelines:

Vestil strives to identify the foreseeable hazards of using its products, but no manual can address every conceivable risk.



DO NOT modify the protector. Modifications automatically void the Limited Warranty (p. 4) and might make the product unsafe to use.



If this product is installed improperly or carelessly, it will not protect overhead door track as intended.

- **Read and understand the entire manual before assembling and using this product.**
- Each protector must be solidly anchored to the ground with three (3) anchor bolts. Anchor bolts should be 1/2" (diameter) by at least 5" (length).
- Install the protectors with the overhead door *closed*. The protectors must not interfere with normal door operation.

Installation:

Install the protector close to overhead door track. Close the door first to make sure that the protector is placed where it will not interfere with door operation. The protector should be located where it will protect the lateral and front sides of the track (see diagram below). When you have selected a location, mark the floor with the location of the bolt holes (in the mounting plate). Drill holes, set the protector in place, and install the anchor bolts. The diagram (below) indicates how each protector should be oriented around the door track.

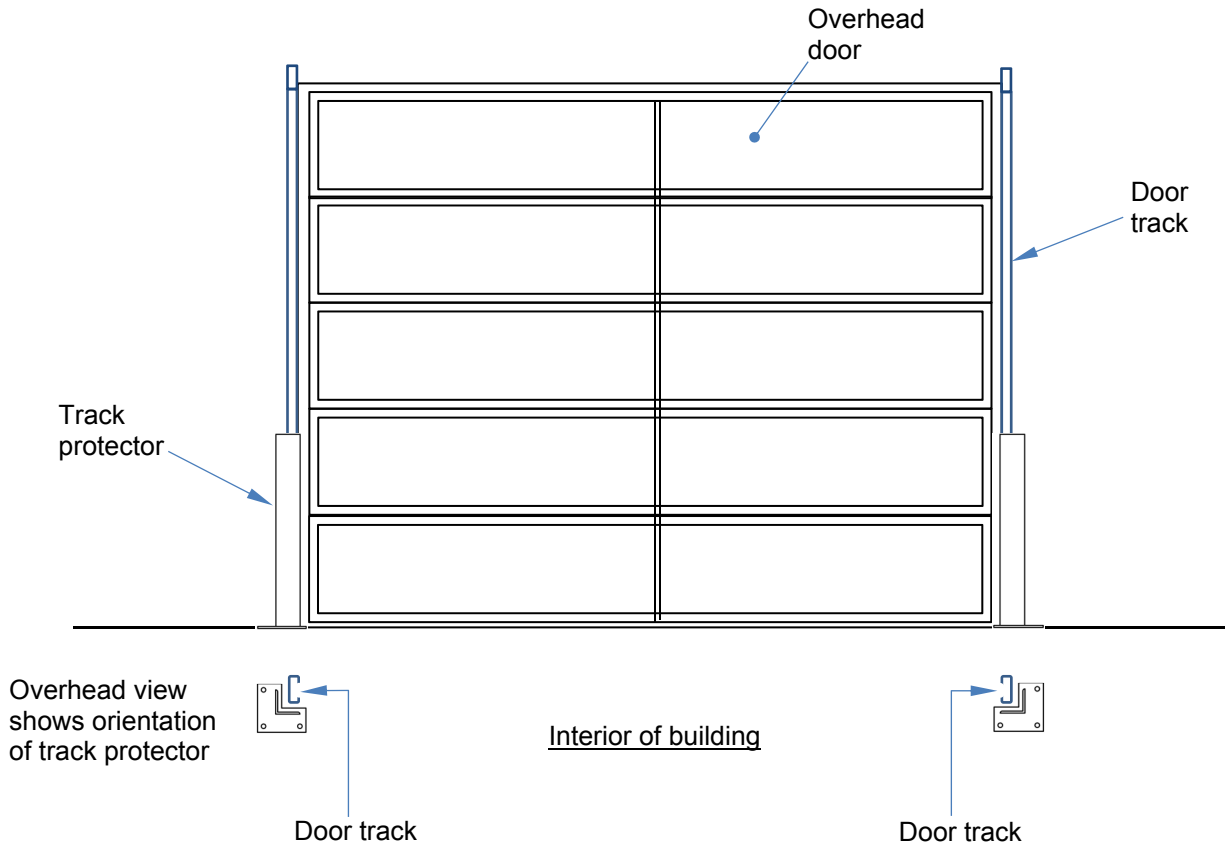

LIMITED WARRANTY

Vestil Manufacturing Corporation (“Vestil”) warrants this product to be free of defects in material and workmanship during the warranty period. Our warranty obligation is to provide a replacement for a defective original part if the part is covered by the warranty, after we receive a proper request from the warrantee (you) for warranty service.

Who may request service?

Only a warrantee may request service. *You are a warrantee if* you purchased the product from Vestil or from an authorized distributor AND Vestil has been fully paid.

What is an “original part”?

An original part is a part used to make the product as shipped to the warrantee.

What is a “proper request”?

A request for warranty service is proper if Vestil receives: 1) a photocopy of the Customer Invoice that displays the shipping date; AND 2) a written request for warranty service including your name and phone number. Send requests by any of the following methods:

Mail
Vestil Manufacturing Corporation
2999 North Wayne Street, PO Box 507
Angola, IN 46703

Fax
(260) 665-1339
Phone
(260) 665-7586

Email
sales@vestil.com

In the written request, list the parts believed to be defective and include the address where replacements should be delivered.

What is covered under the warranty?

After Vestil receives your request for warranty service, an authorized representative will contact you to determine whether your claim is covered by the warranty. Before providing warranty service, Vestil may require you to send the entire product, or just the defective part or parts, to its facility in Angola, IN. The warranty covers defects in the following *original* dynamic components: motors, hydraulic pumps, electronic controllers, switches and cylinders. It also covers defects in *original* parts that wear under normal usage conditions (“wearing parts”): bearings, hoses, wheels, seals, brushes, batteries, and the battery charger.

How long is the warranty period?

The warranty period for original dynamic components is 30 days. For wearing components, the warranty period is also 30 days. The warranty period begins on the date when Vestil ships the product to the warrantee. If the product was purchased from an authorized distributor, the period begins when the distributor ships the product. Vestil may extend the warranty period for products shipped from authorized distributors by *up to* 30 days to the duration necessary to account for shipping time.

If a defective part is covered by the warranty, what will Vestil do to correct the problem?

Vestil will provide an appropriate replacement for any *covered* part. An authorized representative of Vestil will contact you to discuss your claim.

What is not covered by the warranty?

1. Labor;
2. Freight;
3. Occurrence of any of the following, which automatically voids the warranty:
 - Product misuse;
 - Negligent operation or repair;
 - Corrosion or use in corrosive environments;
 - Inadequate or improper maintenance;
 - Damage sustained during shipping;
 - Collisions or other incidental contacts causing damage to the product;
 - Unauthorized modifications: DO NOT modify the product IN ANY WAY without first receiving written authorization from Vestil. Modification(s) might make the product unsafe to use or might cause excessive and/or abnormal wear.

Do any other warranties apply to the product?

Vestil Manufacturing Corp. makes no other express warranties. All implied warranties are disclaimed to the extent allowed by law. Any implied warranty not disclaimed is limited in scope to the terms of this Limited Warranty.

