

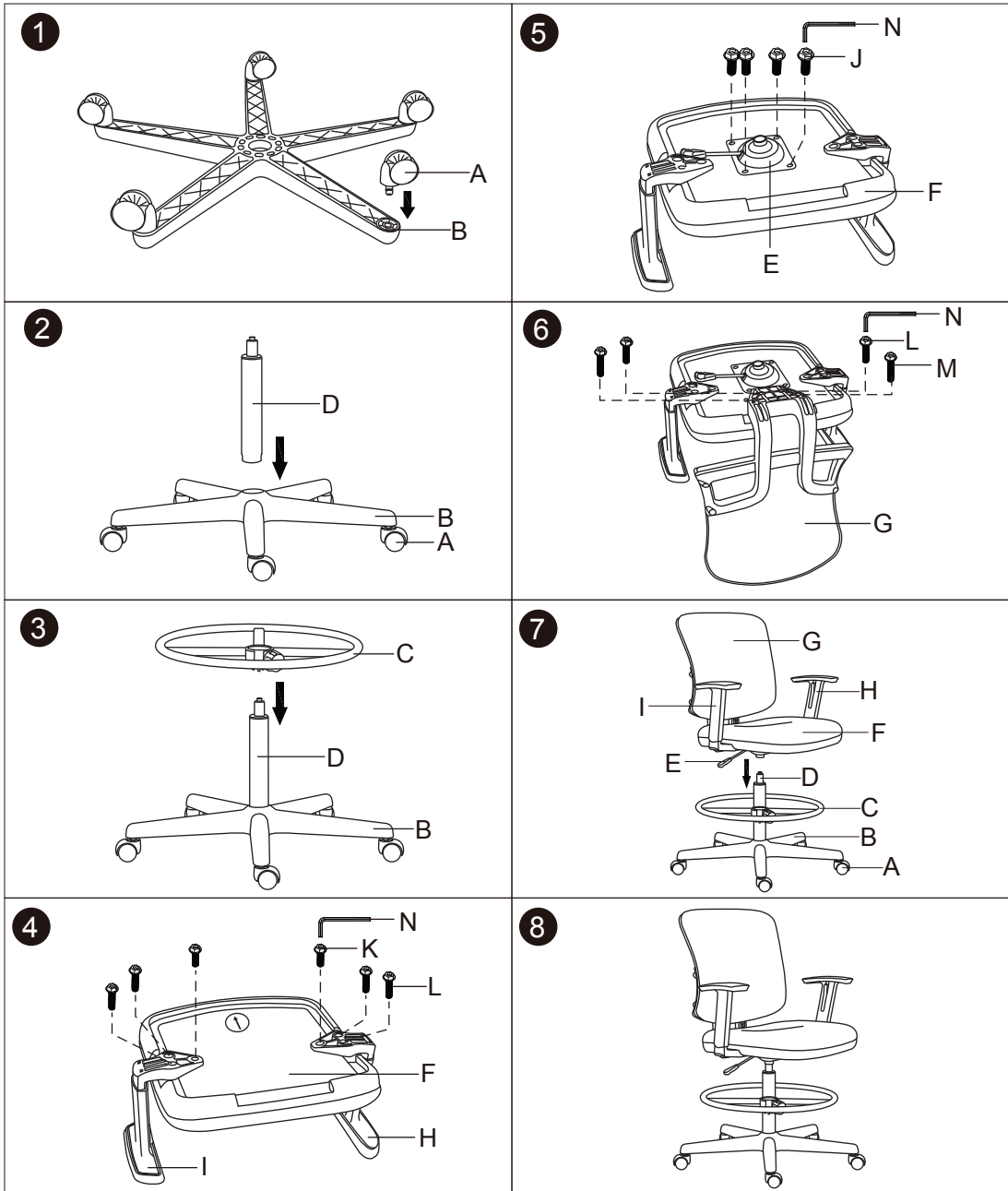







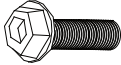
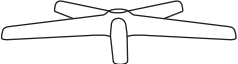

ASSEMBLY INSTRUCTIONS

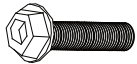

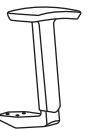
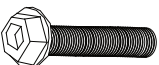
<p>A.</p>  <p>5PCS</p>	<p>F.</p>  <p>1PC</p>	<p>K.</p>  <p>2PCS</p>
<p>B.</p>  <p>1PC</p>	<p>G.</p>  <p>1PC</p>	<p>L.</p>  <p>6PCS</p>
<p>C.</p>  <p>1PC</p>	<p>H.</p>  <p>1PC</p>	<p>M.</p>  <p>2PCS</p>
<p>D.</p>  <p>1PC</p>	<p>I.</p>  <p>1PC</p>	<p>N.</p>  <p>1PC</p>
<p>E.</p>  <p>1PC</p>	<p>J.</p>  <p>4PCS</p>	

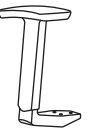
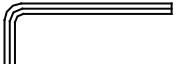
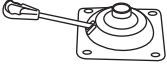
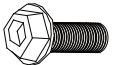
Model: ALE-TE4610/TE4619
 Manufactured for/ Hecho para/ Fabriqué pour Alera®/ Essendant Co.,
 One Parkway North, Deerfield, IL 60015 © 2017 Essendant Co.
 Made in/ Hecho en/ Fabriqué en China
 Product support and parts: 1-800-733-4000
 Ayuda del producto y partes / Support technique et pieces



OPERATING INSTRUCTIONS

ALE-TE4610/TE4619

A. Seat height adjustment

To raise the seat height, stand up from the chair while lifting the lever (A) under the right side of the seat. To lower the seat height, lift the lever (A) while sitting in the chair.

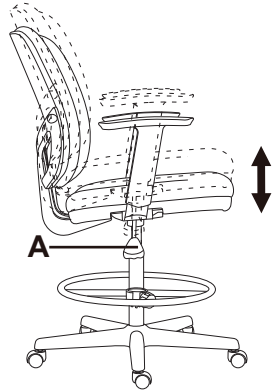

B. Base Ring Height

To raise or lower the base ring height, loosen the knob "B" and adjust to the desired height, then tighten knob "B".

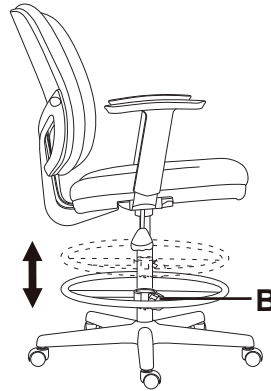

C. Arm height adjustment



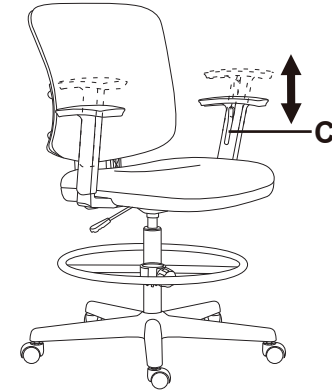



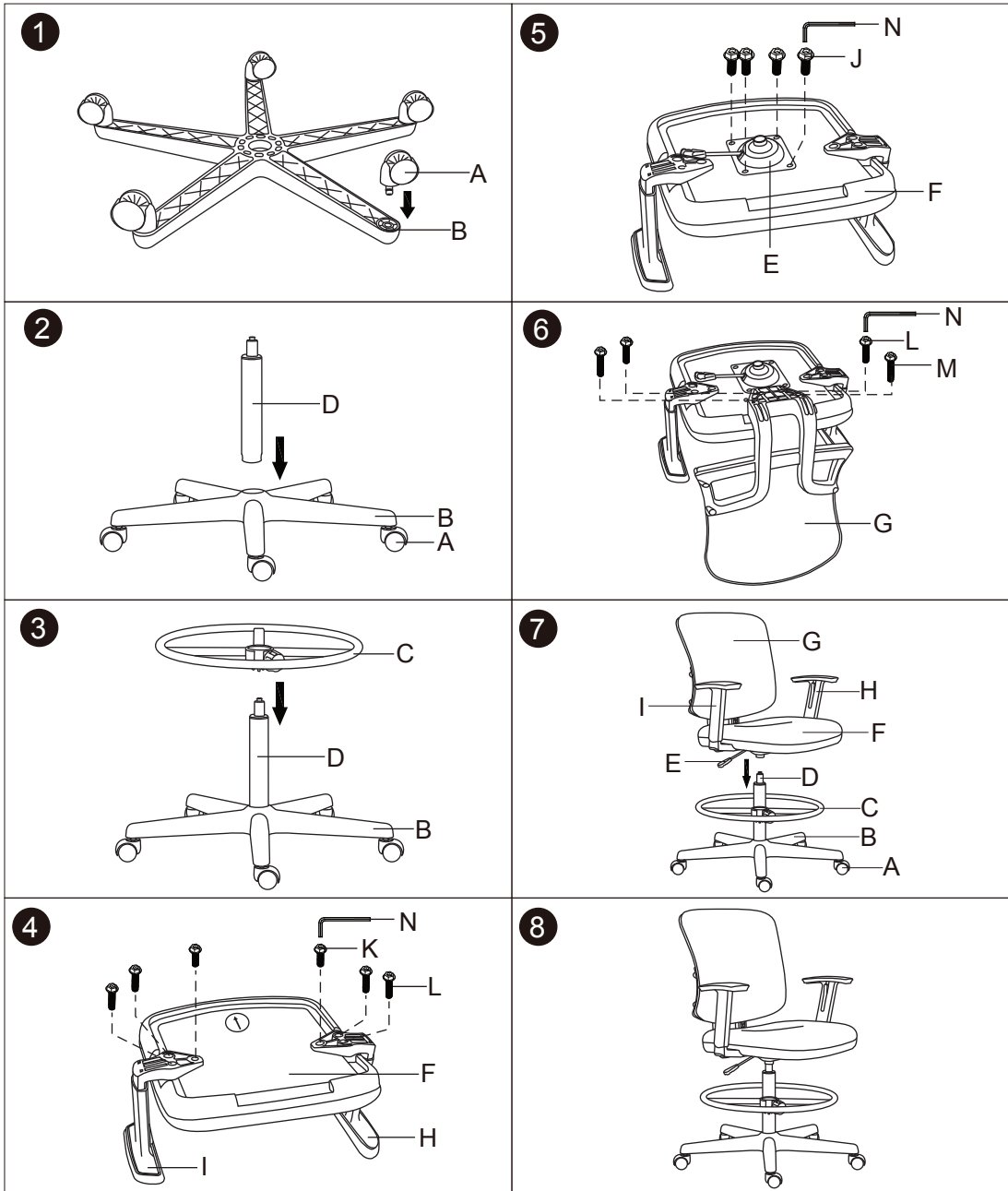

To adjust arm height, push the button (C) on the inside of each arm and move the arm up or down. Release the button (C) to set the height.



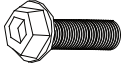
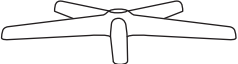

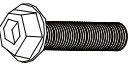
INSTRUCCIONES DE INSTALACIÓN

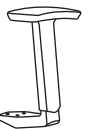
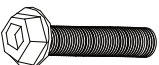

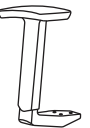
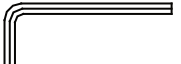
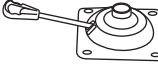
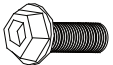
A.  5PZS	F.  1PZ	K.  2PZS
B.  1PZ	G.  1PZ	L.  6PZS
C.  1PZ	H.  1PZ	M.  2PZS
D.  1PZ	I.  1PZ	N.  1PZ
E.  1PZ	J.  4PZS	

Modelo: ALE-TE4610/TE4619
 Manufactured for/ Hecho para/ Fabriqué pour Alera®/ Essendant Co.,
 One Parkway North, Deerfield, IL 60015 © 2017 Essendant Co.
 Made in/ Hecho en/ Fabriqué en China
 Product support and parts: 1-800-733-4000
 Ayuda del producto y partes / Support technique et pieces



INSTRUCCIONES OPERATIVAS

ALE-TE4610/TE4619

A. Ajuste de la altura del asiento

Para subir la altura del asiento, levantarse de la silla mientras se sube el nivel (A) debajo del lado derecho del asiento. Para bajar el asiento, levantar el nivel (A) mientras se está sentado en la silla.

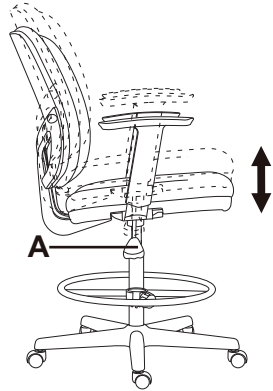

B. Altura del anillo base

Para subir o bajar la altura del anillo base, afloje la perilla "B" y ajuste a la altura deseada, luego apriete el botón "B".

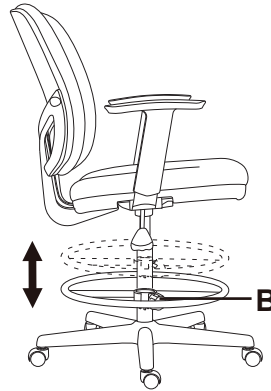

C. Ajuste de la altura del brazo



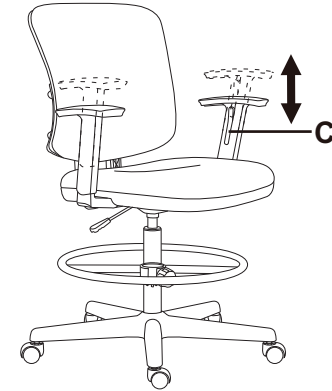



Para ajustar la altura del brazo, pulse el botón (C) en cada brazo y mueva el brazo hacia arriba o hacia abajo. Suelte el botón (C) para fijar la altura.

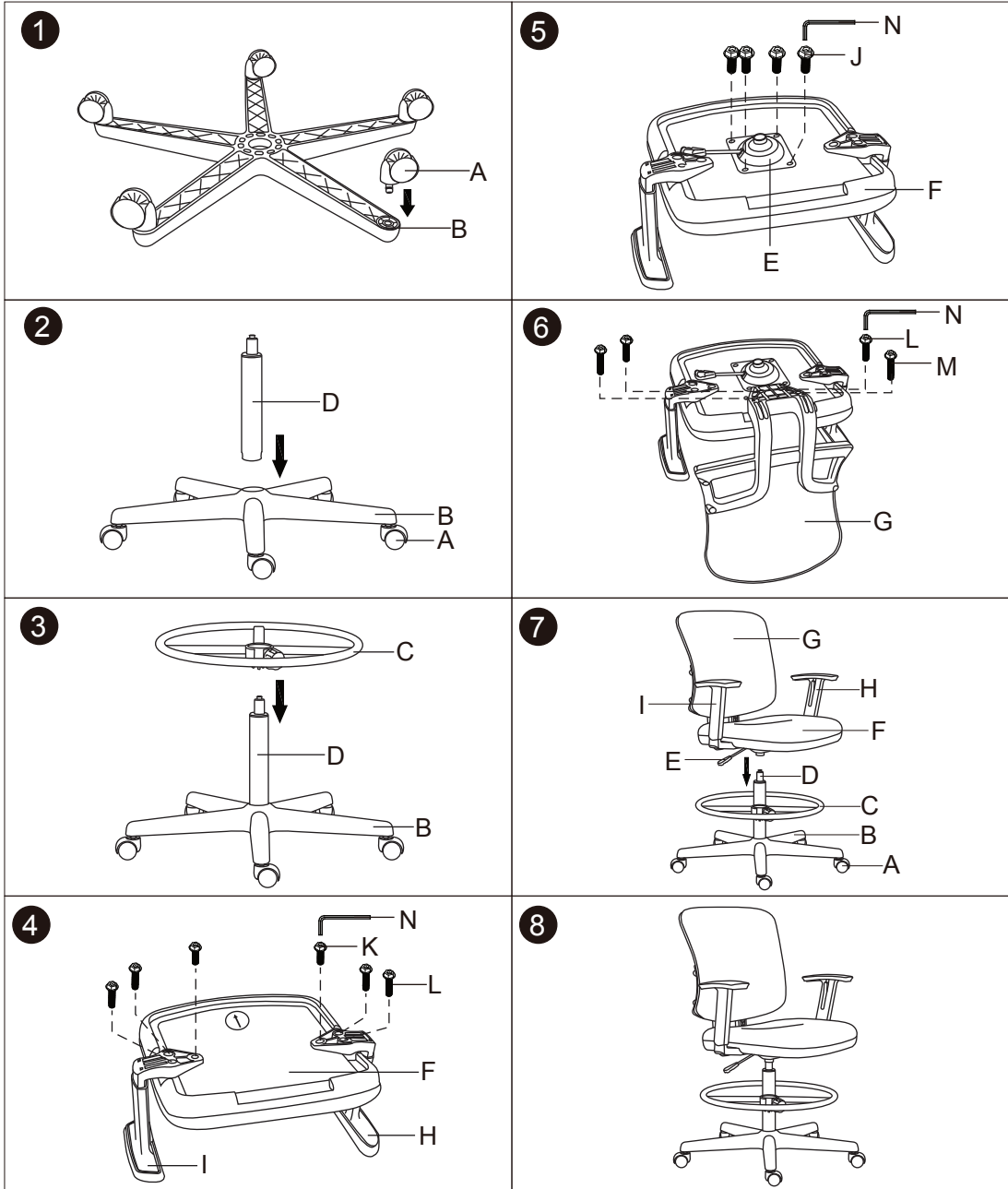

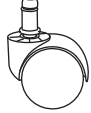

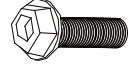
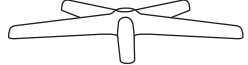
INSTRUCTIONS DE MONTAGE

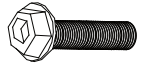
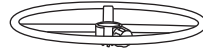
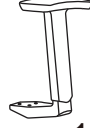
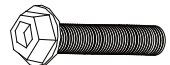

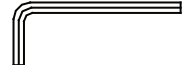
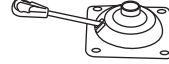
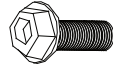
<p>A.</p>  <p>5PIECES</p>	<p>F.</p>  <p>1PIECE</p>	<p>K.</p>  <p>2PIECES</p>
<p>B.</p>  <p>1PIECE</p>	<p>G.</p>  <p>1PIECE</p>	<p>L.</p>  <p>6PIECES</p>
<p>C.</p>  <p>1PIECE</p>	<p>H.</p>  <p>1PIECE</p>	<p>M.</p>  <p>2PIECES</p>
<p>D.</p>  <p>1PIECE</p>	<p>I.</p>  <p>1PIECE</p>	<p>N.</p>  <p>1PIECE</p>
<p>E.</p>  <p>1PIECE</p>	<p>J.</p>  <p>4PIECES</p>	

Modèle: ALE-TE4610/TE4619
 Manufactured for/ Hecho para/ Fabriqué pour Alera®/ Essendant Co.,
 One Parkway North, Deerfield, IL 60015 © 2017 Essendant Co.
 Made in/ Hecho en/ Fabriqué en China
 Product support and parts: 1-800-733-4000
 Ayuda del producto y partes / Support technique et pieces



MODE D'EMPLOI

ALE-TE4610/TE4619

A. Réglage de la hauteur du siège

Pour élever la hauteur du siège, se lever de la chaise tout en soulevant le levier (A) sous le côté droit du siège. Pour abaisser la hauteur du siège, soulevez le levier (A) en position assise sur la chaise.

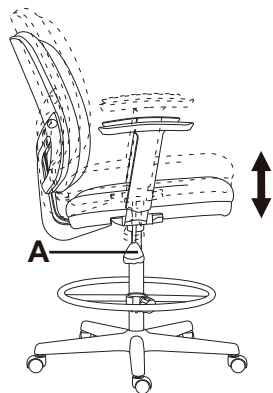

B. Hauteur de l'anneau repose pied

Pour remonter ou baisser l'anneau repose pied, desserrez le bouton B et réglez à la hauteur souhaitée, puis resserrez le bouton B.

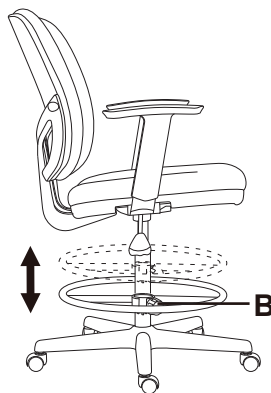

C. Réglage de la hauteur de l'accoudoir

Pour ajuster la hauteur de l'accoudoir, pousser le bouton (C) situé sur chaque accoudoir et déplacer l'accoudoir vers le haut ou le bas. Relâcher le bouton (C) à la hauteur souhaitée.

