



Main

Product	Enclosure
---------	-----------

Complementary

Material	Steel
Height	80 in (2032.00 mm)
Width	20 in (508.00 mm)
Depth	6.5 in (165.10 mm)
Device mounting	Surface
Tightening torque	3 N.m

Environment

Enclosure Rating	NEMA 3R/5/12
Product certifications	CULus

Ordering and shipping details

Category	00110 - RTA PANELBOARD BOXES - SPECIAL, 3R, ETC.
Discount Schedule	PE1A
GTIN	00785901140085
Nbr. of units in pkg.	1
Package weight(Lbs)	135 lb(US) (61.23 kg)
Returnability	Yes
Country of origin	US

Packing Units

Package 1 Height	0.58 ft (0.178 m)
Package 1 width	1.77 ft (0.541 m)
Package 1 Length	6.83 ft (2.083 m)

The information provided in this documentation contains general descriptions and/or technical characteristics of the performance of the products contained herein. This documentation is not intended as a substitute for and is not to be used for determining suitability or reliability of these products for specific user applications. It is the duty of any such user or integrator to perform the appropriate and complete risk analysis, evaluation and testing of the products with respect to the relevant specific application or use thereof. Neither Schneider Electric Industries SAS nor any of its affiliates or subsidiaries shall be responsible or liable for misuse of the information contained herein.

Offer Sustainability

Sustainable offer status	Green Premium product
California proposition 65	WARNING: This product can expose you to chemicals including: Nickel compounds, which is known to the State of California to cause cancer, and Bisphenol A (BPA), which is known to the State of California to cause birth defects or other reproductive harm. For more information go to www.P65Warnings.ca.gov
REACH free of SVHC	Yes
EU RoHS Directive	Compliant EU RoHS Declaration
Mercury free	Yes
RoHS exemption information	Yes
China RoHS Regulation	China RoHS Declaration
Environmental Disclosure	Product Environmental Profile

Contractual warranty

Warranty	18 months
----------	-----------

Approximate Dimensions

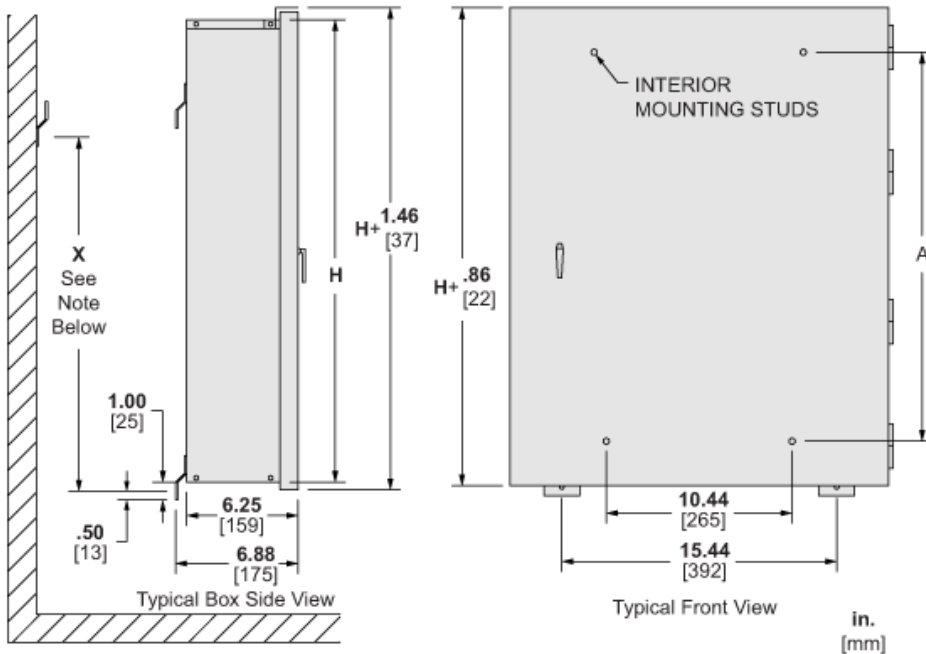

CATALOG NUMBER	BOX HEIGHT		MOUNTING INTERIOR HEIGHT	
	H		A	
	IN	MM	IN	MM
MH26WP	26.00	660	21.00	533
MH32WP	32.00	813	27.00	686
MH38WP	38.00	965	33.00	838
MH44WP	44.00	1118	39.00	991
MH50WP	50.00	1270	45.00	1143
MH56WP	56.00	1422	51.00	1295
MH62WP	62.00	1575	57.00	1448
MH68WP	68.00	1727	63.00	1600
MH74WP	74.00	1880	69.00	1753
MH80WP	80.00	2032	75.00	1905
MH86WP	86.00	2184	81.00	2057

NOTE: FOR "X" DIMENSION, SUBTRACT 6.60/[168] FROM THE BOX HEIGHT.

