

Product data sheet

Characteristics

9070T1500D31

Transformer, Type T, industrial control, 1500 VA, 240/480 VAC primary / 120/240 VAC secondary, 1 phase, 50/60 Hz, 55 °C



Main

| | |
|--------------|--------------------------------|
| Product Type | Industrial Control Transformer |
| Power Rating | 1500 VA |
| Type | T |

Complementary

| | |
|--------------------------------|---|
| Number of Phases | 1 phase |
| Power Rating | 1500 VA UL 1500 VA CSA 1500 VA NOM 1000 VA |
| Temperature Rise | 115 °C |
| Electrical Connection | Screw clamp terminals |
| Height | 6.17 in (156.72 mm) |
| Width | 7.06 in (179.32 mm) |
| Depth | 5.92 in (150.37 mm) |
| Material | Copper winding |
| Fingersafe Cover Compatibility | FSC2 |

Environment

| | |
|------------------------|--|
| Certifications | CSA file LR37055 guide 184-N-90 UL listed file E61239 |
| Enclosure Type | Not rated (open device) |
| Insulation Temperature | 356 °F (180 °C) |

Ordering and shipping details

| | |
|-----------------------|------------------------------------|
| Category | 16201 - 9070 T (NOT TF) 250-2000VA |
| Discount Schedule | CP8 |
| GTIN | 00785901803720 |
| Nbr. of units in pkg. | 1 |
| Package weight(Lbs) | 38 lb(US) (17.24 kg) |
| Returnability | Yes |
| Country of origin | MX |

Packing Units

| | |
|------------------|----------------------|
| Package 1 Height | 12.20 in (30.988 cm) |
| Package 1 width | 11.70 in (29.718 cm) |
| Package 1 Length | 14.70 in (37.338 cm) |

Offer Sustainability

| | |
|----------------------------|---|
| Sustainable offer status | Green Premium product |
| California proposition 65 | WARNING: This product can expose you to chemicals including: Phenyl glycidyl ether, which is known to the State of California to cause cancer and birth defects or other reproductive harm. For more information go to www.P65Warnings.ca.gov |
| EU RoHS Directive | Compliant EU RoHS Declaration |
| Mercury free | Yes |
| RoHS exemption information | Yes |
| China RoHS Regulation | China RoHS Declaration |
| Environmental Disclosure | Product Environmental Profile |
| PVC free | Yes |

Contractual warranty

| | |
|----------|----------|
| Warranty | 10 Years |
|----------|----------|

Approximate Dimensions

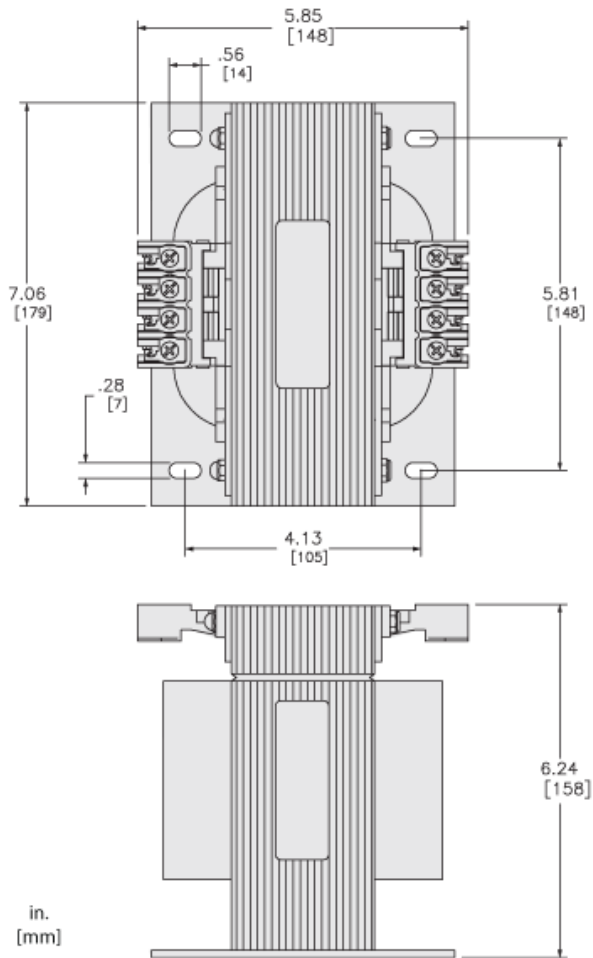

Connections and Wiring Diagrams

Voltage and Connection Options

| Voltage Code | Voltages | | Connections | |
|--------------|-------------------------------------|-------------------------------------|---|---|
| | Primary | Secondary | Primary | Secondary |
| D31 | 220 x 440 230 x 460 240 x 480 | 110/220 115/230 120/240 | 220 or 230 or 240: Connect to H1 and H4 Jumper H1 with H3 Jumper H2 with H4 440 or 460 or 480: Connect to H1 and H4 Jumper H2 with H3 | 110 or 115 or 120: Connect to X1 and X4 Jumper X1 with X3 Jumper X2 with X4 220 or 230 or 240: Connect to X1 and X4 Jumper X2 with X3 |
| D55 | 110 x 220 115 x 230 120 x 240 | 110 x 220 115 x 230 120 x 240 | 110 or 115 or 120: Connect to H1 and H4 Jumper H1 with H3 Jumper H2 with H4 220 or 230 or 240: Connect to H1 and H4 Jumper H2 with H3 | 110 or 115 or 120: Connect to X1 and X4 Jumper X1 with X3 Jumper X2 with X4 220 or 230 or 240: Connect to X1 and X4 Jumper X2 with X3 |

