

Instruction Bulletin

Replaces 80043-687-03 08/2007

ENGLISH

Backfed Main Circuit Breaker Barrier Kit Installation onto an NQ or NF Panelboard Classes 1640 and 1670

Retain for future use.

Introduction

This bulletin contains instructions for installing a Square D® brand backfed main circuit breaker barrier kit onto a Square D brand NQ or NF panelboard manufactured by Schneider Electric.

Safety Precautions

⚠ DANGER

HAZARD OF ELECTRIC SHOCK, EXPLOSION, OR ARC FLASH

- Apply appropriate personal protective equipment (PPE) and follow safe electrical work practices. See NFPA 70E.
- This equipment must only be installed and serviced by qualified electrical personnel.
- Turn off all power supplying this equipment before working on or inside equipment.
- Always use a properly rated voltage sensing device to confirm power is off.
- Replace all devices, doors, and covers before turning on power to this equipment.

Failure to follow these instructions will result in death or serious injury.

Kit Contents

NQODBFMB20 and NFBFMB20

- NQODBFMB20 kit only**–
Backfed main circuit breaker barrier (1)
- NFBFMB20 kit only**–
Backfed main circuit breaker barrier (1)

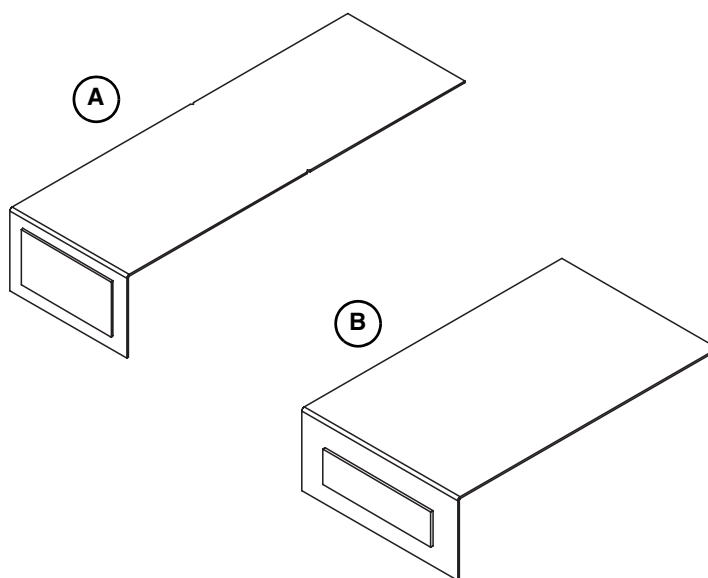

Tools Needed



- #2 Square-head Robertson driver

Installing the Kit



Turn off all power supplying this equipment before working inside the panelboard; follow all lockout/tagout procedures.

- 1 Remove the trim front and deadfront assembly. Retain all screws and the deadfront assembly for reuse.

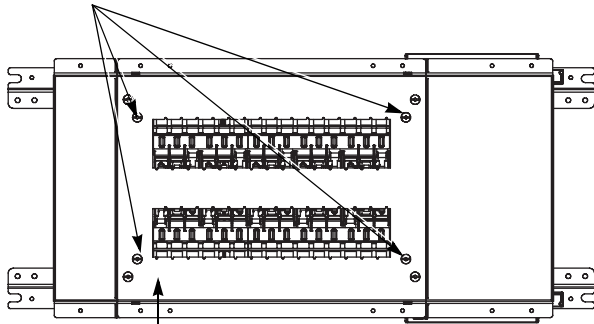

Deadfront assembly

NQODBFMB20 NQ Kit

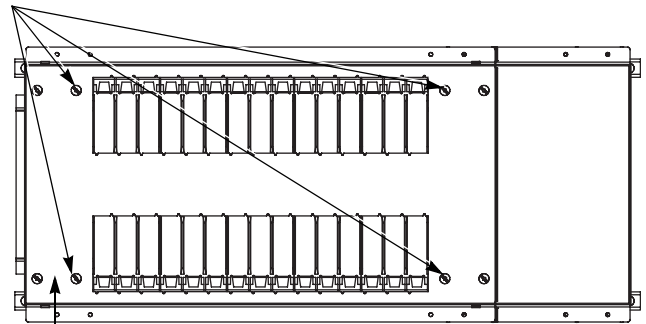

Deadfront assembly

NFBFMB20 NF Kit

- 2 Using a clean, dry cloth, clean the enclosure surface, adjacent to the backfed main circuit breaker. The surface must be free of dust, oil, and other contaminants.

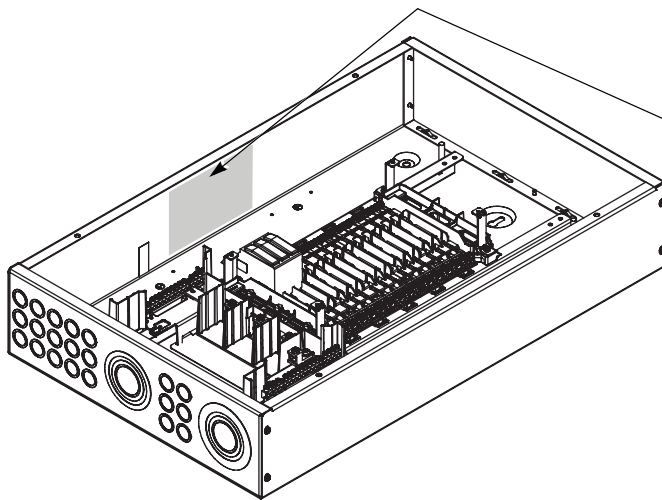

NQODBFMB20 NQ Kit

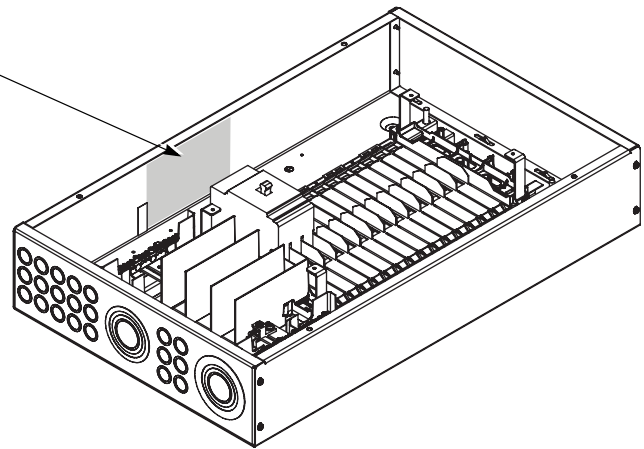

NFBFMB20 NF Kit

- 3** Remove the protective film from the adhesive backing on the backfed main circuit breaker barrier.

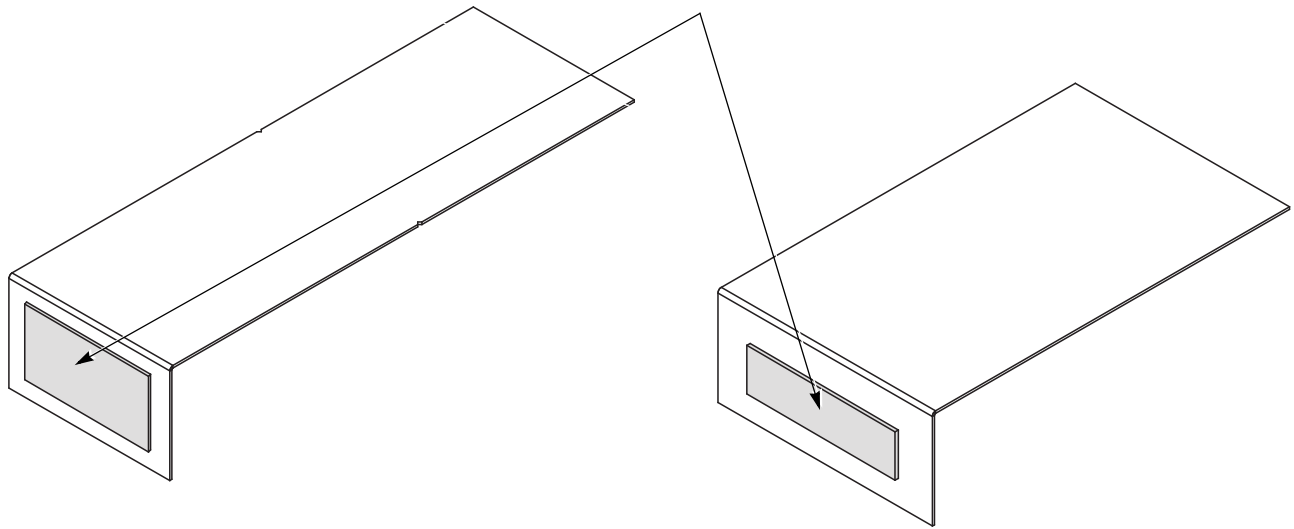

NQODBFMB20 NQ Kit

NFBFMB20 NF Kit

- 4** Ensure the backfed main circuit breaker barrier is placed overlapping the backfed main circuit breaker, as shown. Then, press the barrier onto the side of the enclosure.

NOTE: When using this barrier in a 14 in. (356 mm) NQ enclosure, cut off the excess barrier length at the notches.

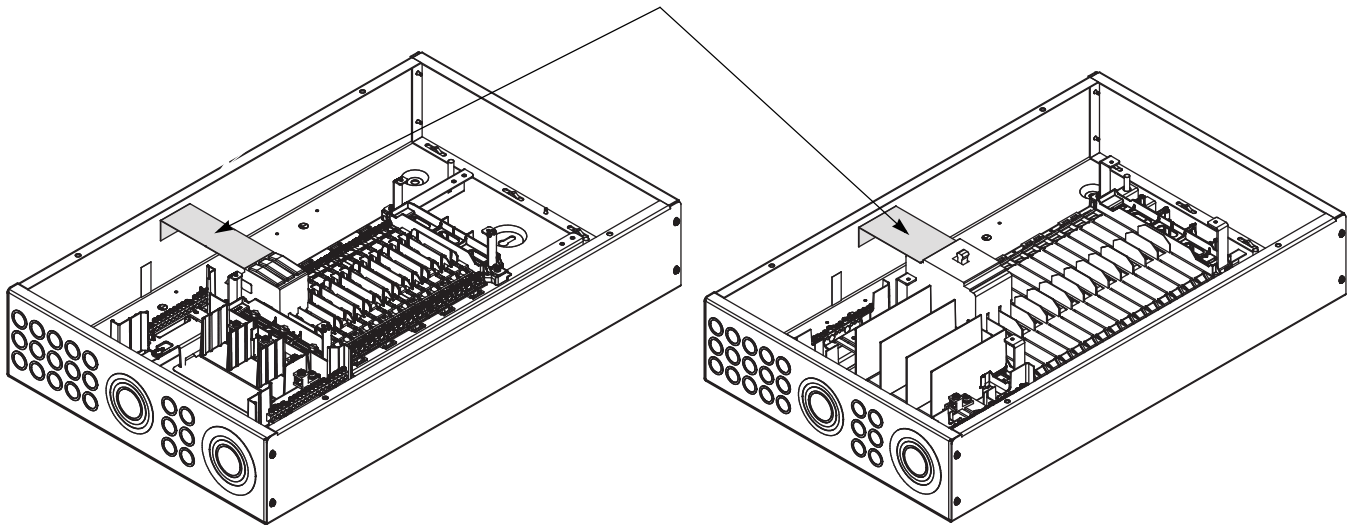

NQODBFMB20 NQ Kit

NFBFMB20 NF Kit

5 Remount the deadfront assembly and trim front using the screws retained in step 1.

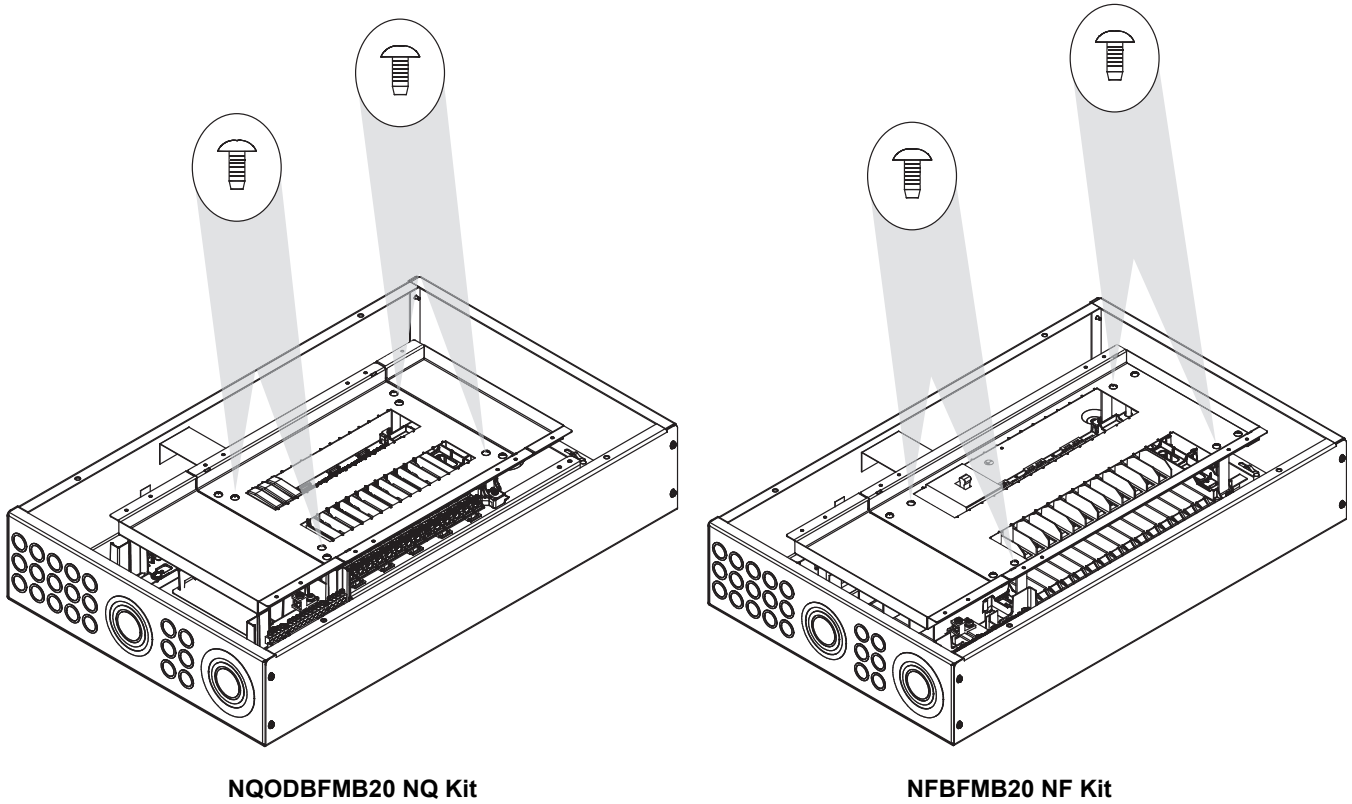

For technical support on the installation of this kit, contact the Square D/Schneider Electric Customer Information Center at 1-888-SquareD (1-888-778-2733).

Schneider Electric USA
252 North Tippecanoe
Peru, IN 46970 USA
1-888-SquareD (1-888-778-2733)
www.us.SquareD.com

Square D® is a trademark or registered trademark of Schneider Electric. Other trademarks used herein are the property of their respective owners.

Electrical equipment should be installed, operated, serviced, and maintained only by qualified personnel. No responsibility is assumed by Schneider Electric for any consequences arising out of the use of this material.



California Proposition 65 Warning—Nickel Compounds and Bisphenol A (BPA)

Advertencia de la Proposición 65 de California— compuestos de níquel y Bisfenol A (BPA)

Avertissement concernant la Proposition 65 de Californie— composés de nickel et Bisphénol A (BPA)

⚠️ WARNING: This product can expose you to chemicals including Nickel compounds, which are known to the State of California to cause cancer, and Bisphenol A (BPA), which is known to the State of California to cause birth defects or other reproductive harm. For more information go to www.P65Warnings.ca.gov.

⚠️ ADVERTENCIA: Este producto puede exponerle a químicos incluyendo compuestos de níquel, que son conocidos por el Estado de California como causantes de cáncer, y Bisfenol A (BPA), que es conocido por el Estado de California como causante de defectos de nacimiento u otros daños reproductivos. Para mayor información, visite www.P65Warnings.ca.gov.

⚠️ AVERTISSEMENT: Ce produit peut vous exposer à des agents chimiques, y compris composés de nickel, identifiés par l'État de Californie comme pouvant causer le cancer, et Bisphénol A (BPA) reconnus par l'État de Californie comme pouvant causer des malformations congénitales ou autres troubles de l'appareil reproducteur. Pour de plus amples informations, prière de consulter www.P65Warnings.ca.gov.

All trademarks are the property of Schneider Electric SE, its subsidiaries, and affiliated companies.

Schneider Electric USA, Inc.
800 Federal Street
Andover, MA 01810 USA
888-778-2733
www.schneider-electric.us

Todas las marcas comerciales son propiedad de Schneider Electric SE, sus filiales y compañías afiliadas.

Importado en México por:
Schneider Electric México, S.A. de C.V.
Av. Ejercito Nacional No. 904
Col. Palmas, Polanco 11560 México, D.F.
55-5804-5000
www.schneider-electric.com.mx

Toutes les marques commerciales sont la propriété de Schneider Electric SE, ses filiales et compagnies affiliées.

Schneider Electric Canada, Inc.
5985 McLaughlin Road
Mississauga, ON L5R 1B8 Canada
800-565-6699
www.schneider-electric.ca