

ASSEMBLY INSTRUCTIONS

INSTRUCTIONS DE MONTAGE • INSTRUCCIONES DE ENSAMBLAJE

TOOLS REQUIRED: Phillips Screwdriver; Hammer or Mallet

PRODUCT WARRANTY REGISTRATION is available online at: www.safcoproducts.com

• **OUTILS REQUIS :** tournevis à pointe cruciforme; marteau ou maillet
• **L'INSCRIPTION POUR LA GARANTIE DU PRODUIT** est disponible sur l'Internet : www.safcoproducts.com

• **HERRAMIENTAS REQUERIDAS:** Destornillador Phillips®; martillo o mazo
• **EI REGISTRO PARA LA GARANTÍA DEL PRODUCTO** está disponible en la Internet: www.safcoproducts.com

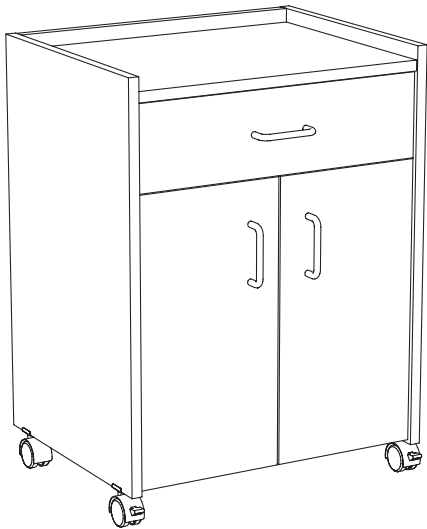



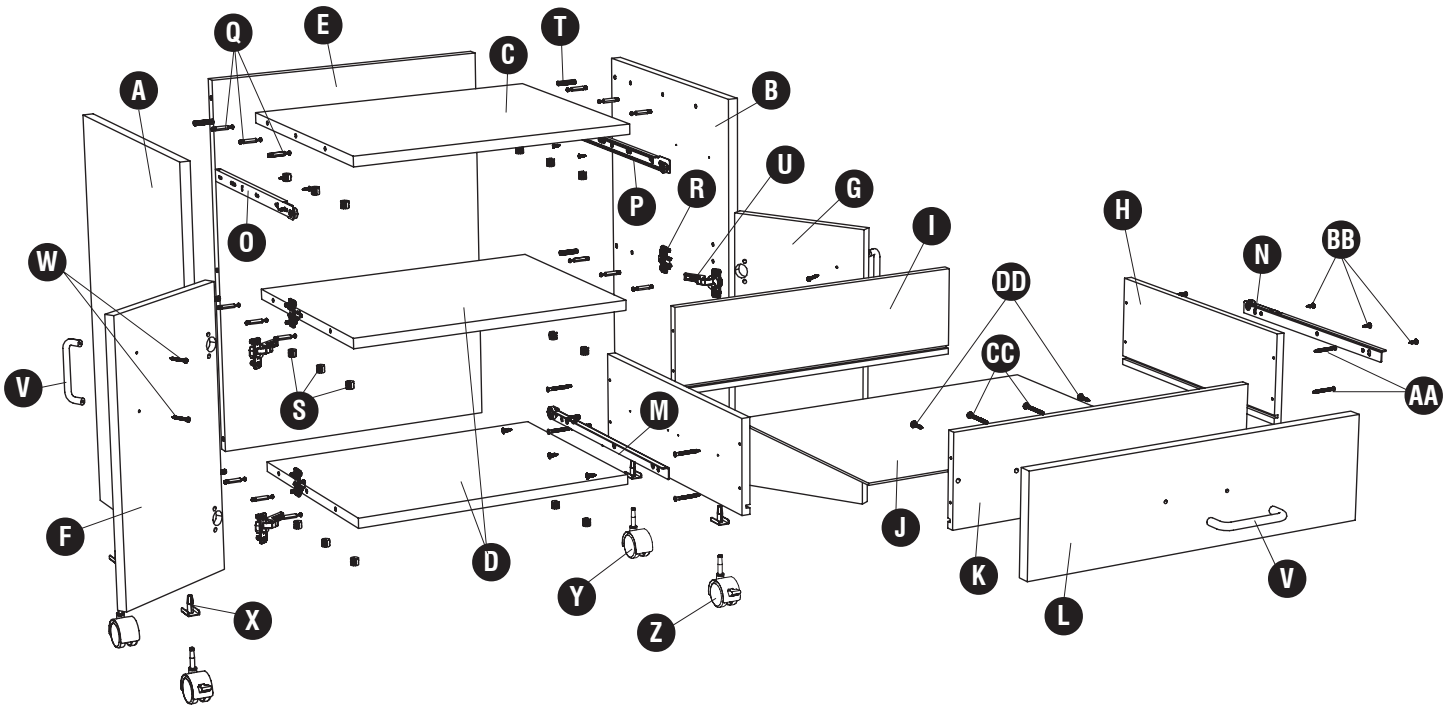



PARTS LIST / LISTE DES PIÈCES / LISTA DE PIEZAS			
CODE / CODIGO	DESCRIPTION / DESCRIPTION / DESCRIPCIÓN	QTY. / QUANTITÉ / CANTIDAD	PART NO. / N° DE PIECE / NO. DE PIEZA
(A)	Left Side Panel / Panneau latéral gauche / Panel lateral izquierdo	1	8954-02GR
(B)	Right Side Panel / Panneau latéral droit / Panel lateral derecho	1	8954-03GR
(C)	Top Panel / Panneau supérieur / Panel superior	1	8953-04GR
(D)	Shelf Panel / Panneau du Étagère / Panel Estante	2	8953-05GR
(E)	Back Panel / Panneau arrière / Panel trasero	1	8953-01GR
(F)	Left Door / Panneau de la Porte gauche / Panel de puerta izquierdo	1	8954-08GR
(G)	Right Door / Panneau de la Porte droit / Panel de puerta derecho	1	8954-09GR
(H)	Drawer Side / Coté du tiroir / Lateral del cajón	2	8954-20BL
(I)	Drawer Back / Arrière du tiroir / Parte trasera del cajón	1	8954-13BL
(J)	Drawer Bottom / Fond du tiroir / Parte inferior del cajón	1	8954-22NC
(K)	Inner Drawer Front / Intérieur avant du tiroir / Parte delantera interna del cajón	1	8954-12BL
(L)	Outer Drawer Front / Extérieur avant du tiroir / Parte delantera exterior del cajón	1	8954-11GR
(M)	Left Drawer Rail / Rail gauche du tiroir / Barra izquierda del cajón	1	8954-17BL
(N)	Right Drawer Rail / Rail droit du tiroir / Barra derecha del cajón	1	8954-18BL
(O)	Left Cabinet Rail / Rail gauche du meuble / Barra izquierda del gabinete	1	8954-15BL
(P)	Right Cabinet Rail / Rail droit du meuble / Barra derecha del gabinete	1	8954-16BL

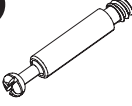
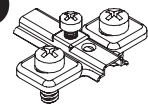
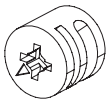
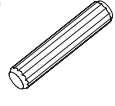
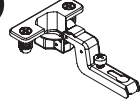
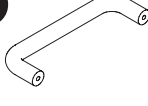

L'Assistance téléphonique à la clientèle Safco au 1-800-664-0042
de 8H00 à 16H30 (Heure centrale) (Opérateurs de langue anglaise)

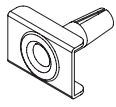
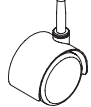
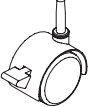
Línea directa para el cliente de Safco 1-800-664-0042
de 8:00 AM a 4:30 PM (Hora Central) (Operadores que hablan inglés)

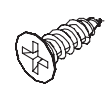
HARDWARE PACK / PAQUET MATÉRIEL / PAQUETE MATERIAL
8954-19GR

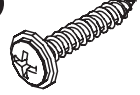
<p>Q</p>  <p>Screw Post <i>Tige-vis</i> Poste con tornillo en extremo Qty. / Qte. / Cant.: 18 #HFFMFB</p>	<p>R</p>  <p>Hinge Mount <i>Support de la charnière</i> Apoyo de la charnela Qty. / Qte. / Cant.: 4 #8919-14</p>	<p>S</p>  <p>Cam <i>Came</i> Leva Qty. / Qte. / Cant.: 18 #HFFMFC</p>	<p>T</p>  <p>Wood Dowel <i>Piquet de bois</i> Clavijas de madera Qty. / Qte. / Cant.: 6 #8918-30</p>	<p>U</p>  <p>Hinge <i>Charnière</i> Charnela Qty. / Qte. / Cant.: 4 #8919-16</p>	<p>V</p>  <p>Handle <i>Vis</i> Manche Qty. / Qte. / Cant.: 3 #8953-31GR</p>	<p>W</p>  <p>Screw #8 x 1 1/4" <i>Vis de #8 x 3,2 cm</i> Tornillo de #8 x 1 1/4 pulg. Qty. / Qte. / Cant.: 4 #8953-27</p>
<p>X</p>  <p>Caster Bracket <i>Support de roulette</i> Soporte de las ruedas Qty. / Qte. / Cant.: 4 #8953-10</p>	<p>Y</p>  <p>Non-Locking Caster <i>Roulette sans frein</i> Rueda sin freno Qty. / Qte. / Cant.: 2 #8953-25</p>	<p>Z</p>  <p>Locking Caster <i>Roulette avec frein</i> Rueda con freno Qty. / Qte. / Cant.: 2 #8953-24</p>	<p>AA</p>  <p>Drawer Screw <i>Vis de tiroir</i> Tornillo del cajón Qty. / Qte. / Cant.: 8 #8962-27</p>	<p>BB</p>  <p>1/2" Flat-Head Screw <i>Vis à fente droite de 1,3 cm</i> Tornillo de cabeza plana 1/2 pulg. Qty. / Qte. / Cant.: 12 #3695-28</p>	<p>CC</p>  <p>Screw #8 x 1 3/4" <i>Vis de #8 x 4,4 cm</i> Tornillo de #8 x 1 3/4 pulg. Qty. / Qte. / Cant.: 2 #8954-26NC</p>	<p>DD</p>  <p>7/8" Washer Head Screw <i>Vis à rondelle de 2,2 cm</i> Tornillo con cabeza roldana 7/8 pulg. Qty. / Qte. / Cant.: 2 #1910-23</p>

Properly identify the four types of rails used!

The Drawer Rails (M, N) have L-shaped cross-sections; rollers are at the BACK.

The Cabinet Rails (O, P) have C-shaped cross-sections; rollers are at the FRONT.

S'assurer de distinguer les quatre rails fournis!

Les rails du tiroir (M et N) présentent un profil en « L », et leur roulette est à l'ARRIÈRE.

Les rails du meuble (O et P) présentent un profil en « C », et leur roulette est à l'AVANT.

Identifique correctamente los cuatro tipos de barras que se usan!

Las barras del cajón (M, N) tienen secciones transversales en forma de L. Los rodillos están en la parte TRASERA.

Las barras del gabinete (O, P) tienen secciones transversales en forma de C. Los rodillos están en la parte DELANTERA.

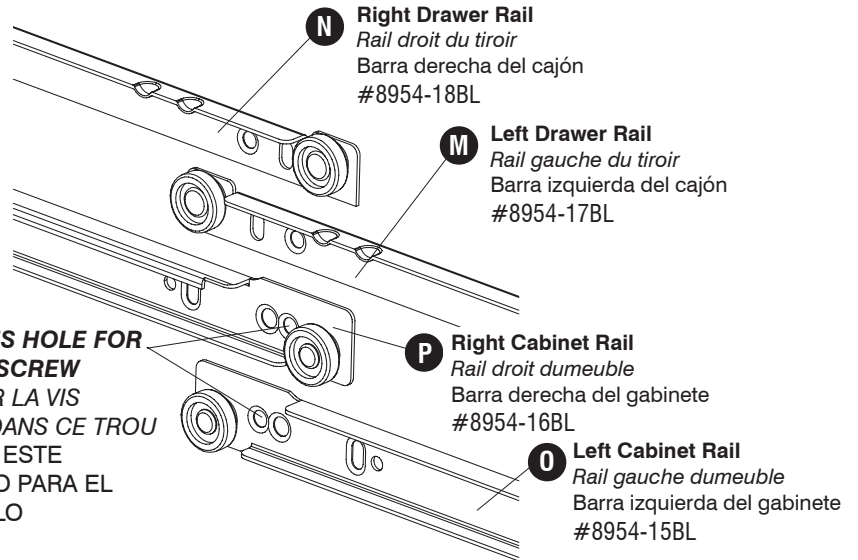

1

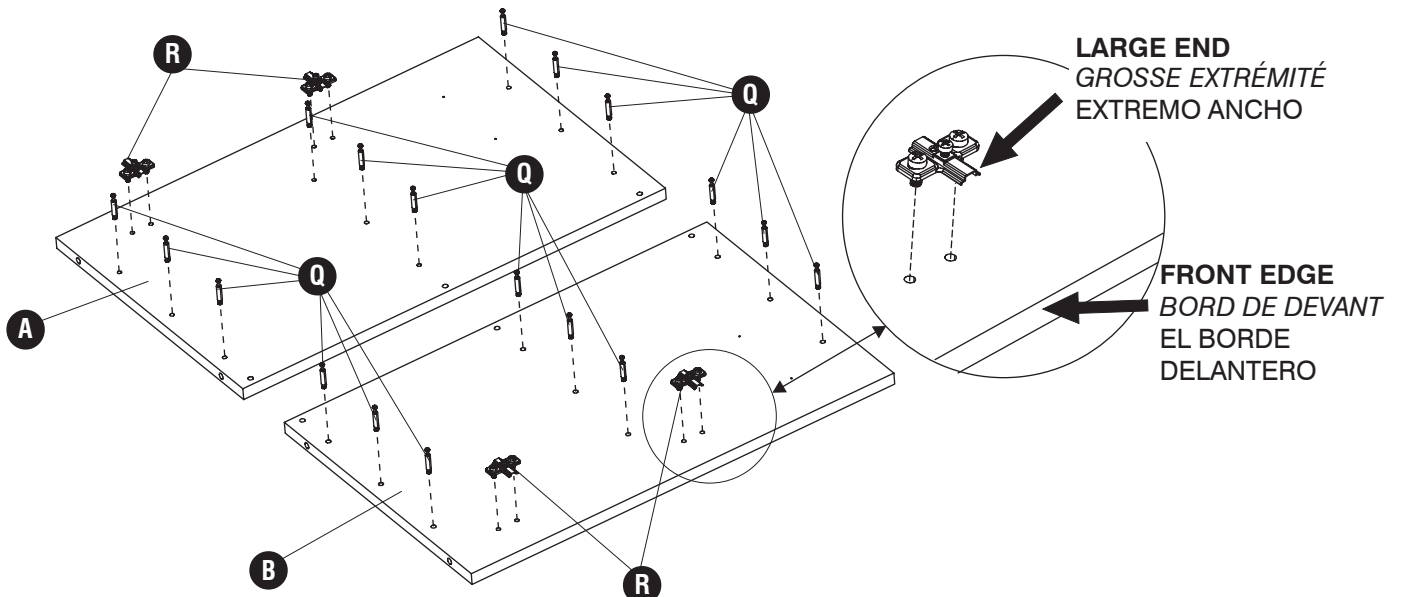

2

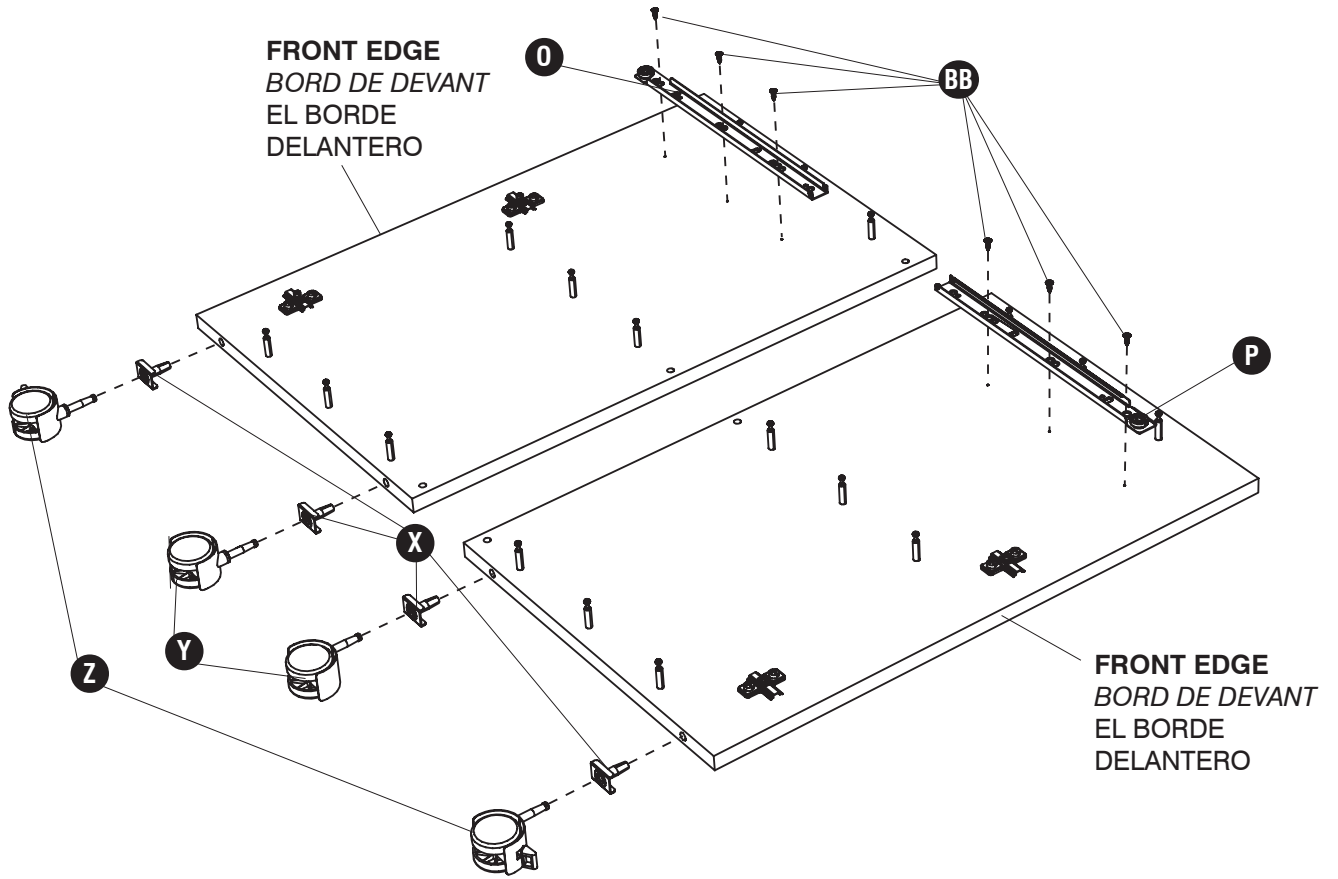

3

ARROW POINTS TO EDGE
LE FLÉCHE POUR POINTER
VERS BORD
LA FLECHA PARA APUNTAR
HACIA EL BORDE

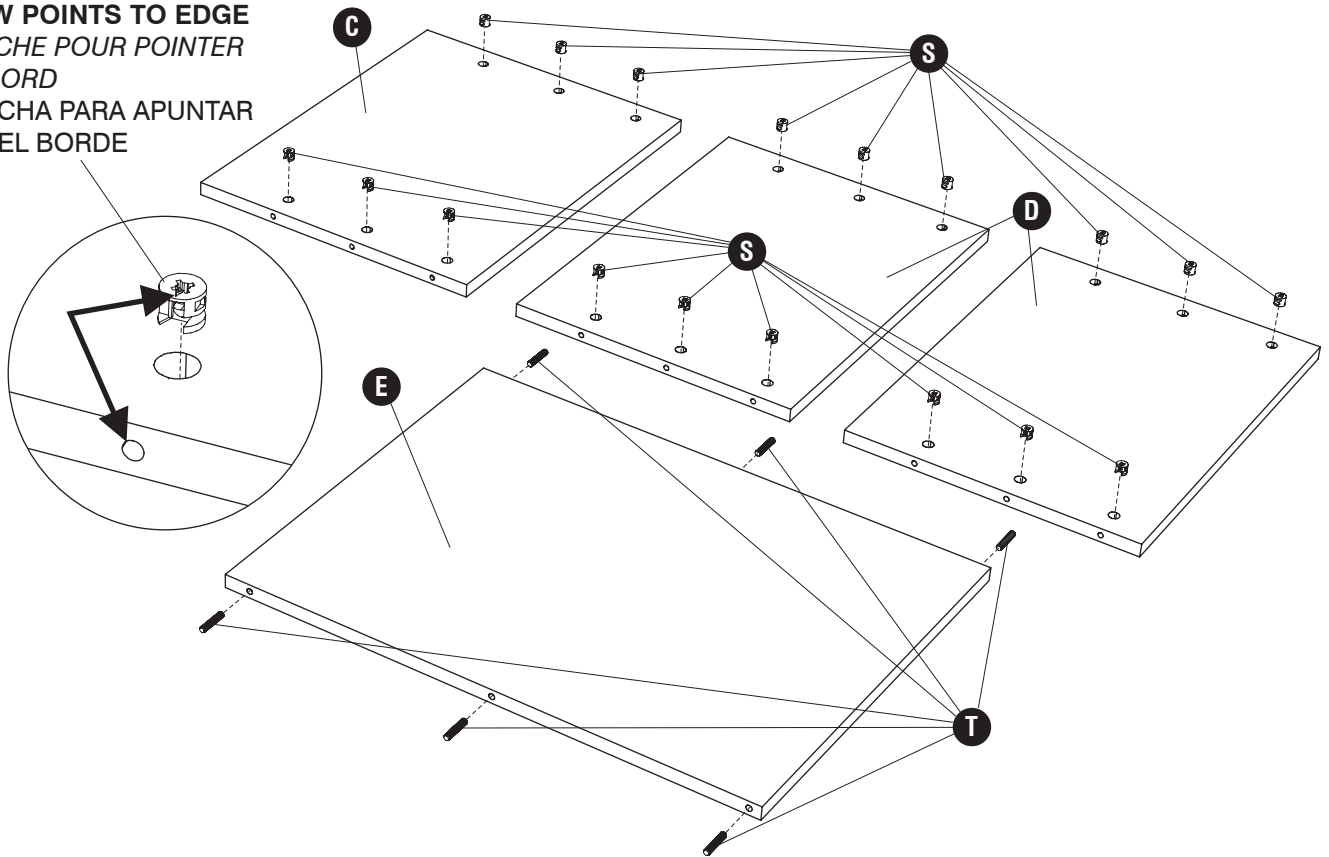

4

HAMMER OR MALLET
MARTEAU OU MAILLET
MARTILLO O MAZO

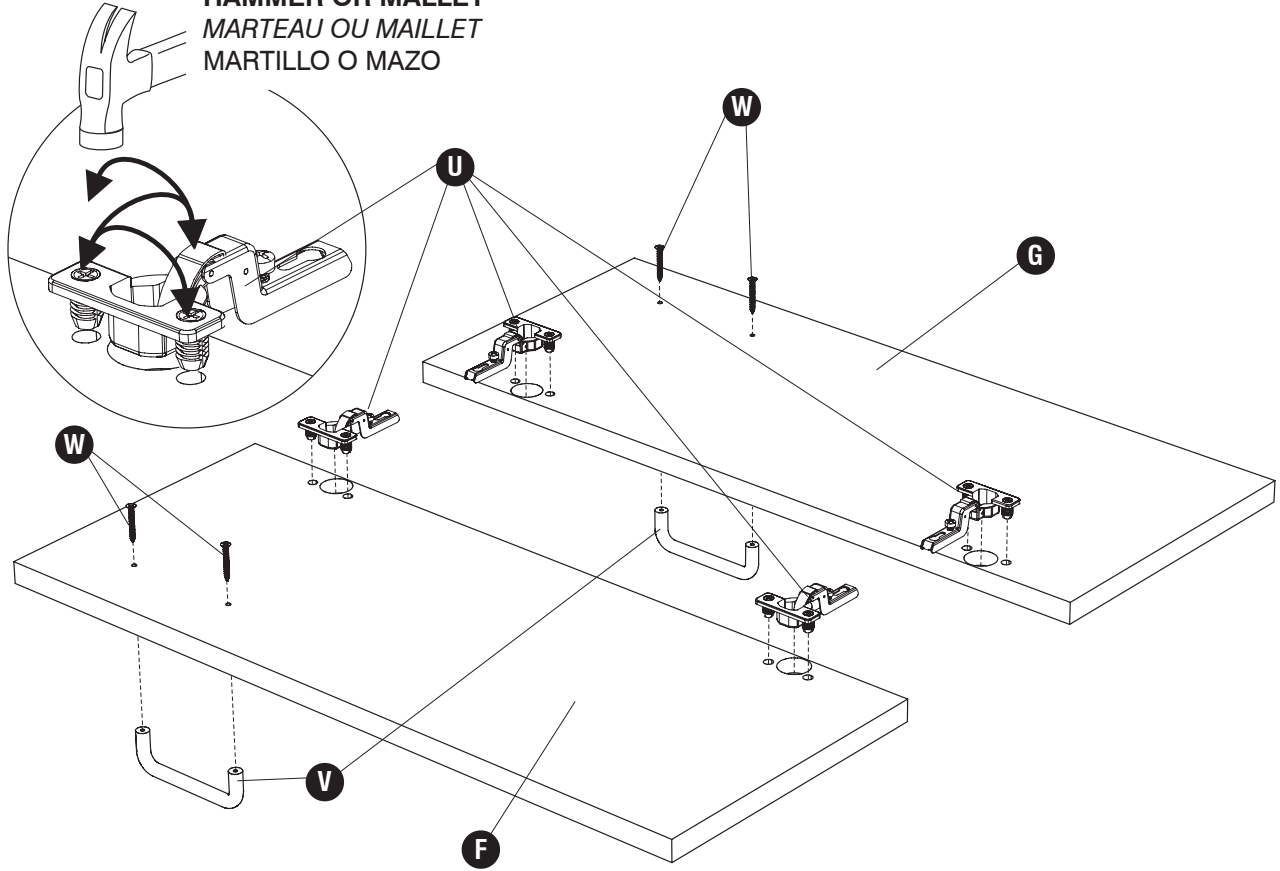

5

FINISHED EDGES
BORDS FINIS
LOS BORDES
ACABADOS

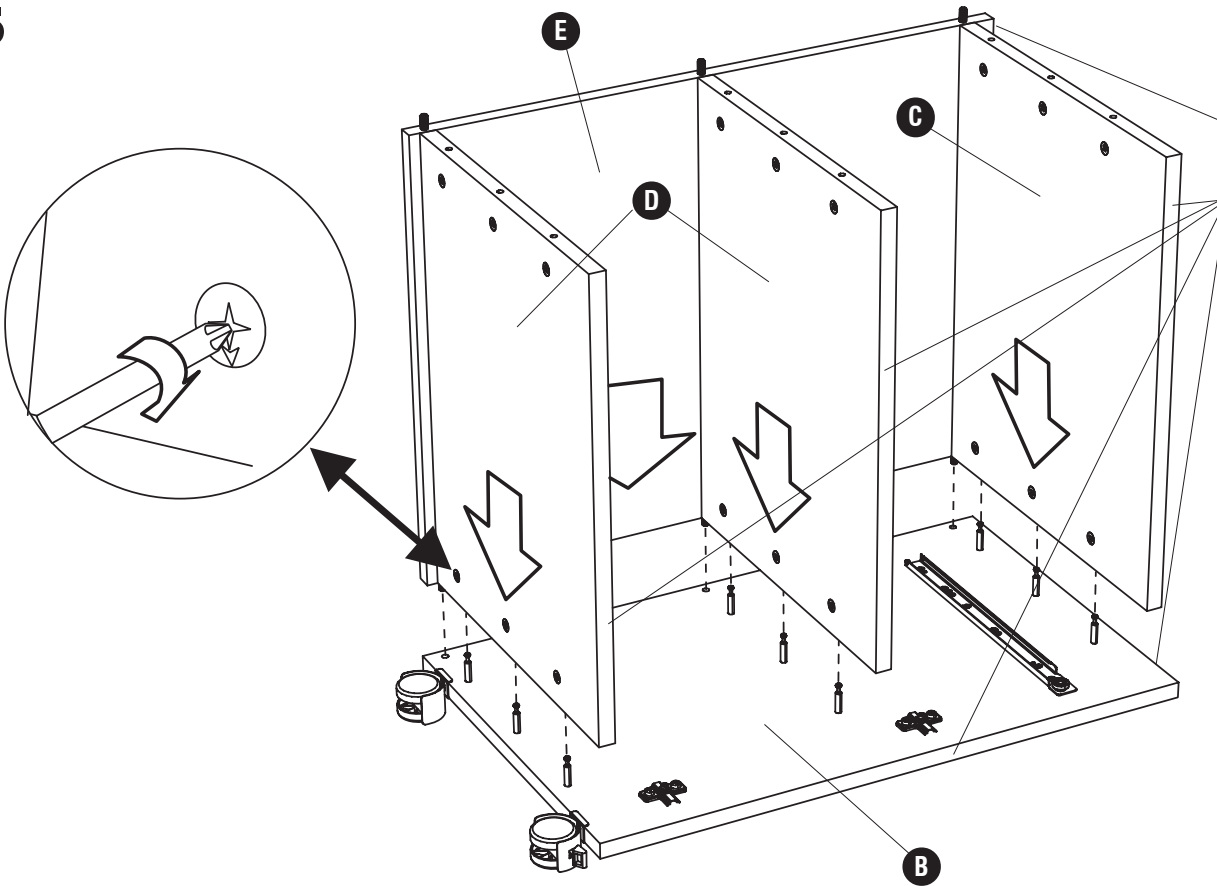

6

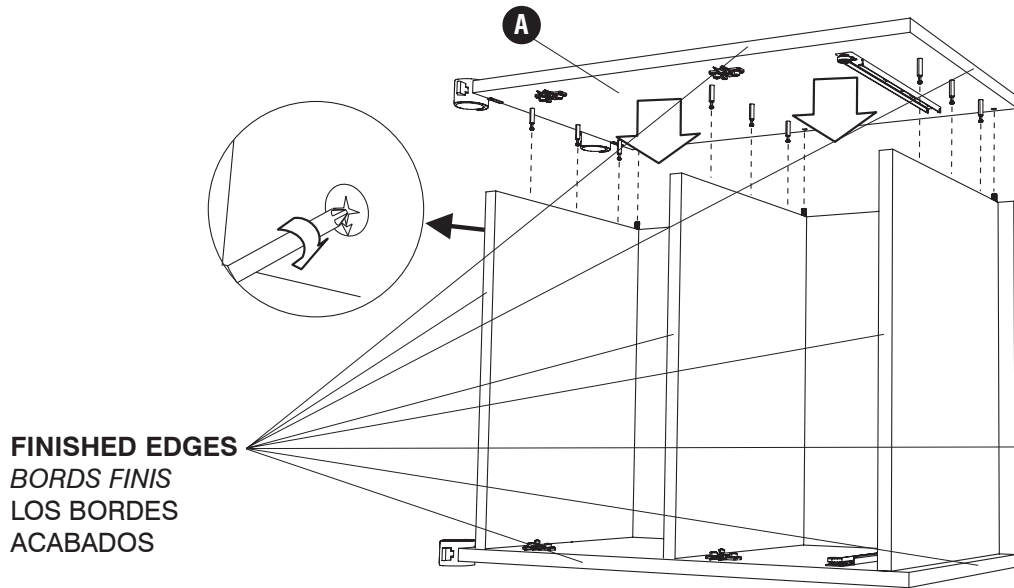

7

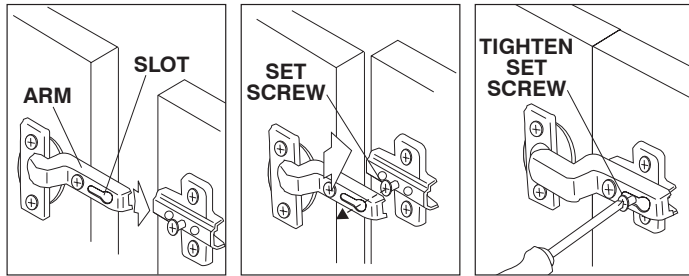

Français :

LE
BRAS

LA
FENTE

Le vis
d'arrêt

Serrer le
vis d'arrêt

Española:

BRAZO

RANURA

TORNILLOS
DE SUJECIÓN

APRETE LOS
TORNILLOS
DE SUJECIÓN

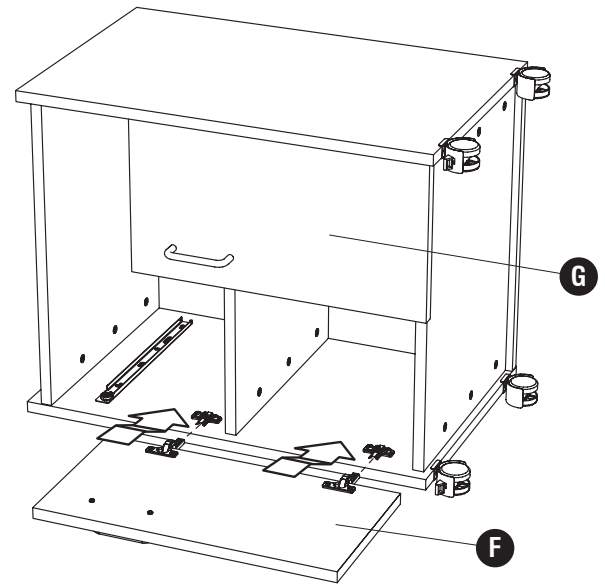

8

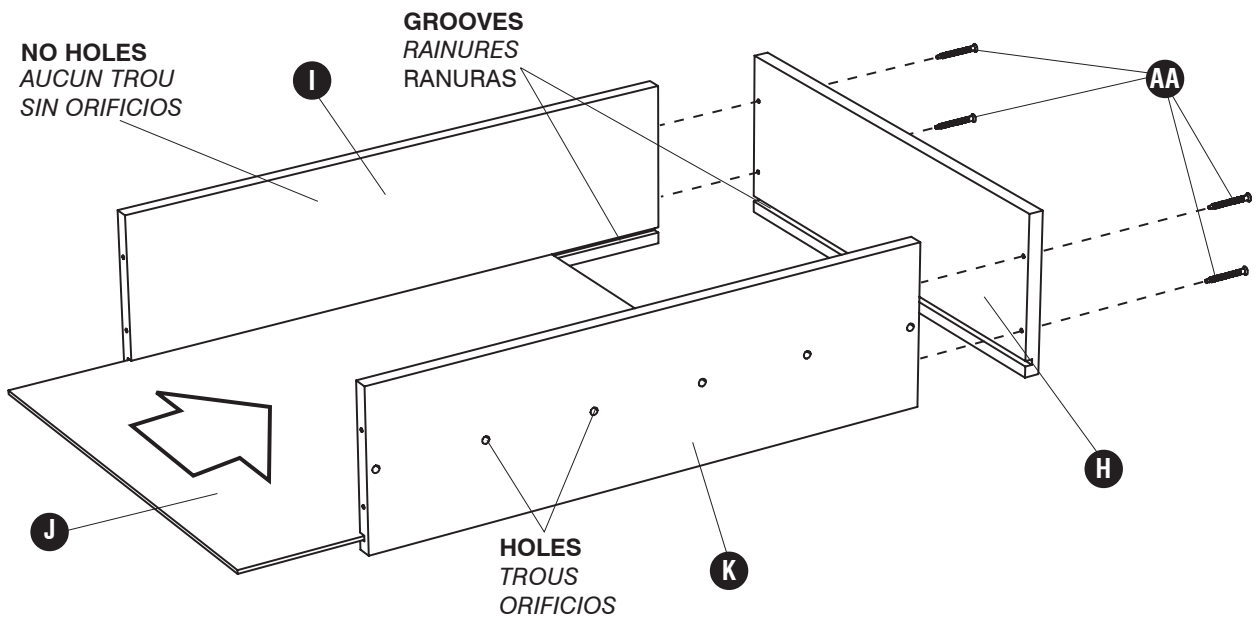

9

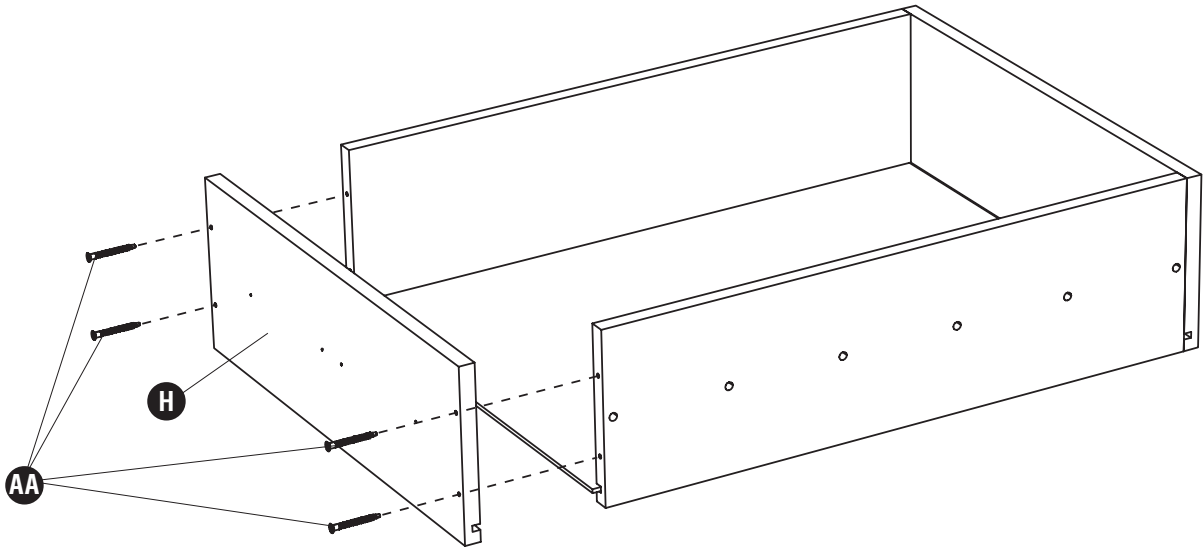

10

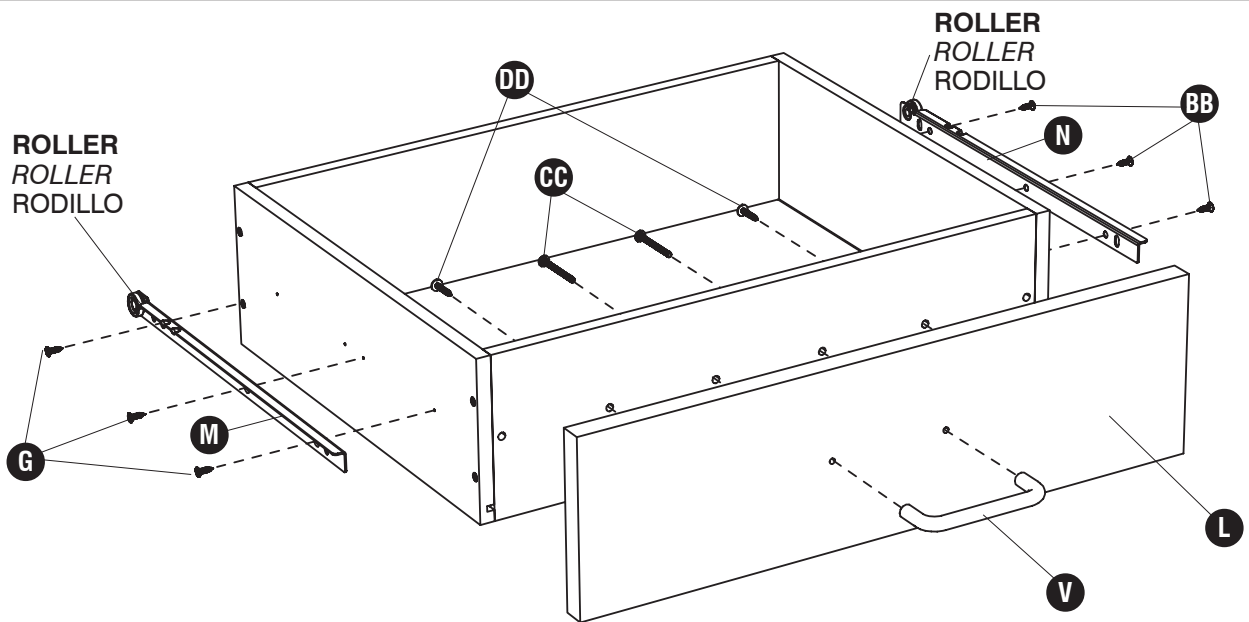

11

Install the drawer: lift the back rollers on the Drawer Rails over the front rollers on the Cabinet Rails, tilt the drawer enough to start the drawer moving, and lower the drawer to push it all the way into place.

Installer le tiroir: passer les roulettes arrière des rails du tiroir au-dessus des roulettes avant de ceux du meuble; incliner suffisamment le tiroir pour qu'il commence à glisser, en l'abaissant ensuite pour l'insérer complètement.

Instalación del cajón: levante los rodillos traseros en las barras del cajón sobre los rodillos delanteros de las barras del gabinete. Inclina el cajón lo suficiente para que se empiece a mover y baje el cajón para poder empujarlo totalmente en su posición.

