

100 and 225 A Sub-Feed Lug Kit Installation onto an NQ Panelboard



**Instalación de un accesorio de
zapatas de subalimentación de 100 y
225 A en un tablero de alumbrado NQ**

**Installation du kit de cosses de sous-
alimentation de 100 et 225 A dans un
panneau de distribution NQ**

Instruction Bulletin
Boletín de instrucciones
Directives d'utilisation

80043-729-01

Retain for Future Use.
Conservar para uso futuro.
À conserver pour usage ultérieur.

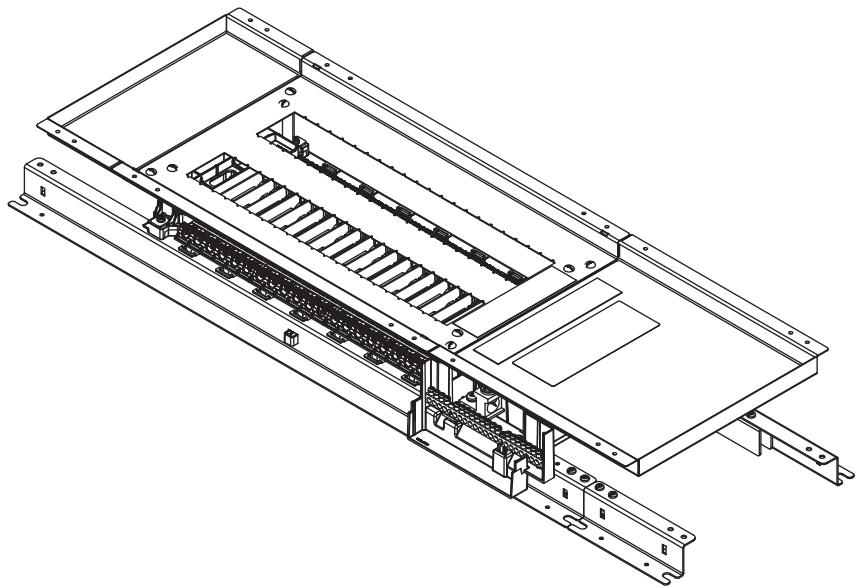

Instruction Bulletin

100 and 225 A Sub-Feed Lug Kit Installation onto an NQ Panelboard

Class 1640

Retain for future use.

Introduction

This bulletin contains instructions for installing a Square D® brand 100 A or 225 A sub-feed lug kit onto a Square D brand NQ panelboard manufactured by Schneider Electric.

ENGLISH

Safety Precautions

⚠ DANGER

HAZARD OF ELECTRIC SHOCK, EXPLOSION, OR ARC FLASH

- Apply appropriate personal protective equipment (PPE) and follow safe electrical work practices. See NFPA 70E.
- This equipment must only be installed and serviced by qualified electrical personnel.
- Turn off all power supplying this equipment before working on or inside equipment.
- Always use a properly rated voltage sensing device to confirm power is off.
- Replace all devices, doors and covers before turning on power to this equipment.

Failure to follow these instructions will result in death or serious injury.

Kit Contents

NQSFL1 and NQSFL2

- A. Neutral lug (1)
- B. **NQSFL1 kit only**—100 A Line lugs (3)
- C. **NQSFL2 kit only**—225 A Line lugs (3)
- D. **NQSFL2 kit only**—10-32 x 5/16-inch tapping screws (8)
- E. 1/4-20 x 9/16-inch tapping screw (1)
- F. 1/4-20 x 7/8-inch tapping screws (6)
- G. **NQSFL2 kit only**—Rail extensions (2)
- H. **NQSFL2 kit only**—Rail splices (2)
- I. **NQSFL2 kit only**—Main lug cover (1)
- J. **NQSFL2 kit only**—Lug barriers (2)

NOTE: Screws enlarged to show detail.

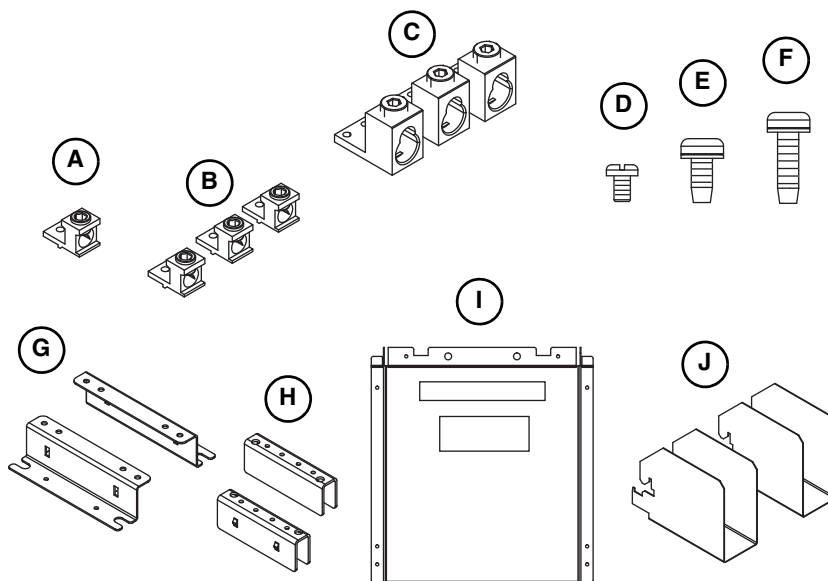

Tools Needed



- #2 Square-head Robertson driver
- Torque wrench with 5/32-inch Allen driver (for 100 A kit)
- Torque wrench with 3/8-inch Allen driver (for 225 A kit)

Installing the Sub-Feed Lug Kit



Turn off all power supplying this equipment before working inside the panelboard; follow all lockout/tagout procedures.

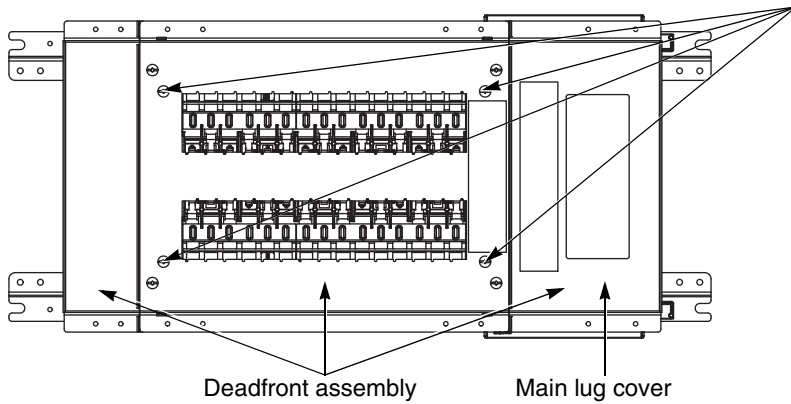

1 Remove the deadfront assembly. Retain the four screws for reuse.

2 Remove the line lugs from the panel bus. For **100 A** panel applications, retain the lugs for reuse and discard the screws. For **225 A** panel applications, discard the lugs and screws.

3 For **225 A**, assemble the plastic lug barriers included in the kit into the end support, one on "A" phase and one on "C" phase.

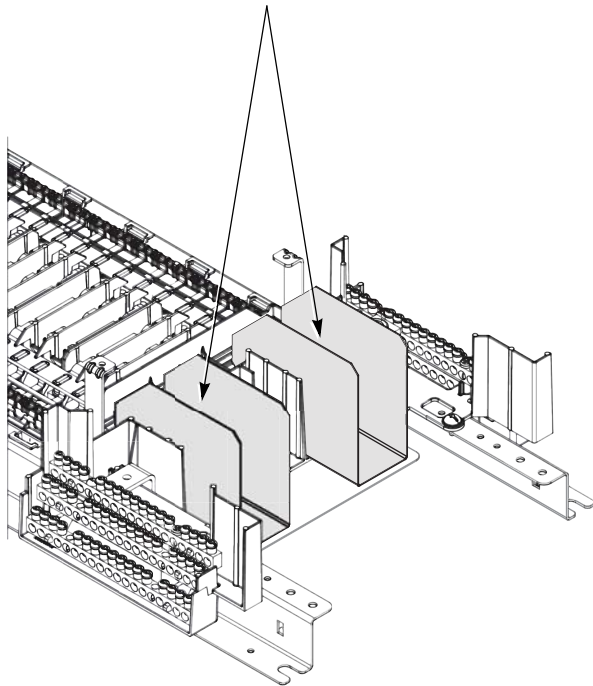

Barrier Rotates into Place

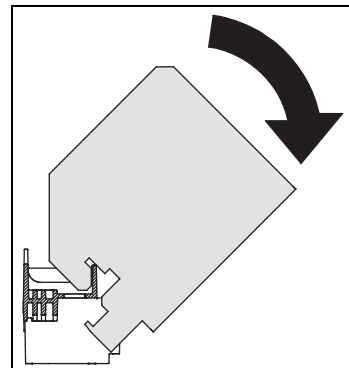

Barrier Installed

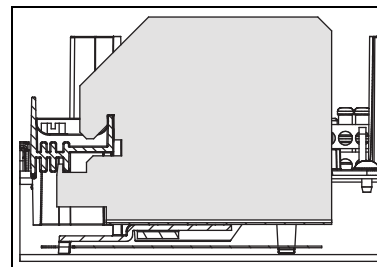

NOTE: For step 4 and step 5, do not overtighten the screws.

- 4** Install the line lugs included in the kit on the panel bus using the 1/4-20 x 7/8-inch tapping screws included in the kit. For **100 A**, add the lugs retained from step 2 (refer to 100 A graphic below) using the screws included in the kit. Tighten to 25–30 lb-in (2.8–3.4 N•m).

NOTE: Middle lug is installed for three-phase panels only.

- 5** Install the neutral lug included in the kit to the neutral bar using one 1/4-20 x 9/16-inch tapping screw included in the kit. Tighten to 25–30 lb-in (2.8–3.4 N•m).

100 A Lugs Installed

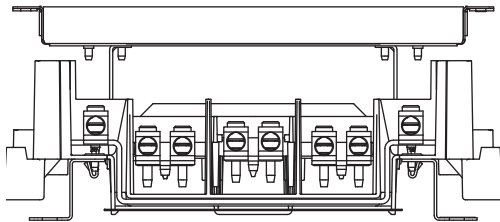

225 A Lugs Installed

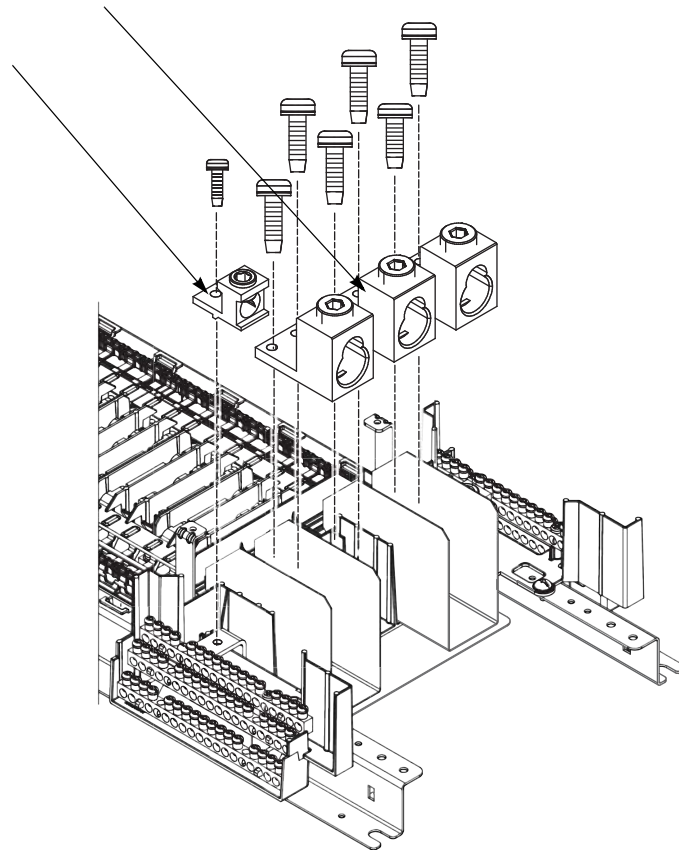
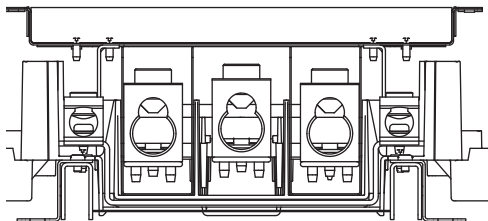

- 6 Additional step for a 225 A panelboard:**

Install the rail extensions to the end of the existing mounting rail using rail splices and eight 10-32 x 5/16-inch tapping screws included in the kit.

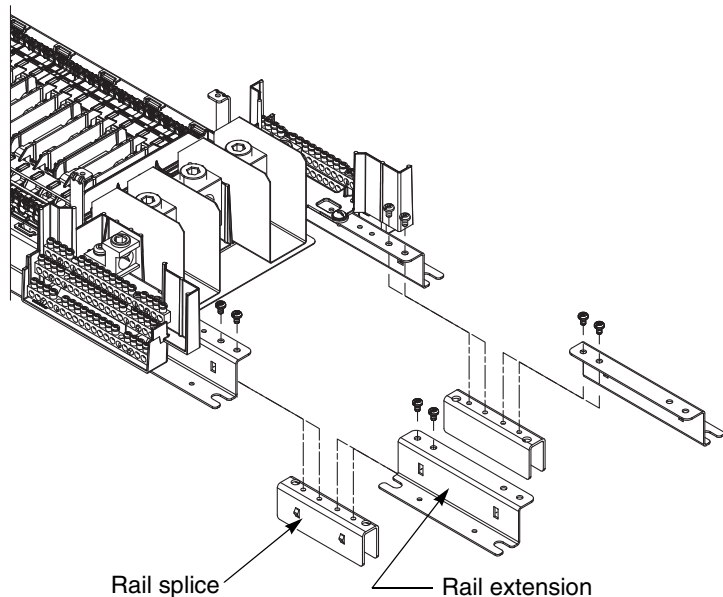

7 Additional step for a 225 A panelboard:

Remove the existing main lug cover (see step 1) and discard, but retain the two screws. Mount the main lug cover included in the kit using the two retained screws.

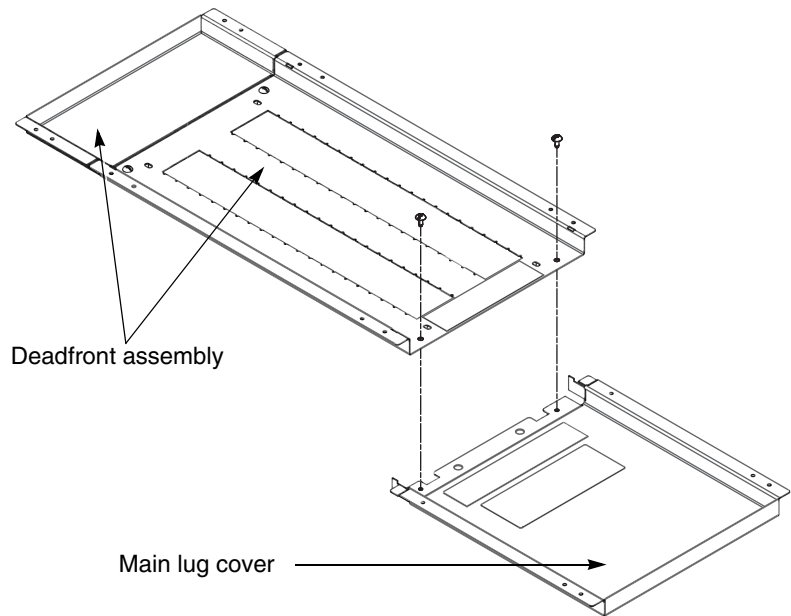

8 Remount the deadfront assembly using the screws retained from step 1.

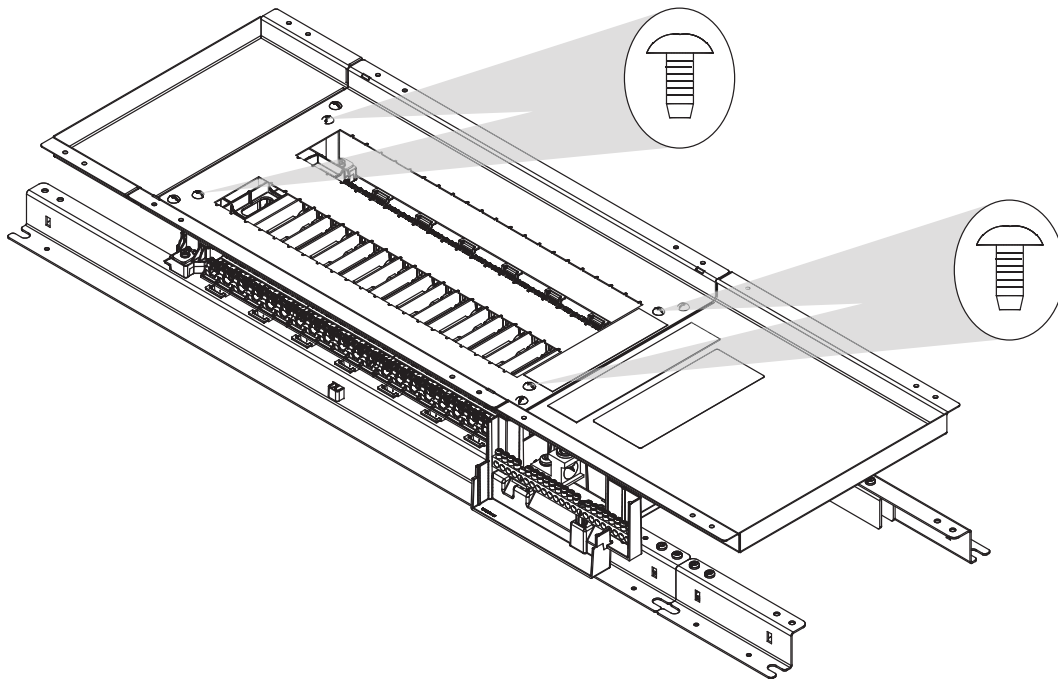

For technical support on the installation of this kit, contact the Square D/Schneider Electric Customer Information Center at 1-888-SquareD (1-888-778-2733).

Schneider Electric USA
252 North Tippecanoe
Peru, IN 46970 USA
1-888-SquareD (1-888-778-2733)
www.us.SquareD.com

Electrical equipment should be installed, operated, serviced, and maintained only by qualified personnel. No responsibility is assumed by Schneider Electric for any consequences arising out of the use of this material.

© 2008 Schneider Electric All Rights Reserved



California Proposition 65 Warning—Nickel Compounds and Bisphenol A (BPA)

Advertencia de la Proposición 65 de California— compuestos de níquel y Bisfenol A (BPA)

Avertissement concernant la Proposition 65 de Californie— composés de nickel et Bisphénol A (BPA)

⚠ WARNING: This product can expose you to chemicals including Nickel compounds, which are known to the State of California to cause cancer, and Bisphenol A (BPA), which is known to the State of California to cause birth defects or other reproductive harm. For more information go to www.P65Warnings.ca.gov.

⚠ ADVERTENCIA: Este producto puede exponerle a químicos incluyendo compuestos de níquel, que son conocidos por el Estado de California como causantes de cáncer, y Bisfenol A (BPA), que es conocido por el Estado de California como causante de defectos de nacimiento u otros daños reproductivos. Para mayor información, visite www.P65Warnings.ca.gov.

⚠ AVERTISSEMENT: Ce produit peut vous exposer à des agents chimiques, y compris composés de nickel, identifiés par l'État de Californie comme pouvant causer le cancer, et Bisphénol A (BPA) reconnu par l'État de Californie comme pouvant causer des malformations congénitales ou autres troubles de l'appareil reproducteur. Pour de plus amples informations, prière de consulter www.P65Warnings.ca.gov.

All trademarks are the property of Schneider Electric SE, its subsidiaries, and affiliated companies.

Schneider Electric USA, Inc.
800 Federal Street
Andover, MA 01810 USA
888-778-2733
www.schneider-electric.us

Todas las marcas comerciales son propiedad de Schneider Electric SE, sus filiales y compañías afiliadas.

Importado en México por:
Schneider Electric México, S.A. de C.V.
Av. Ejercito Nacional No. 904
Col. Palmas, Polanco 11560 México, D.F.
55-5804-5000
www.schneider-electric.com.mx

Toutes les marques commerciales sont la propriété de Schneider Electric SE, ses filiales et compagnies affiliées.

Schneider Electric Canada, Inc.
5985 McLaughlin Road
Mississauga, ON L5R 1B8 Canada
800-565-6699
www.schneider-electric.ca