



# DIVAR IP 6000 (3U)

DIP-61F0-00N | DIP-61F3-16HD | DIP-61F4-16HD



**BOSCH**

en Installation Manual



## Table of contents

<b>1</b>	<b>Safety information</b>	<b>5</b>
1.1	Safety message explanation	5
1.2	Safety precautions	5
1.3	Important safety instructions	6
1.4	Electrical safety precautions	8
1.5	ESD precautions	9
1.6	Operating precautions	9
1.7	Notices	9
1.8	FCC and ICES compliance	10
<b>2</b>	<b>About this manual</b>	<b>12</b>
<b>3</b>	<b>System overview</b>	<b>13</b>
3.1	Chassis features	13
3.2	Chassis components	13
3.2.1	Chassis	13
3.2.2	Fans	13
3.2.3	Power supply	13
3.2.4	Air shroud	13
3.2.5	Mounting rails	13
3.3	System interface	14
3.3.1	Control panel buttons	15
3.3.2	Control panel LEDs	15
3.3.3	Drive carrier LEDs	16
3.3.4	Power supply LEDs	16
<b>4</b>	<b>Rack installation</b>	<b>18</b>
4.1	Unpacking the system	18
4.2	Preparing for setup	18
4.2.1	Choosing a setup location	18
4.2.2	Rack precautions	18
4.2.3	General system precautions	19
4.2.4	Rack mounting considerations	19
4.3	Rack mounting instructions	19
4.3.1	Identifying the sections of the rack rails	20
4.3.2	Separating the sections of the rack rails	20
4.3.3	Installing the inner rails on the chassis	21
4.3.4	Installing the outer rails to the rack	21
4.3.5	Installing the chassis in the rack	22
4.3.6	Installing the chassis in a Telco rack	23
4.4	Turning on the system	24
<b>5</b>	<b>System Setup – first Steps</b>	<b>25</b>
5.1	Introduction	25
5.2	Setup instruction	25
5.3	Setting the IP address	25
5.4	Standard system configuration	26
<b>6</b>	<b>RAID setup</b>	<b>27</b>
<b>7</b>	<b>Additional software and documentation</b>	<b>28</b>
<b>8</b>	<b>OSS licenses</b>	<b>29</b>
8.1	MIT - iniparser	29
8.2	MS-PL - MSDN Library	29

---

8.3	NTP License - NTP Project	30
<b>9</b>	<b>Maintenance</b>	<b>31</b>
9.1	Replacement components	31
9.2	Removing power from the system	31
9.3	Removing the chassis cover	32
9.4	Installing a SATA hard drive	32
9.4.1	Removing a hard drive from the chassis	32
9.4.2	Installing a hard drive into a hard drive carrier	33
9.4.3	Installing a hard drive into a front drive bay	35
9.5	Identifying a faulty SSD drive	35
9.6	Installing a SSD hard drive into a rear drive bay	35
9.6.1	Removing a hard drive from the rear drive bay	35
9.6.2	Installing a hard drive into a rear hard drive carrier	36
9.6.3	Installing a hard drive into a rear drive bay	37
9.7	Replacing the DVD ROM drive	37
9.8	Replacing the front port panel	37
9.9	Installing the motherboard	38
9.10	Installing expansion cards	38
9.11	Installing the air shroud	38
9.12	Replacing a system fan	39
9.13	Replacing the power supply	40
9.14	Monitoring the system	41
9.15	Installing Video Recording Manager locally	42
9.16	Service and repair	42

# 1 Safety information

Observe the safety notes in this chapter.

## 1.1 Safety message explanation

**Warning!**

Indicates a hazardous situation which, if not avoided, could result in death or serious injury.

**Caution!**

Indicates a hazardous situation which, if not avoided, could result in minor or moderate injury.

**Notice!**

Indicates a situation which, if not avoided, could result in damage to the equipment or environment, or data loss.

## 1.2 Safety precautions

Follow these rules to ensure general safety:

- Keep the area around the system clean and free of clutter.
- Place the chassis top cover and any system components that have been removed away from the system on a table so that they won't accidentally be stepped on.
- While working on the system, do not wear loose clothing such as neckties and unbuttoned shirt sleeves, which can come into contact with electrical circuits or be pulled into a cooling fan.
- Remove any jewelry or metal objects from your body, which are excellent metal conductors that can create short circuits and harm you if they come into contact with printed circuit boards or areas where power is present.
- After accessing the inside of the system, close the system back up and secure it to the rack unit after ensuring that all connections have been made.
- The system is heavy when fully loaded. When lifting the system, two people at either end should lift slowly with their feet spread out to distribute the weight. Always keep your back straight and lift with your legs.

**Caution!**

Installation should only be performed by qualified service personnel in accordance with applicable local codes.

**Caution!**

The Low Voltage power supply unit must comply with EN/UL 60950. The power supply must be a SELV-LPS unit or a SELV - Class 2 unit (Safety Extra Low Voltage - Limited Power Source).

**Warning!**

Interruption of mains supply:

Voltage is applied as soon as the mains plug is inserted into the mains socket.

However, for devices with a mains switch, the device is only ready for operation when the mains switch (ON/OFF) is in the ON position. When the mains plug is pulled out of the socket, the supply of power to the device is completely interrupted.

**Warning!**

Removing the housing:

To avoid electric shock, the housing must only be removed by qualified service personnel.

Before removing the housing, the plug must always be removed from the mains socket and remain disconnected while the housing is removed. Servicing must only be carried out by qualified service personnel. The user must not carry out any repairs.

**Warning!**

Power cable and AC adapter:

When installing the product, use the provided or designated connection cables, power cables and AC adaptors. Using any other cables and adaptors could cause a malfunction or a fire.

Electrical Appliance and Material Safety Law prohibits the use of UL or CSA-certified cables (that have UL/CSA shown on the code) for any other electrical devices.

**Warning!**

Lithium battery:

Batteries that have been inserted wrongly can cause an explosion. Always replace empty batteries with batteries of the same type or a similar type recommended by the manufacturer. Handle used batteries carefully. Do not damage the battery in any way. A damaged battery may release hazardous materials into the environment.

Dispose of empty batteries according to the manufacturer's instructions.

**Warning!**

Handling of lead solder materials used in this product may expose you to lead, a chemical known to the State of California to cause birth defects and other reproductive harm.

**Notice!**

Electrostatically sensitive device:

To avoid electrostatic discharges, the CMOS/MOSFET protection measures must be carried out correctly.

When handling electrostatically sensitive printed circuits, grounded anti-static wrist bands must be worn and the ESD safety precautions observed.

**Notice!**

Installation should only be carried out by qualified customer service personnel in accordance with the applicable electrical regulations.

### 1.3

## Important safety instructions

Read, follow, and retain for future reference all of the following safety instructions. Follow all warnings before operating the device.

- Clean only with a dry cloth. Do not use liquid cleaners or aerosol cleaners.

- Do not install device near any heat sources such as radiators, heaters, stoves, or other equipment (including amplifiers) that produce heat.
- Never spill liquid of any kind on the device.
- Take precautions to protect the device from power and lightning surges.
- Unless qualified, do not attempt to service a damaged device yourself. Refer all servicing to qualified service personnel.
- Install in accordance with the manufacturer's instructions in accordance with applicable local codes.
- Use only attachments/accessories specified by the manufacturer.
- Protect all connection cables from possible damage, particularly at connection points.
- Do not defeat the safety purpose of a polarized or ground-type plug.
- Permanently connected devices must have an external, readily operable mains plug or all-pole mains switch in accordance with installation rules.
- Pluggable devices must have an easily accessible socket-outlet installed near the equipment.
- Unplug the unit from the outlet before cleaning. Follow any instructions provided with the unit.
- Any openings in the unit enclosure are provided for ventilation to prevent overheating and ensure reliable operation. Do not block or cover these openings.
- Do not place the unit in an enclosure unless proper ventilation is provided, or the manufacturer's instructions have been adhered to.
- Install the unit only in a dry, weather-protected location.
- Do not use this unit near water, for example near a bathtub, washbowl, sink, laundry basket, in a damp or wet basement, near a swimming pool, in an outdoor installation, or in any area classified as a wet location.
- To reduce the risk of fire or electrical shock, do not expose this unit to rain or moisture.
- Never push objects of any kind into this unit through openings as they may touch dangerous voltage points or short-out parts that could result in a fire or electrical shock.
- Power supply cords should be routed so that they are not likely to be walked on or pinched by items placed upon or against them, paying particular attention to cords and plugs, convenience receptacles, and the point where they exit from the appliance.
- Operate the unit only from the type of power source indicated on the label. Use only the power supply provided or power supply units with UL approval and a power output according to LPS or NEC Class 2.
- Do not open or remove the cover to service this unit yourself. Opening or removing covers may expose you to dangerous voltage or other hazards. Refer all servicing to qualified service personnel.
- Be sure the service technician uses replacement parts specified by the manufacturer. Unauthorized substitutions could void the warranty and cause fire, electrical shock, or other hazards.
- Safety checks should be performed upon completion of service or repairs to the unit to ensure proper operating condition.
- Observe the relevant electrical engineering regulations.
- When installing in a switch cabinet, ensure that the unit and the power supply units have sufficient grounding.
- Connect the unit to an earthed mains socket.
- Use proper CMOS/MOS-FET handling precautions to avoid electrostatic discharge (ESD).
- For protection of the device, the branch circuit protection must be secured with a maximum fuse rating of 16 A. This must be in accordance with *NEC800 (CEC Section 60)*.

- Disconnect the power before moving the unit. Move the unit with care. Excessive force or shock may damage the unit and the hard disk drives.
- All the input/output ports are Safety Extra Low Voltage (SELV) circuits. SELV circuits should only be connected to other SELV circuits.
- If safe operation of the unit cannot be ensured, remove it from service and secure it to prevent unauthorized operation. In such cases, have the unit checked by Bosch Security Systems.
- Disconnect power supply and arrange for the device to be serviced by qualified personnel in the following cases, because safe operation is no longer possible:
  - The power cable/plug is damaged.
  - Liquids or foreign bodies have entered the device.
  - The device has been exposed to water or extreme environmental conditions.
  - The device is faulty despite correct installation/operation.
  - The device has fallen from a height, or the housing has been damaged.
  - The device was stored over a long period under adverse conditions.
  - The device performance is noticeably changed.

## 1.4 Electrical safety precautions

Basic electrical safety precautions should be followed to protect you from harm and the system from damage:

- Be aware of the locations of the power on/off switch on the chassis as well as the room's emergency power-off switch, disconnection switch or electrical outlet. If an electrical accident occurs, you can then quickly remove power from the system.
- Do not work alone when working with high voltage components.
- Disconnect the power cables before installing or removing any components from the computer, including the backplane. When disconnecting power, you should first turn off the system and then unplug the power cords from all the power supply modules in the system.
- Disconnect the power cable before installing or removing any cables from the backplane.
- When working around exposed electrical circuits, another person who is familiar with the power-off controls should be nearby to switch off the power if necessary.
- Use only one hand when working with powered-on electrical equipment. This is to avoid making a complete circuit, which will cause electrical shock. Use extreme caution when using metal tools, which can easily damage any electrical components or circuit boards they come into contact with.
- The power supply power cords must include a grounding plug and must be plugged into grounded electrical outlets. The unit has more than one power supply cord. Disconnect both power supply cords before servicing to avoid electrical shock.
- Make sure that the backplane is securely and properly installed on the motherboard to prevent damage to the system due to power shortage.
- Mainboard replaceable soldered-in fuses: Self-resetting PTC (Positive Temperature Coefficient) fuses on the mainboard must be replaced by trained service technicians only. The new fuse must be the same or equivalent as the one replaced. Contact technical support for details and support.



### Caution!

Replaceable batteries

Risk of explosion if battery is replaced by an incorrect type. Dispose of used batteries according to the manufacturer's instructions.



**Caution!**

DVD-ROM Laser: To prevent direct exposure to the laser beam and hazardous radiation exposure, do not open the enclosure or use the unit in any unconventional way.

## 1.5 ESD precautions

**Notice!**

Electrostatic Discharge (ESD) can damage electronic components. To prevent damage to your system, it is important to handle the electronic components very carefully.

Electrostatic Discharge (ESD) is generated by two objects with different electrical charges coming into contact with each other. An electrical discharge is created to neutralize this difference, which can damage electronic components and printed circuit boards. The following measures are generally sufficient to neutralize this difference before contact is made to protect your equipment from ESD:

- Do not use mats designed to decrease electrostatic discharge as protection from electrical shock. Instead, use rubber mats that have been specifically designed as electrical insulators.
- Use a grounded wrist strap designed to prevent static discharge.
- Keep all components and printed circuit boards (PCBs) in their antistatic bags until ready for use.
- Touch a grounded metal object before removing the board from the antistatic bag.
- Do not let components or printed circuit boards come into contact with your clothing, which may retain a charge even if you are wearing a wrist strap.
- Handle a board by its edges only. Do not touch its components, peripheral chips, memory modules or contacts.
- When handling chips or modules, avoid touching their pins.
- Put the mainboard and peripherals back into their antistatic bags when not in use.
- For grounding purposes, make sure your computer chassis provides excellent conductivity between the power supply, the case, the mounting fasteners and the mainboard.

## 1.6 Operating precautions

The chassis cover must be in place when the system is operating to assure proper cooling. Out of warranty damage to the system can occur if this practice is not strictly followed.

**Note:**

Please handle used batteries carefully. Do not damage the battery in any way. A damaged battery may release hazardous materials into the environment. Do not discard a used battery in the garbage or a public landfill. Please comply with the regulations set up by your local hazardous waste management agency to dispose of your used battery properly.

## 1.7 Notices

**Notice!**

This is a **class A** product. In a domestic environment this product may cause radio interference, in which case the user may be required to take adequate measures.

**Notice!**

Video loss is inherent to digital video recording; therefore, Bosch Security Systems cannot be held liable for any damage that results from missing video information.

To minimize the risk of losing information, we recommend multiple, redundant recording systems, and a procedure to back up all analog and digital information.

**Disposal**

Your Bosch product has been developed and manufactured using high-quality materials and components that can be reused.

This symbol means that electronic and electrical devices that have reached the end of their working life must be disposed of separately from household waste.

In the EU, separate collecting systems are already in place for used electrical and electronic products. Please dispose of these devices at your local communal waste collection point or at a recycling center.

**Notice!**

Do not dispose batteries in household waste. Dispose of batteries only at suitable collection points and, in the case of lithium batteries, mask the poles.

**Caution!****Battery replacement - For qualified service personnel only**

A lithium battery is located inside the unit enclosure. To avoid danger of explosion, replace the battery as per instructions. Replace only with the same or equivalent type recommended by the manufacturer. Dispose of the replaced battery in an environmentally friendly way and not with other solid waste. Refer all servicing to qualified service personnel.



Do not place this unit on an unstable stand, tripod, bracket, or mount. The unit may fall, causing serious injury and/or serious damage to the unit.

**Information on sales, delivery, storage, and working life period**

No restrictions or conditions apply for the sale or delivery of this product.

If stored under the specified conditions, the storage period is not restricted.

If used for the specified purpose in compliance with the safety instructions and technical specifications, the working life period of the product is in accordance with normal expectations for this type of product.

**Information on equipment use**

Device is for professional installation only. Operation of the devices is not intended for personal or household use. There are no restrictions to use the device in commercial and industrial areas, except those mentioned in the Safety information.

**1.8****FCC and ICES compliance**

(only for U.S.A. and Canada)

This equipment has been tested and found to comply with the limits for a Class A digital device pursuant to Part 15 of the FCC Rules. These limits are designed to provide reasonable protection against harmful interference when the equipment is operated in a commercial environment. This equipment generates, uses, and can radiate radio frequency energy and, if

not installed and used in accordance with the manufacturer's instruction manual, may cause harmful interference with radio communications. Operation of this equipment in a residential area is likely to cause harmful interference, in which case you will be required to correct the interference at your own expense.

## 2 **About this manual**

This manual is written for professional system integrators and PC technicians. It provides information for the installation and use of the chassis. Installation and maintenance should be performed by experienced and qualified technicians only.

## 3 System overview

### 3.1 Chassis features

The high-performance chassis includes the following features:

- Hard drives  
The chassis features 16 slots for SATA drives. These drives are hot swappable. Once set up correctly, these drives can be removed without powering down the unit. In addition, these drives support SES2 (SATA).
- I/O expansion slots  
Each chassis model includes seven full height, full width PCI expansion slots.
- Peripheral drives  
Each chassis supports one slim DVD-ROM drive. This drive allows you to quickly install or save data.
- Other features  
Other onboard features are included to promote system health. These include various cooling fans, power switches, a reset button, and system status LED indicators.

### 3.2 Chassis components

This chapter describes the most common components included with your chassis. For more information, see the installation instructions detailed later in this manual.

#### 3.2.1 Chassis

The chassis includes 16 hard drive bays and comes with a DVD ROM drive. The chassis supports a 3U backplane.

For empty chassis, the hard drives must be purchased separately. For the latest shipping lists, see the datasheet in the online product catalogue.

#### 3.2.2 Fans

The built-in fans provide 100% cooling redundancy, aided by an adjustable air shroud. The fans are controlled through IPMI (Intelligent Platform Management Interface).

#### 3.2.3 Power supply

The chassis has redundant power supplies. Redundant power supplies are hot-swappable, and can be changed without turning off the system.

Each power supply is auto-switching capable. This enables the power to automatically sense and operate at a 100 V to 240 V input voltage. An amber light will be illuminated on the power supply when the power is off. An illuminated green light indicates that the power supply is operating.

#### 3.2.4 Air shroud

Air shrouds are shields, usually plastic, which conduct the airflow directly to where it is needed to maximize fan efficiency. Always use the air shroud included with your chassis.

#### 3.2.5 Mounting rails

The unit can be placed in a rack for secure storage and use. To set up your rack, follow the step-by-step instructions included in this manual.

### 3.3 System interface

The chassis includes a control panel on the front that houses power buttons and status monitoring lights. The externally accessible hard drives display status lights. The power supply displays status lights visible from the back of the chassis.

**Front view:**

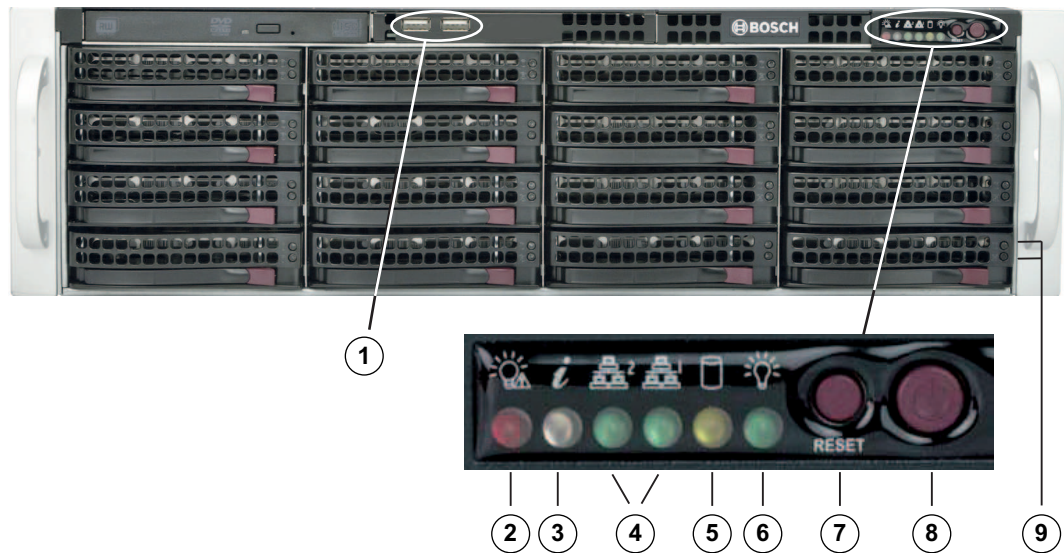

1	2x USB 2.0 ports	2	Power failure
3	Information LED	4	NIC1/NIC2
5	HDD (drive activity)	6	Power
7	Reset	8	Power on/off
9	Drive carrier LEDs (green: access to this drive/red: drive failure)		

**Rear view:**

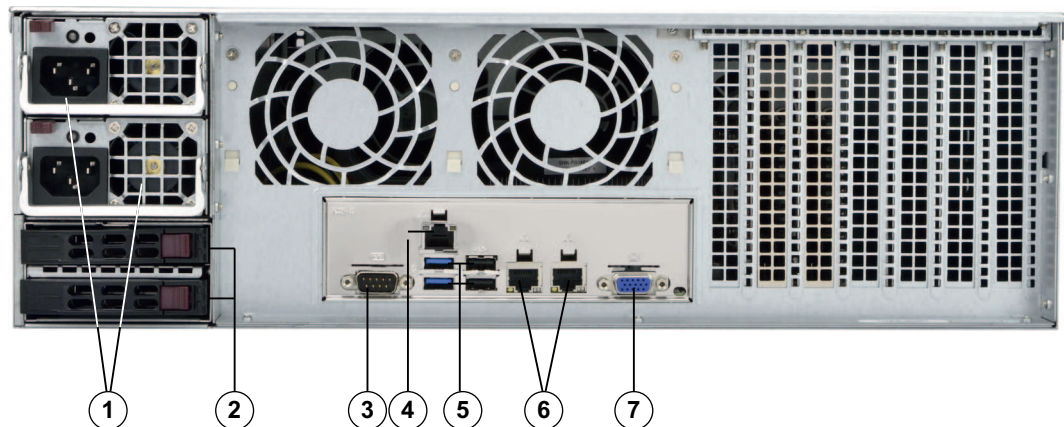



1	2x power supply modules	2	2x redundant SSD drives for operating system (RAID1 mirror)
---	-------------------------	---	---

<b>3</b>	1x serial port	<b>4</b>	1x network port for BMC (Baseboard Management Controller) connection and IPMI (Intelligent Platform Management Interface) monitoring
<b>5</b>	4 USB ports (2x USB 2.0 and 2x USB 3.0)	<b>6</b>	2x network ports for data transmission (teamed) <b>Note:</b> Do not change the teaming mode!
<b>7</b>	1x VGA display output (do not use!)		



### 3.3.1 Control panel buttons

There are two push-buttons located on the front of the chassis. These are (in order from left to right) a reset button and a power on/off button.

- 
**Reset:** The reset button is used to reboot the system.
- 
**Power:** The main power switch is used to apply or remove power from the power supply to the system. Turning off system power with this button removes the main power but keeps standby power supplied to the system. **Therefore, you must unplug system before servicing.**

### 3.3.2 Control panel LEDs



The control panel located on the front of the chassis has LEDs to provide you with critical information related to different parts of the system. This section explains what each LED indicates when illuminated.

- 
**Power failure:** A flashing LED indicates a power failure in the power supply.
- 
 Displays the system status.

System status	Description
Continuously on and red	An overheat condition has occurred. (This may be caused by cable congestion.)
Blinking red (1 Hz)	Fan failure: check for an inoperative fan.
Blinking red (0.25 Hz)	Power failure: check for an inoperative power supply.
Solid blue	Local UID has been activated. Use this function to locate the unit in a rack environment.
Blinking blue (300 msec)	Remote UID has been activated. Use this function to locate the unit from a remote location.

- 
**Overheat/fan fail:** A flashing LED indicates a fan failure.

When continuously on (not flashing) the LED indicates an overheat condition, which may be caused by cables obstructing the airflow in the system or the ambient room temperature being too warm. Check the routing of the cables and make sure all fans are present and operating normally. You should also check to make sure that the chassis covers are installed. Finally, verify that the heat sinks are installed properly. This LED will remain flashing or on as long as the fan failure/overheat condition exists.

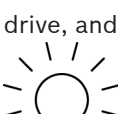
-  **NiC2:** A flashing LED indicates network activity on GLAN2.
-  **NiC1:** A flashing LED indicates network activity on GLAN1.
-  **HDD:** A flashing LED indicates IDE channel activity in the SAS/SATA drive, SCSI drive, and/or DVD-ROM drive activity.
-  **Power:** Indicates power is being supplied to the system's power supply units. This LED should normally be illuminated when the system is operating.

### 3.3.3

#### Drive carrier LEDs

	LED color	Blinking pattern	Behavior for device
<b>ActivityLED</b>	Blue	Solid On	SAS drive installed
	Blue	Blinking	I/O activity
<b>StatusLED</b>	Red	Solid On	Failed drive for SATA/NVMe with RSTe support
	Red	Blinking at 1 Hz	Rebuild drive for SATA with RSTe support
	Red	Blinking with two blinks and one stop at 1 Hz	Hot spare for SATA with RSTe support
	Red	On for five seconds, then off	Power on for SATA with RSTe support
	Red	Blinking at 4 Hz	Identify drive for SATA with RSTe support

### 3.3.4

#### Power supply LEDs

On the rear of the power supply module, an LED displays the status.

- **Solid Green:** When illuminated, indicates that the power supply is on.
- **Solid Amber:** When illuminated, indicates the power supply is plugged in and turned off, or the system is off but in an abnormal state.



- **Blinking Amber:** When blinking, the system power supply temperature has reached 63°C. The system will automatically turn off when the power supply temperature reaches 70°C and restart when the power supply temperature goes below 60°C.

## 4 Rack installation

### 4.1 Unpacking the system

You should inspect the box the chassis was shipped in and note if it was damaged in any way. If the chassis itself shows damage, file a damage claim with the carrier who delivered it and notify the respective Bosch RMA desk.

Due to the weight of the system: After opening the top of the shipping box, one person should stand at either end and lift the disk array out together.

Be sure to read the safety precautions.

### 4.2 Preparing for setup

Read this section in its entirety before you begin the installation procedure outlined in the sections that follow.

#### 4.2.1 Choosing a setup location

- Place the system near at least one grounded power outlet.
- Place the system in a clean, dust-free area that is well ventilated. Avoid areas where heat, electrical noise and electromagnetic fields are generated.
- Leave approximately 25 inches clearance in front of the rack to be able to open the front door completely.
- Leave approximately 30 inches of clearance in the back of the rack to allow for sufficient airflow and ease in servicing.

**Notice!**

This equipment is intended for installation in Restricted Access Location or equivalent.

---

**Notice!**

This product is not suitable for use with visual display work place devices according to §2 of the the German Ordinance for Work with Visual Display Units.

---

#### 4.2.2 Rack precautions

**Warning!**

To prevent bodily injury when mounting or servicing this unit in a rack, you must take special precautions to ensure that the system remains stable. The following guidelines are provided to ensure your safety:

- Ensure that the leveling jacks on the bottom of the rack are fully extended to the floor with the full weight of the rack resting on them.
- This unit should be mounted at the bottom of the rack if it is the only unit in the rack.
- When mounting this unit in a partially filled rack, load the rack from the bottom to the top with the heaviest component at the bottom of the rack.
- In single rack installations, attach stabilizers to the rack.
- If the rack is provided with stabilizing devices, install the stabilizers before mounting or servicing the unit in the rack.
- In multiple rack installations, couple the racks together.
- Always make sure the rack is stable before extending a component from the rack.
- Extend only one component at a time - extending two or more simultaneously may cause the rack to become unstable.

### 4.2.3

#### General system precautions

- Review the electrical and general safety precautions that came with the components you are adding to your chassis.
- Determine the placement of each component in the rack before installing the rails.
- Install the heaviest components on the bottom of the rack first, and then work up.
- Use a regulating uninterruptible power supply (UPS) to protect the system from power surges and voltage spikes if you want to keep your system operating in case of a power failure.
- Allow the hard drives and power supply modules to cool before touching them.
- Always keep the rack's front door and all panels and components on the system closed when not servicing to maintain proper cooling.

**See also:**

- Safety precautions

### 4.2.4

#### Rack mounting considerations

##### Ambient operating temperature

If installed in a closed or multi-unit rack assembly, the ambient operating temperature of the rack environment may be greater than the ambient temperature of the room. Therefore, consideration should be given to installing the equipment in an environment compatible with the manufacturer's maximum rated ambient temperature (T<sub>mra</sub>).

##### Reduced airflow

Equipment should be mounted into a rack so that the amount of airflow required for safe operation is not compromised.

##### Mechanical loading

Equipment should be mounted into a rack so that a hazardous condition does not arise due to uneven mechanical loading.

##### Circuit overloading

Consideration should be given to the connection of the equipment to the power supply circuitry and the effect that any possible overloading of circuits might have on overcurrent protection and power supply wiring. Appropriate consideration of equipment nameplate ratings should be used when addressing this concern.

##### Reliable ground

A reliable ground must be maintained at all times. To ensure this, the rack itself should be grounded. Particular attention should be given to power supply connections other than the direct connections to the branch circuit (i.e. the use of power strips, etc.).

## 4.3

### Rack mounting instructions

This section provides information on installing the chassis into a rack unit. There are a variety of rack units on the market, which may mean the assembly procedure will differ slightly. Also refer to the installation instructions that came with the rack unit you are using.



**Notice!**

This rail will fit a rack between 26.5" and 36.4" deep.

### 4.3.1 Identifying the sections of the rack rails

The chassis package includes two rail assemblies, one designed and labeled for each side of the chassis. Each assembly consists of an inner rail that secures directly to the chassis, and an outer rail that secures to the rack. The outer rail has two sections that can slide and adjust to fit your rack depth.

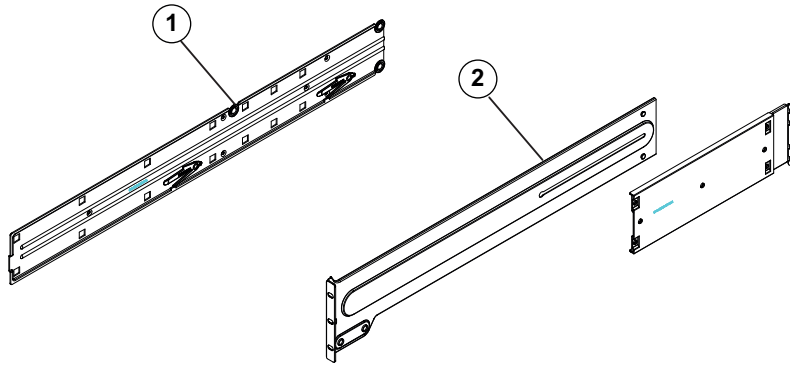

<b>1</b>	Right side inner rail	<b>2</b>	Right side outer rail
----------	-----------------------	----------	-----------------------

### 4.3.2 Separating the sections of the rack rails

The chassis package includes two rail assemblies in the rack mounting kit. Each assembly consists of two sections:

- an inner fixed chassis rail that secures directly to the chassis
- an outer fixed rack rail that secures directly to the rack itself.

#### To separate the inner and outer rails:

1. Locate the rail assembly in the chassis packaging.

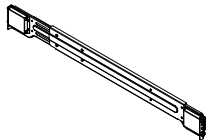

2. Extend the rail assembly by pulling it outward.

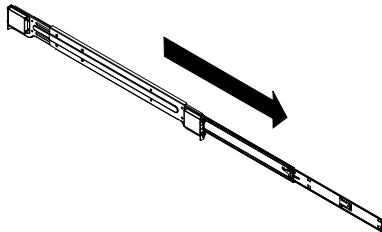

3. Press the quick-release tab.

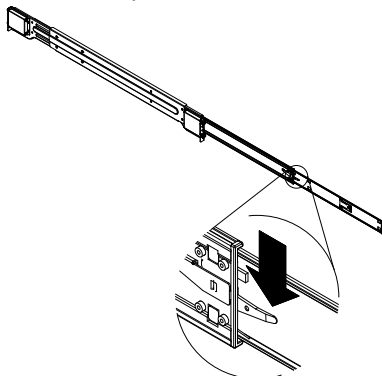

4. Separate the inner rail extension from the outer rail assembly.

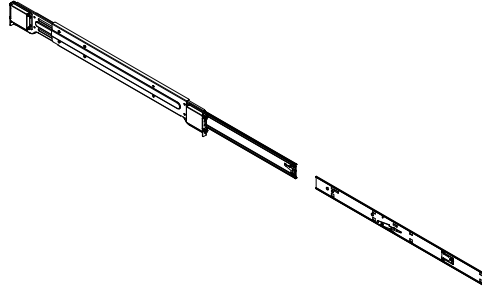

### 4.3.3 Installing the inner rails on the chassis



**Caution!**

Do not pick up the chassis with the front handles. They are designed to pull the system from a rack only.

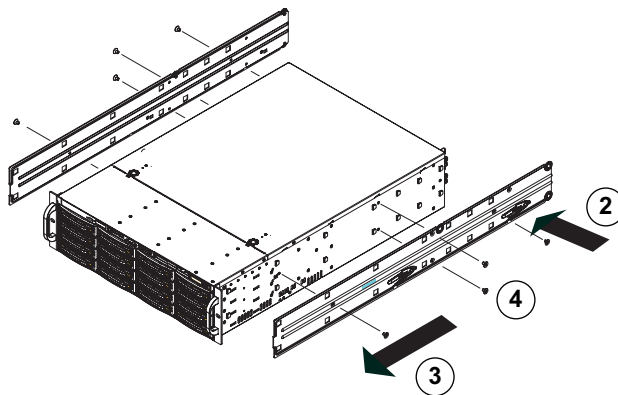

**To install the inner rails:**

1. Identify the left and right inner rails. They are labeled.
2. Place the inner rail firmly against the side of the chassis, aligning the hooks on the side of the chassis with the holes in the inner rail.
3. Slide the inner rail forward toward the front of the chassis until the quick release bracket snaps into place, securing the rail to the chassis.
4. Optionally, you can further secure the inner rail to the chassis with screws.
5. The following picture shows the inner rails installed on the chassis.

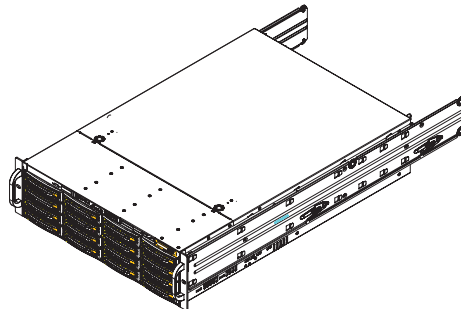

### 4.3.4 Installing the outer rails to the rack

Outer rails attach to the rack and hold the chassis in place.

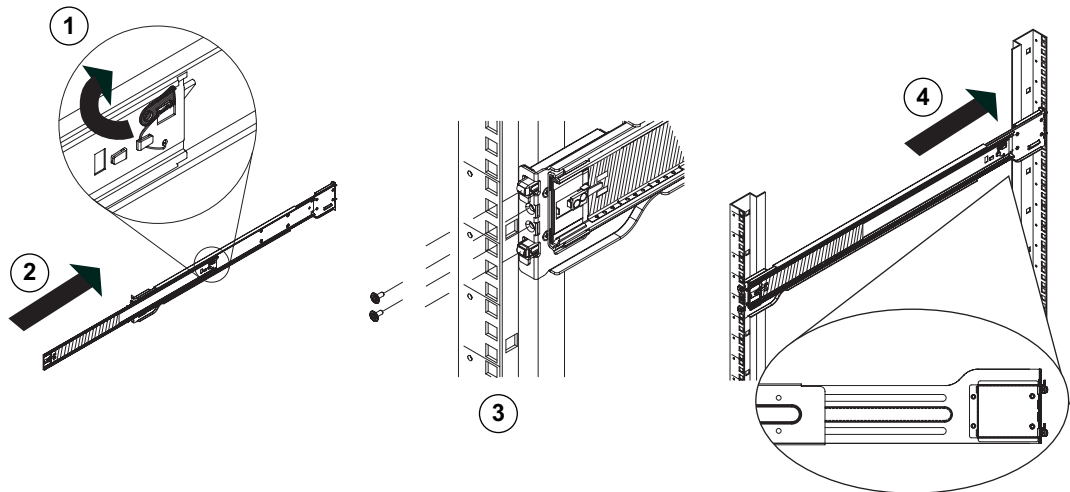

#### To install the outer rails to the rack:

1. Press upward on the locking tab at the rear end of the middle rail.
2. Push the middle rail back into the outer rail.
3. Hang the hooks on the front of the outer rail onto the square holes on the front of the rack. If desired, use screws to secure the outer rails to the rack.
4. Pull out the rear of the outer rail, adjusting the length until it just fits within the posts of the rack.
5. Hang the hooks of the rear section of the outer rail onto the square holes on the rear of the rack. Take care that the proper holes are used so the rails are level. If desired, use screws to secure the rear of the outer rail to the rear of the rack.
6. Repeat for the other outer rail.

### 4.3.5

#### Installing the chassis in the rack



##### Warning!

Stability hazard

Before sliding the unit out for servicing make sure that the rack stabilizing mechanism is in place, or the rack is bolted to the floor. Failure to stabilize the rack can cause the rack to tip over.



##### Warning!

Do not pick up the unit with the front handles. The handles are designed to pull the system from a rack only.



##### Notice!

Mounting the chassis into the rack requires at least two people to support the chassis during installation. Please follow safety recommendations printed on the rails.



##### Notice!

Figures are for illustrative purposes only. Always install chassis into racks from the bottom up.

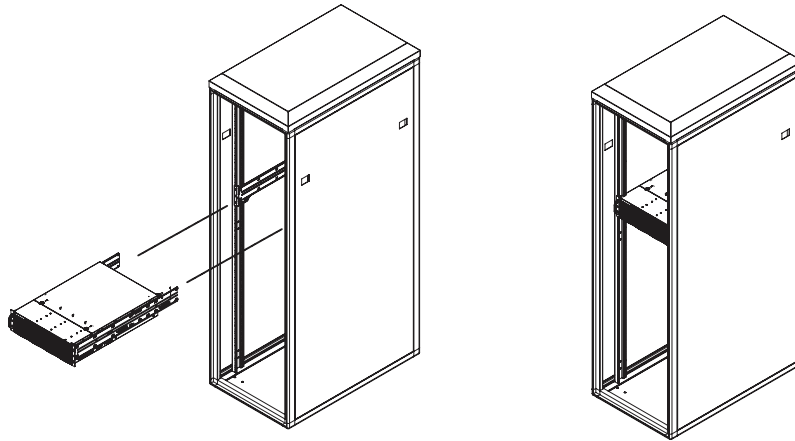

**To install the chassis in the rack:**

1. Align the inner rails of the chassis with the outer rails on the rack.
2. Slide the inner rails into the outer rails, keeping the pressure even on both sides. When the chassis has been pushed completely into the rack, it should click into the locked position.
3. Optionally, screws may be used to hold the front of the chassis to the rack.

**4.3.6 Installing the chassis in a Telco rack**



**Notice!**  
Do not use a two post "Telco" type rack.



**Warning!**  
Stability hazard  
Before sliding the unit out for servicing make sure that the rack stabilizing mechanism is in place, or the rack is bolted to the floor. Failure to stabilize the rack can cause the rack to tip over.



**Warning!**  
Do not pick up the unit with the front handles. The handles are designed to pull the system from a rack only.



**Notice!**  
Mounting the chassis into the rack requires at least two people to support the chassis during installation. Please follow safety recommendations printed on the rails.



**Notice!**  
Figures are for illustrative purposes only. Always install chassis into racks from the bottom up.

To install the chassis into a Telco type rack, use two L-shaped brackets on either side of the chassis (four in total). First, determine how far the chassis will extend out the front of the rack. Larger chassis should be positioned to balance the weight between front and back. If a

bezel is included on the chassis, remove it. Then attach the two front brackets to each side of the chassis, then the two rear brackets positioned with just enough space to accommodate the width of the Telco rack. Finish by sliding the chassis into the rack and tightening the brackets to the rack.

## 4.4 Turning on the system

### To turn on the system:

1. Plug the power cord from the power supply unit into a high-quality power strip that offers protection from electrical noise and power surges. We recommended using an uninterruptible power supply (UPS).
2. Press the power button on the control panel to turn on the system.



## 5 System Setup – first Steps

### 5.1 Introduction

The DIVAR IP 6000 systems are based on Windows Storage Server 2012 R2 operating system. Windows Storage Server 2012 R2 systems provide a user interface for initial server configuration, unified storage appliance management, simplified setup and storage management, and support for Microsoft iSCSI Software Target.

It is specially tuned to provide optimal performance for network-attached storage. Windows Storage Server 2012 R2 operating system provides significant enhancements in storage management scenarios, as well as integration of storage appliance management components and functionality.

This chapter is valid for DIVAR IP 6000 3U models that come with pre-installed hard drives. The operating system of empty units loaded with third party hard drives will start normally, but the added hard drives must be configured with the RAID utility prior to initial software setup.

#### See also

- RAID setup, page 27

### 5.2 Setup instruction

By default the virtual network adapter (the two physical NIC ports are teamed by default) is configured to obtain a valid network address from a DHCP server in the local network. If there is no DHCP server in the network, the system will use the following network settings:

- IP address: 192.168.0.200
- Subnet mask: 255.255.255.0
- User: BVRAdmin
- Password: WSS4Bosch

### 5.3 Setting the IP address

The default IP address can be changed using:

- Microsoft Utility Server Manager program
- or
- IP Helper tool



#### Notice!

Changing the network settings using the IP Helper tool is only possible if the default system password is still unchanged.



#### Notice!

We strongly recommend that you change the password of the administrative BVRAdmin user account after setting the IP address.

#### Microsoft Utility Server Manager program

To change the IP address using Microsoft Utility Server Manager program:

- ▶ Open the Microsoft Utility Server Manager and follow the instructions on the screen to configure the network interface cards (NICs).

#### IP Helper tool

The IP Helper tool is available for download as follows:

- in the online catalog on the DIVAR IP 6000 product page
- under <http://mydivar.com>
- under <http://downloadstore.boschsecurity.com/>

To start the IP Helper tool:

1. Double-click `iphelper.exe`.
2. A dialog box opens that displays all IP devices with their IP addresses located in the network. Search for the devices whose network settings you want change.
3. Change the IP address.

## 5.4 Standard system configuration

The system is delivered with the fully configured iSCSI target and pre-configured LUNs.

The default target name is TGO and holds all of the iSCSI LUNs.

The naming convention for the LUNs is VHDxx.vhdx where <xx> ranges from 01 up to <n> depending on the system used. The default setup allows every iSCSI Initiator (iSCSI host) to connect to the system.

The system comes with iSCSI Target Service enabled.



### **Notice!**

On empty systems you must set up the iSCSI target and the iSCSI LUNs of the drives manually after initial RAID configuration.

---

## 6 RAID setup

If you have added third party hard drives to empty units, you must configure the hard drives using the RAID setup utility. The RAID utility is pre-installed on the system.

**Notice!**

The RAID setup process is not necessary for units with pre-installed hard drives. These units are delivered with a default configuration.

---

To configure the hard drive (creating a new virtual drive):

1. Turn on the unit and log on as user BVRAdmin. The default screen is displayed.
2. Double-click the **MegaRAID Storage Manager** icon on the screen.
3. Select the local machine and log on using the BVRAdmin credentials.
4. Click **Create Virtual Drive**, then click **simple mode**.
5. Select **RAID level 5** and follow the steps in the **Virtual Drive** wizard.
6. Enter the virtual drive properties.
7. Under **Write Policy**, click **Always Write Back**.

**Notice!**

Before you can store video recordings on the drive, you must perform a basic setup using the video software configuration tool, for example, Configuration Manager or Bosch VMS Configuration Client.

---

## 7 Additional software and documentation

Software for configuration of hardware and software is available on the online product catalogue.

**Documentation and software for Bosch Security Systems products can be found in the online product catalogue as follows:**

- ▶ Open any browser > enter [www.boschsecurity.com](http://www.boschsecurity.com) > select your region and your country > start a search for your product > select the product in the search results to show the existing files.

## 8 OSS licenses

This chapter provides an overview on used Open Source Licenses in DIVAR IP 6000. The license packages are either used completely or only some parts within a package are used.

### 8.1 MIT - iniparser

component: iniparser  
url: <https://github.com/ndevilla/iniparser/>  
type: MIT

Copyright (c) 2000-2011 by Nicolas Devillard.  
MIT License

Permission is hereby granted, free of charge, to any person obtaining a copy of this software and associated documentation files (the "Software"), to deal in the Software without restriction, including without limitation the rights to use, copy, modify, merge, publish, distribute, sublicense, and/or sell copies of the Software, and to permit persons to whom the Software is furnished to do so, subject to the following conditions:

The above copyright notice and this permission notice shall be included in all copies or substantial portions of the Software.

THE SOFTWARE IS PROVIDED "AS IS", WITHOUT WARRANTY OF ANY KIND, EXPRESS OR IMPLIED, INCLUDING BUT NOT LIMITED TO THE WARRANTIES OF MERCHANTABILITY, FITNESS FOR A PARTICULAR PURPOSE AND NONINFRINGEMENT. IN NO EVENT SHALL THE AUTHORS OR COPYRIGHT HOLDERS BE LIABLE FOR ANY CLAIM, DAMAGES OR OTHER LIABILITY, WHETHER IN AN ACTION OF CONTRACT, TORT OR OTHERWISE, ARISING FROM, OUT OF OR IN CONNECTION WITH THE SOFTWARE OR THE USE OR OTHER DEALINGS IN THE SOFTWARE.

### 8.2 MS-PL - MSDN Library

component: MSDN Library  
url: <http://msdn.microsoft.com/en-us/library/>  
type: MS-PL

Microsoft Limited Public License

This license governs use of code marked as "sample" or "example" available on this web site without a license agreement, as provided under the section above titled "NOTICE SPECIFIC TO SOFTWARE AVAILABLE ON THIS WEB SITE." If you use such code (the "software"), you accept this license. If you do not accept the license, do not use the software.

#### 1. Definitions

The terms "reproduce," "reproduction," "derivative works," and "distribution" have the same meaning here as under U.S. copyright law.

A "contribution" is the original software, or any additions or changes to the software.

A "contributor" is any person that distributes its contribution under this license.

"Licensed patents" are a contributor's patent claims that read directly on its contribution.

#### 2. Grant of Rights

(A) Copyright Grant - Subject to the terms of this license, including the license conditions and limitations in section 3, each contributor grants you a non-exclusive, worldwide, royalty-free copyright license to reproduce its contribution, prepare derivative works of its contribution, and distribute its contribution or any derivative works that you create.

(B) Patent Grant - Subject to the terms of this license, including the license conditions and limitations in section 3, each contributor grants you a non-exclusive, worldwide, royalty-free license under its licensed patents to make, have made, use, sell, offer for sale, import, and/or otherwise dispose of its contribution in the software or derivative works of the contribution in the software.

### 3. Conditions and Limitations

(A) No Trademark License- This license does not grant you rights to use any contributors' name, logo, or trademarks.

(B) If you bring a patent claim against any contributor over patents that you claim are infringed by the software, your patent license from such contributor to the software ends automatically.

(C) If you distribute any portion of the software, you must retain all copyright, patent, trademark, and attribution notices that are present in the software.

(D) If you distribute any portion of the software in source code form, you may do so only under this license by including a complete copy of this license with your distribution. If you distribute any portion of the software in compiled or object code form, you may only do so under a license that complies with this license.

(E) The software is licensed "as-is." You bear the risk of using it. The contributors give no express warranties, guarantees or conditions. You may have additional consumer rights under your local laws which this license cannot change. To the extent permitted under your local laws, the contributors exclude the implied warranties of merchantability, fitness for a particular purpose and non-infringement.

(F) Platform Limitation - The licenses granted in sections 2(A) and 2(B) extend only to the software or derivative works that you create that run on a Microsoft Windows operating system product.

## 8.3 NTP License - NTP Project

component: NTP Project

url: <http://support.ntp.org/bin/view/Main/WebHome>

type: NTP License

\*\*\*\*\*

Copyright (c) University of Delaware 1992-2012 \*

Permission to use, copy, modify, and distribute this software and its documentation for any purpose with or without fee is hereby granted, provided that the above copyright notice appears in all copies and that both the copyright notice and this permission notice appear in supporting documentation, and that the name University of Delaware not be used in advertising or publicity pertaining to distribution of the software without specific, written prior permission. The University of Delaware makes no representations about the suitability this software for any purpose. It is provided "as is" without express or implied warranty.

---

## 9 Maintenance

This chapter covers the steps required to install components and perform maintenance on the chassis.

**Notice!**

Installation should only be carried out by qualified customer service personnel in accordance with the applicable electrical regulations.

**Caution!**

Review the warnings and precautions listed in the manual before setting up or servicing this chassis.

---

### 9.1 Replacement components

Although not frequently, you may need replacement parts for your system. To ensure the highest level of professional service and technical support, you must register the systems according to the instructions available as part of the shipment as well as online from the Bosch product catalog.

### 9.2 Removing power from the system

Before performing some setup or maintenance tasks, use the following procedure to ensure that power has been removed from the system.

To remove the power:

1. Shut down the system.
2. Remove the power cords from the power supplies.
3. Disconnect the cord from the power strip or wall outlet.

## 9.3 Removing the chassis cover

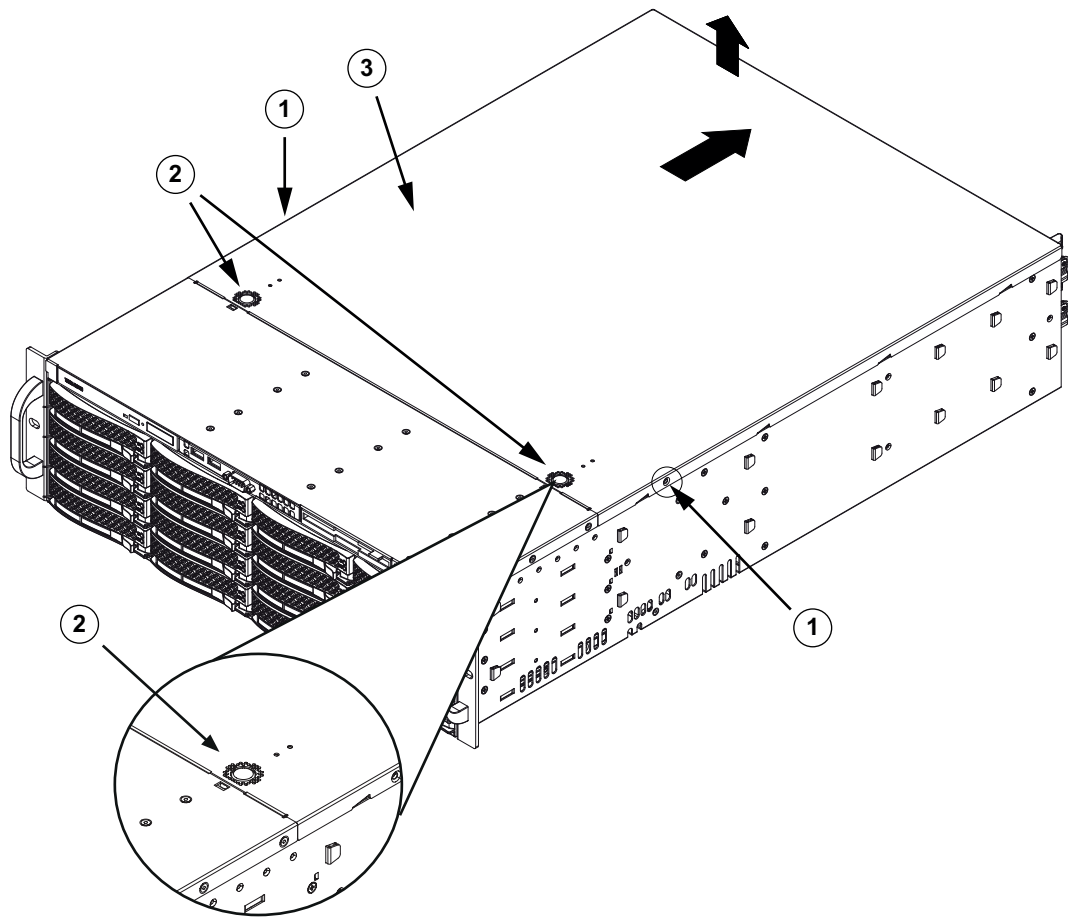

<b>1</b>	Fixing screws	<b>3</b>	Chassis cover
<b>2</b>	Release tabs		

### To remove the chassis cover:

1. Disconnect the power supply, lay the chassis on a flat surface.
2. Remove the two screws on each side of the cover, which secure the cover to the chassis.
3. Press the release tabs to remove the cover from the locked position. Press both tabs at the same time.
4. Once the top cover is released from the locked position, slide the cover toward the rear of the chassis and lift the cover off the chassis.



### Notice!

Except for short periods of time, do NOT operate the server without the cover in place. The chassis cover must be in place to allow proper airflow and prevent overheating.

## 9.4 Installing a SATA hard drive

This chapter describes the removing and installing of SATA hard drives.

### 9.4.1 Removing a hard drive from the chassis

The hard drives are mounted in hard drive carriers to simplify their installation and removal from the chassis. These hard drive carriers also help promote proper airflow for the hard drive bays.



The unit features hot-swappable hard drives which can be removed without powering down the system.

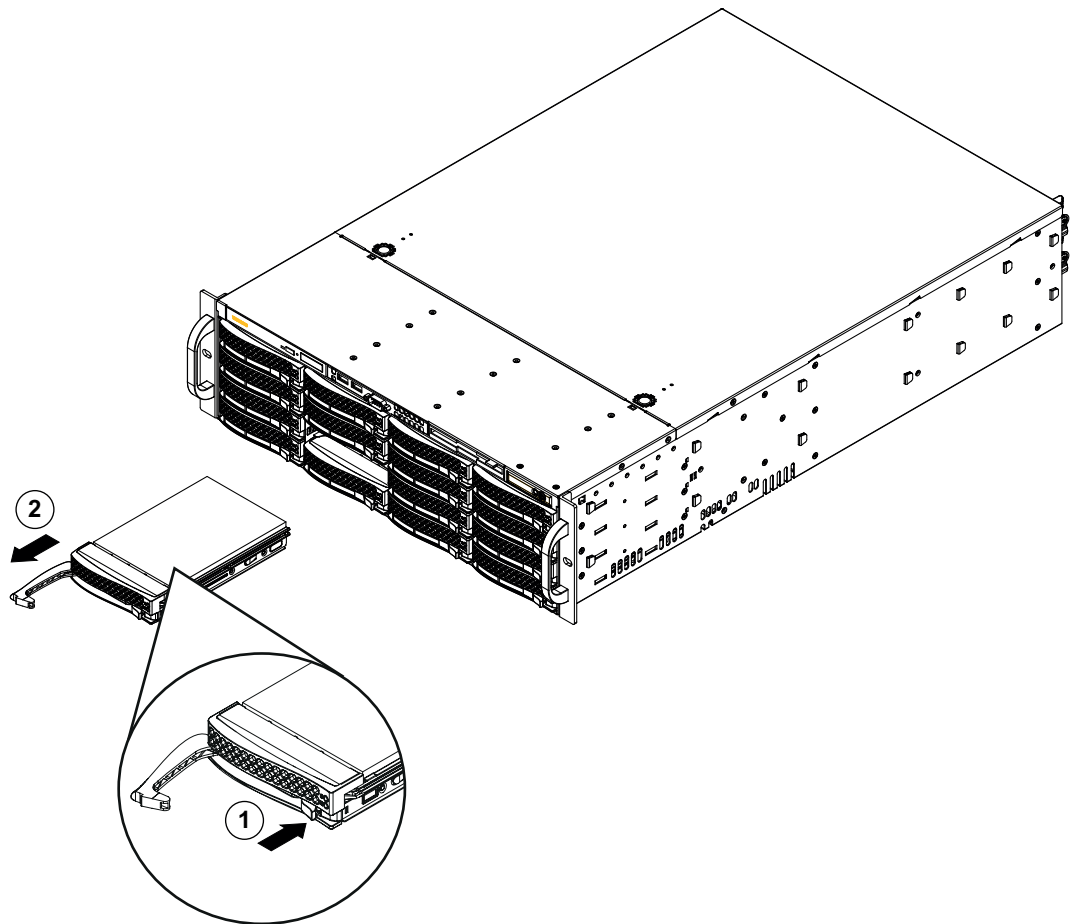

<b>1</b>	Release button	<b>2</b>	Hard drive carrier handle
----------	----------------	----------	---------------------------

**To remove a hard drive from the chassis:**

1. Press the release button to the right of the hard drive carrier. This extends the hard drive carrier handle.
2. Use the handle to pull the drive out of the chassis.



**Notice!**

Except for short periods of time (swapping hard drives), do not operate the unit with the hard drives removed from the bays.

**9.4.2**

**Installing a hard drive into a hard drive carrier**

The hard drives are mounted in hard drive carriers.

**To install a hard drive into a hard drive carrier:**

1. Remove the screws securing the dummy drive to the hard drive carrier.

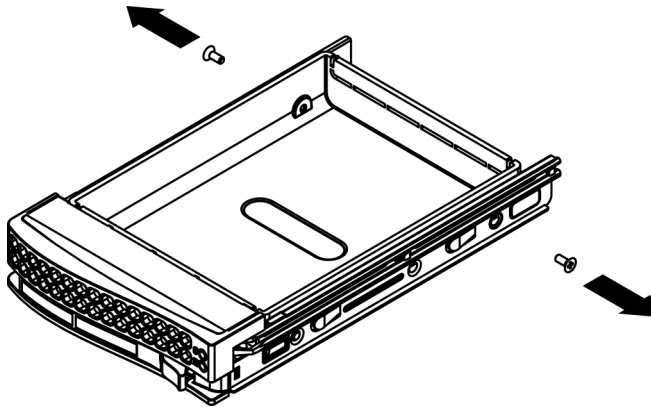

2. Remove the dummy drive from the hard drive carrier and place the hard drive carrier on a flat surface.
3. Slide a new hard drive into the hard drive carrier with the printed circuit board side facing down.
4. Align the mounting holes in both, the hard drive carrier and the hard drive.
5. Secure the hard drive to the hard drive carrier using six screws.

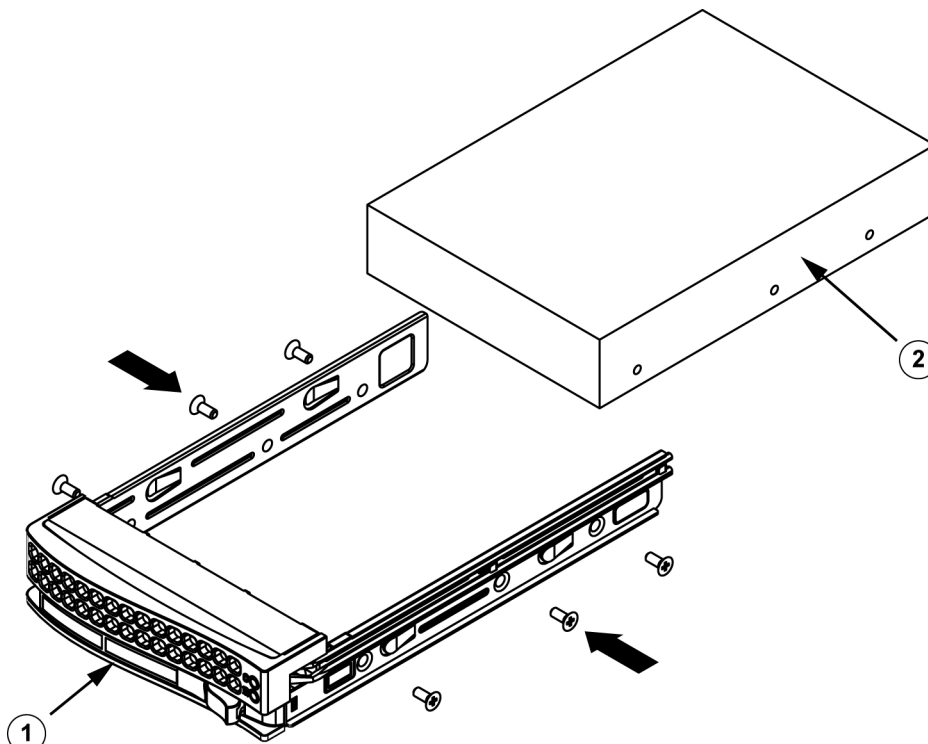

1	Hard drive carrier	2	SATA hard drive
---	--------------------	---	-----------------

6. Replace the hard drive carrier into the chassis bay. Make sure that the hard drive carrier handle is completely closed.



**Notice!**

We recommend using the respective Bosch hard disk drives. The hard disk drives as one of the critical component are carefully selected by Bosch based on available failure rates. HDD – not delivered from Bosch – are not supported. Information on supported HDDs can be found in the datasheet in the Bosch Online Product Catalog.

**See also**

- *Installing a hard drive into a front drive bay, page 35*

**9.4.3****Installing a hard drive into a front drive bay****To install a hard drive into a hard drive bay:**

1. Push against the upper part of the hard drive handle.
2. Push the hard drive horizontally into the hard drive bay, orienting the hard drive so that the release button is on the right.
3. Push the hard drive carrier into the bay until the handle retracts and the hard drive clicks into the locked position.

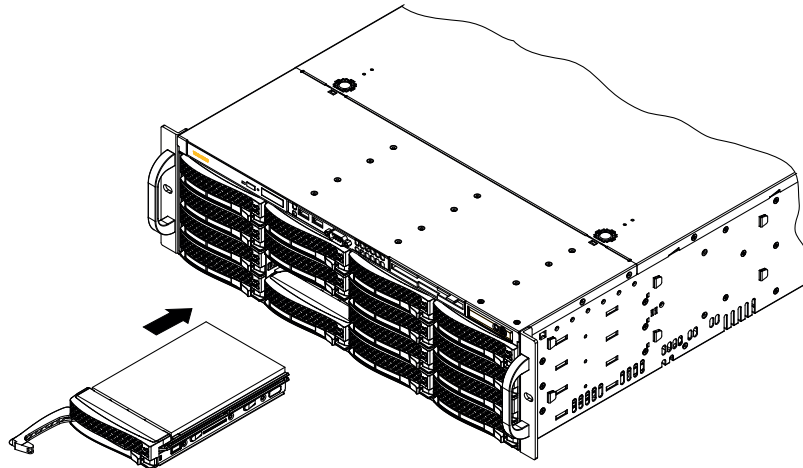
**9.5****Identifying a faulty SSD drive**

The system provides tools for hard drive monitoring that are pre-installed on the system. Use the Intel Rapid Storage tool to identify a faulty SSD drive, if the RAID 1 mirror that holds the operation system partition is running in degraded mode.

To identify and replace SSD drives:

1. Turn on the unit and log on as user BVRAdmin. The default screen is displayed.
2. Double-click the **Intel Rapid Storage** icon on the screen.
3. Check the status of the listed SSD drives and note the port numbers.
  - SATA port 0: refers to the SSD located in the upper tray
  - SATA port 1: refers to the SSD located in the lower tray
4. After you have identified the faulty SSD drive, open the corresponding tray on the back of the system and replace the SSD drive.

**See also**

- *Installing a SSD hard drive into a rear drive bay, page 35*

**9.6****Installing a SSD hard drive into a rear drive bay**

This chapter describes the removing and installing of SSD hard drives on the rear side of the chassis.

**9.6.1****Removing a hard drive from the rear drive bay**

The unit features two hot-swappable hard drives on the rear side which can be removed without powering down the system.

The hard drives are mounted in hard drive carriers to simplify their installation and removal from the chassis. These hard drive carriers also help promote proper airflow for the hard drive bays.

**To remove a hard drive from the chassis:**

1. Press the release button to the right of the hard drive carrier. This extends the hard drive carrier handle.
2. Use the handle to pull the drive out of the chassis.

**Notice!**

Except for short periods of time (swapping hard drives), do not operate the unit with the hard drives removed from the bays.

**9.6.2****Installing a hard drive into a rear hard drive carrier**

The hard drives are mounted in hard drive carriers.

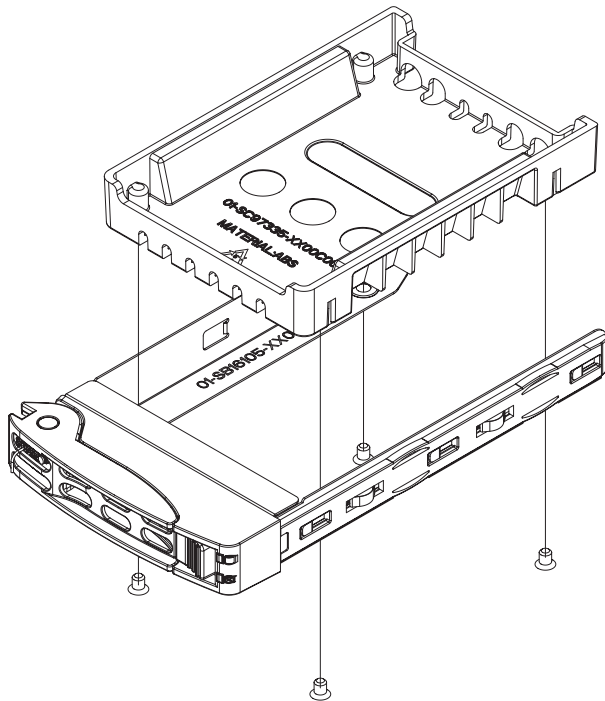
**To install a hard drive into the rear hard drive carrier:**

1. Remove the screws securing the dummy drive to the hard drive carrier.
2. Remove the dummy drive from the hard drive carrier.
3. Insert a hard drive into the hard drive carrier with the printed circuit board side facing down and the connector end toward the rear of the carrier.
4. Align the mounting holes in both, the hard drive carrier and the hard drive.
 

**Note:** There are mounting holes in the hard drive carrier marked "SAS" or "SATA" to aid in correct installation.
5. Secure the hard drive to the hard drive carrier with four screws. Use the four M3 flat-head screws included in the hard disk bag of your accessory box.
 

**Note:** To secure the hard drive, you cannot reuse the screws that are used to secure the dummy drive to the tray.

**Notice!**

We recommend using the respective Bosch hard disk drives. The hard disk drives as one of the critical component are carefully selected by Bosch based on available failure rates. HDD – not delivered from Bosch – are not supported. Information on supported HDDs can be found in the datasheet in the Bosch Online Product Catalog.

### 9.6.3 Installing a hard drive into a rear drive bay

**To install a hard drive into a hard drive bay:**

1. Push against the upper part of the hard drive handle.
2. Push the hard drive horizontally into the hard drive bay, orienting the hard drive so that the release button is on the right.
3. Push the hard drive carrier into the bay until the handle retracts and the hard drive clicks into the locked position.

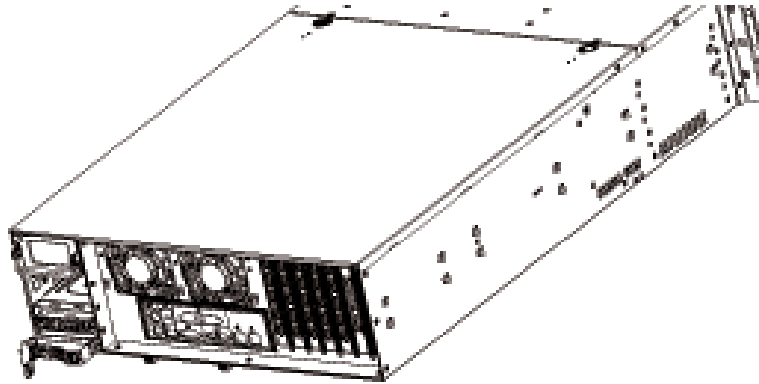

### 9.7 Replacing the DVD ROM drive

The unit includes a DVD-ROM which is pre-installed.



<b>1</b>	DVD-ROM	<b>2</b>	Front port panel
----------	---------	----------	------------------

**To replace the DVD-ROM drive:**

1. Turn off the unit and if necessary, remove the unit from the rack.
2. Remove the chassis cover.
3. Unplug the drives power and data cables from the motherboard and/or backplane.
4. Locate the locking tab at the rear (on the left when viewed from front) of the DVD-ROM drive. Push the tab toward the drive and push the drive unit out the front of the chassis.
5. Insert the new drive unit in the slot until the tab locks in place.
6. Reconnect the data and power cables.
7. Replace the chassis cover. replace the unit in the rack, if necessary, then turn on the system.

### 9.8 Replacing the front port panel

If you must install a new or replace a damaged front port panel, observe the following instructions.



<b>1</b>	DVD-ROM	<b>2</b>	Front port panel
----------	---------	----------	------------------

**To replace the front port panel:**

1. Turn off and unplug the unit.
2. Remove the chassis cover.
3. Disconnect the power and data cables from the front port panel to other chassis components including the motherboard and backplane.
4. Remove the old port panel by depressing the release tab, then pulling the unit out of the chassis.
5. Insert the new front port panel unit in the slot until the tab locks into place.
6. Connect the data and power cables to the backplane and motherboard.

## 9.9 Installing the motherboard

Motherboard problems will be handled by trained support people only.

## 9.10 Installing expansion cards

The chassis includes seven PCI slots for full-height, full-length expansion cards, for example the graphic card or sound card.

**To install expansion cards:**

1. Turn off the system, lay the chassis on a flat surface, then open the chassis cover.
2. Remove the screw holding the chassis slot shield in place.
3. Insert the expansion card into the card slot, while aligning the expansion card shield with the slot in the rear of the chassis.
4. Secure the expansion card shield to the chassis using the screw previously removed.

## 9.11 Installing the air shroud

The air shroud does not require screws for its installation.

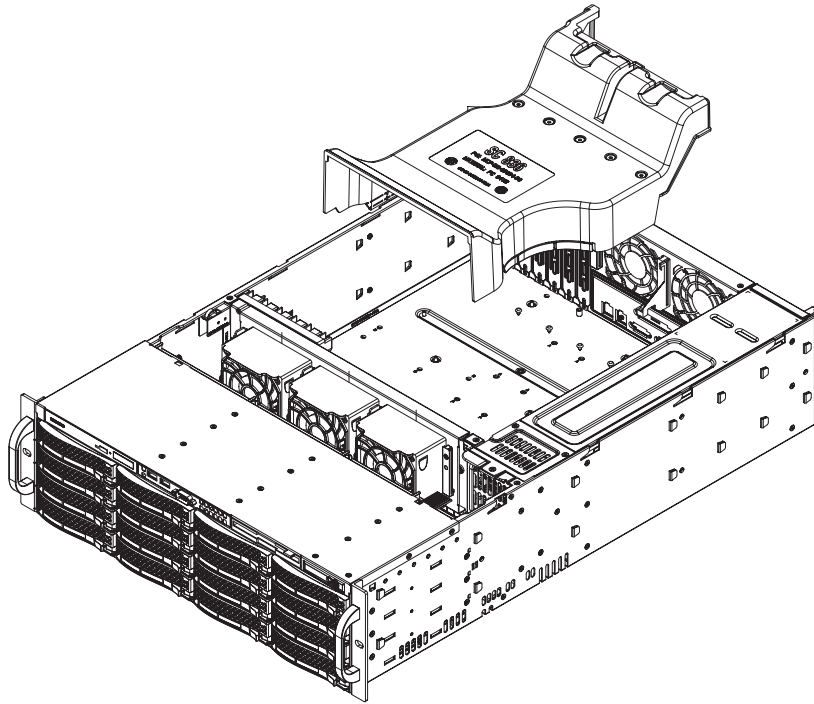
**To install the air shroud:**

1. Make sure that your air shroud matches your chassis model.
2. Turn off the system and remove the cover.
3. Place the air shroud in the chassis. The air shroud fits behind the two fans closest to the power supply.
4. After checking the fit of the air shroud, remove any break-away tabs necessary to ensure a proper fit with the serverboard.

**To check the air flow:**

1. Make sure there are no objects to obstruct airflow in and out of the chassis. In addition, if you are using a front bezel, make sure the bezel's filter is replaced periodically.
2. Do not operate the system without drives or drive trays in the drive bays. Use only recommended material.
3. Make sure no wires or foreign objects obstruct air flow through the chassis. Pull all excess cabling out of the airflow path or use shorter cables. The control panel LEDs inform you about system status.

## 9.12

### Replacing a system fan

**Caution!**

Hazardous moving parts

Keep away from moving fan blades.

The fans might still be turning when you remove the fan assembly from the chassis. Keep fingers, screwdrivers, and other objects away from the openings in the fan assembly's housing.

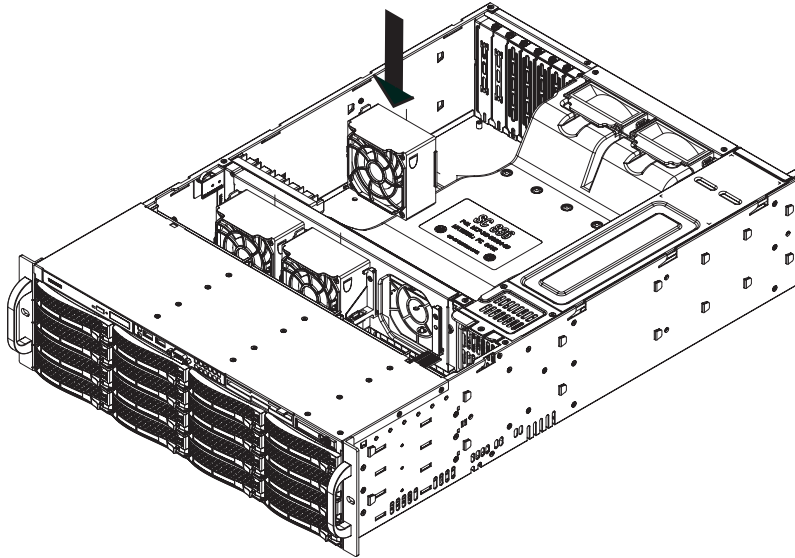

#### To replace a system fan:

1. If necessary, open the chassis while the power is running to determine which fan has failed.  
**Note:** Never run the system for an extended period of time with the chassis open.
2. Turn off the power to the system and unplug the power cord from the outlet.
3. Remove the failed fan's power cord from the motherboard.
4. Press the fan release tab to lift the failed fan from the chassis and pull it completely from the chassis.

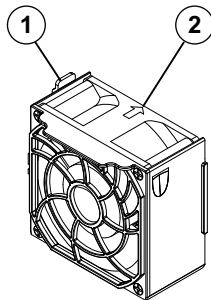

- 1 – Release tab  
 2 – Airflow direction indicator

5. Place the new fan into the vacant space in the housing while making sure the arrows on the top of the fan (indicating air direction) point in the same direction as the arrows on the other fans.
6. Reconnect the power cord, turn on the system and make sure that the fan is working properly before replacing the chassis cover.
7. Replace the chassis cover.

## 9.13

### Replacing the power supply

The chassis has a redundant power supply. Redundant power supplies are hot-swappable, and can be changed without turning off the system.

Replacement units can be ordered directly from Bosch RMA desk.



#### Warning!

Redundant power supplies

This unit might have more than one power supply connection. To de-energize the unit, remove all connections.



**LED status:**

- Amber lighted LED: The power supply is off.
- Green lighted LED: The power supply is operating.

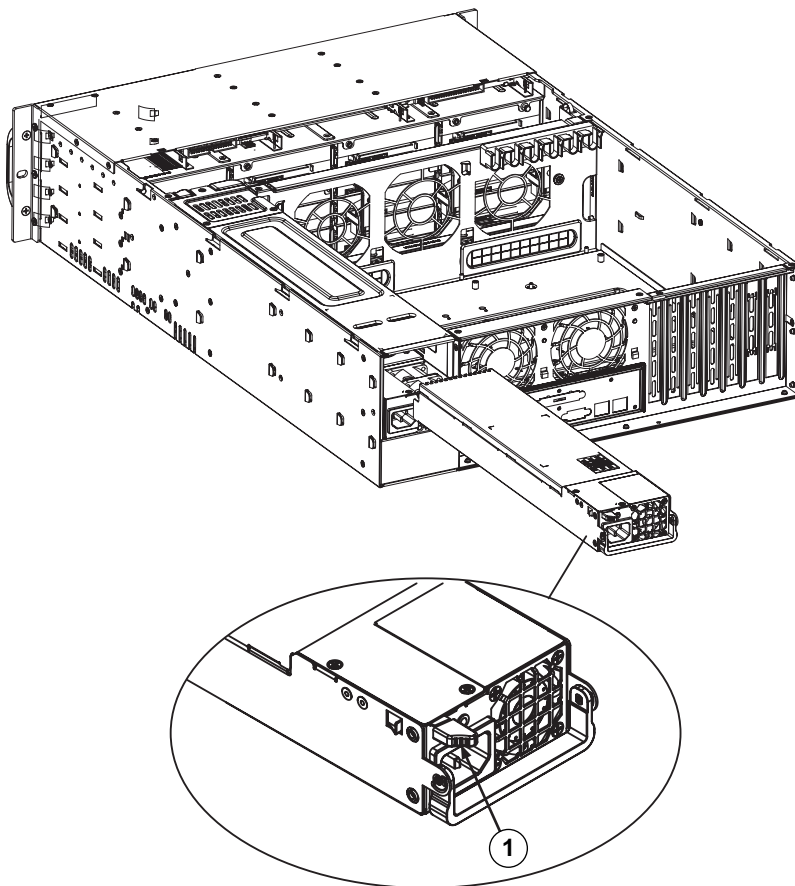

<b>1</b>	Release tab
----------	-------------

**To replace the power supply:**

1. You can leave the unit running and remove only one power supply if your chassis includes a redundant power supply.
2. Unplug the AC power cord of the failed power supply.
3. Push the release tab (on the back of the power supply) as illustrated.
4. Pull the power supply out using the handle provided.
5. Replace the failed power module with the same model.
6. Push the new power supply module into the power bay until you hear a click.
7. Plug the AC power cord back into the module and turn on the unit.

**9.14****Monitoring the system**

The system provides tools for health monitoring.

To activate the monitoring functionality:

1. Turn on the unit and log on as user BVRAdmin. The default screen is displayed.
2. Double-click the **SuperDoctor 5** service icon on the screen.
3. Log on to the web interface using the following default credentials:  
User Name: ADMIN  
Password: ADMIN
4. Click the **Configuration** tab, then click **Password Settings** and change the default password.

5. Click the **Configuration** tab, then click **Alert Configuration**.
6. Activate the **SNMP Trap** feature and specify the IP address of the receiver for SNMP traps.

## 9.15 Installing Video Recording Manager locally

To install the Video Recording Manager program locally:

1. Turn on the unit and log on as user BVRAdmin. The default screen is displayed.
2. Double-click the **Download Video Recording Manager** icon on the screen.
3. Download and install the Video Recording Manager installation package.

**Note:** After installation Video Recording Manager is pre-licensed with 64 channels.



### Notice!

For detailed information using the program, refer to the Video Recording Manager documentation.

## 9.16 Service and repair

The storage system is backed by a 3-year warranty. Issues will be handled according to Bosch Service and Support guidelines.

The storage equipment is shipped with an original manufacturer Service and Support agreement.

Bosch RMA Desk is the Single Point of Contact in case of failure but the Service and Support obligations are fulfilled by the manufacturer or a partner.

In order to enable the manufacturer's Service and Support organization to fulfill the defined Service Levels, the system must be re-registered. Otherwise, the defined service level cannot be provided but only best effort.

A description what information is required and where to send is included in each shipment as paper work. The description is also electronically available in the Bosch online product catalogue.

### Request for RMA

Please request an RMA for failed parts from one of the following Bosch RMA contacts.

- **RMA Contact AMEC**  
 Bosch ST, RMA Swapstock, 8601 East Cornhusker Hwy, Lincoln, NE 68507 -USA  
 Phone: +1(402)467-6610  
 Fax: n.a.  
 E-mail: repair@us.bosch.com  
 Opening Hours: Monday to Friday, 06:00 – 16:30
- **RMA Desk APR**  
 Robert Bosch (SEA) Pte Ltd, 11 Bishan Street 21, (level 5, from service lift), Singapore 573943  
 Phone: +65 6571 2872  
 Fax: n.a.  
 Email: rmahelpdesk@sg.bosch.com  
 Opening Hours: Monday to Friday, 08:30 – 17:45
- **RMA contact China**  
 Bosch (Zhuhai) Security Systems Co. Ltd. Ji Chang Bei Road 20#, Qingwan Industrial Estate; Sanzao Town, Jinwan District, Zhuhai; P.R. China; Postal Code: 519040  
 Phone: +86 756 7633117 / 121  
 Fax: n.a.  
 Email: customer.service@cn.bosch.com

Opening Hours: Monday to Friday, 08:30 – 17:30

– **RMA Contact EMEA**

Bosch Security Systems, C/o EVI Audio GmbH, Ernst-Heinkel Str. 4, 94315 Straubing,  
GERMANY

Contact person: RA Desk Supervisor

Phone: +49(9421)706-366

Fax: n.a.

E-mail: [rmadesk.stservice@de.bosch.com](mailto:rmadesk.stservice@de.bosch.com)

Opening Hours: Monday to Friday, 07:00 – 18:00





**Bosch Sicherheitssysteme GmbH**

Robert-Bosch-Ring 5

85630 Grasbrunn

Germany

**[www.boschsecurity.com](http://www.boschsecurity.com)**

© Bosch Sicherheitssysteme GmbH, 2016