



**UBX**  
**ULTIMATE LOCKABLE**  
**BALL LOCKER**

**Features:**

- Full-size
- Heavy-duty 1" powder-coated steel tubing
- Two heavy-duty swivel caster wheels
- Two large 8" rear wheels for easy mobility
- Lockable hinged lid
- 45"L x 24"W x 39"H
- Black

**Instructions:**

Take control of your gym storage needs with our full-size Champion Sports Ultimate Ball Locker.

1. Start by attaching the crossbar to the riser with screws. Attach the wheels using the wheel nuts. Figure 1
2. Connect the slatted base bottom ring to the risers with screws. Continue with the round rings next, finishing with the top round ring. Attach the top to the top round ring using the hex bolts and hex nuts. Figure 2



Figure 1

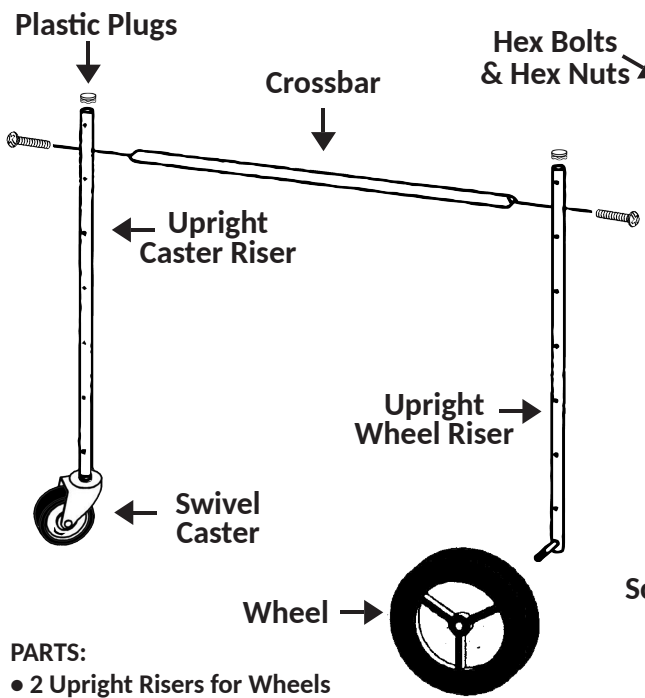
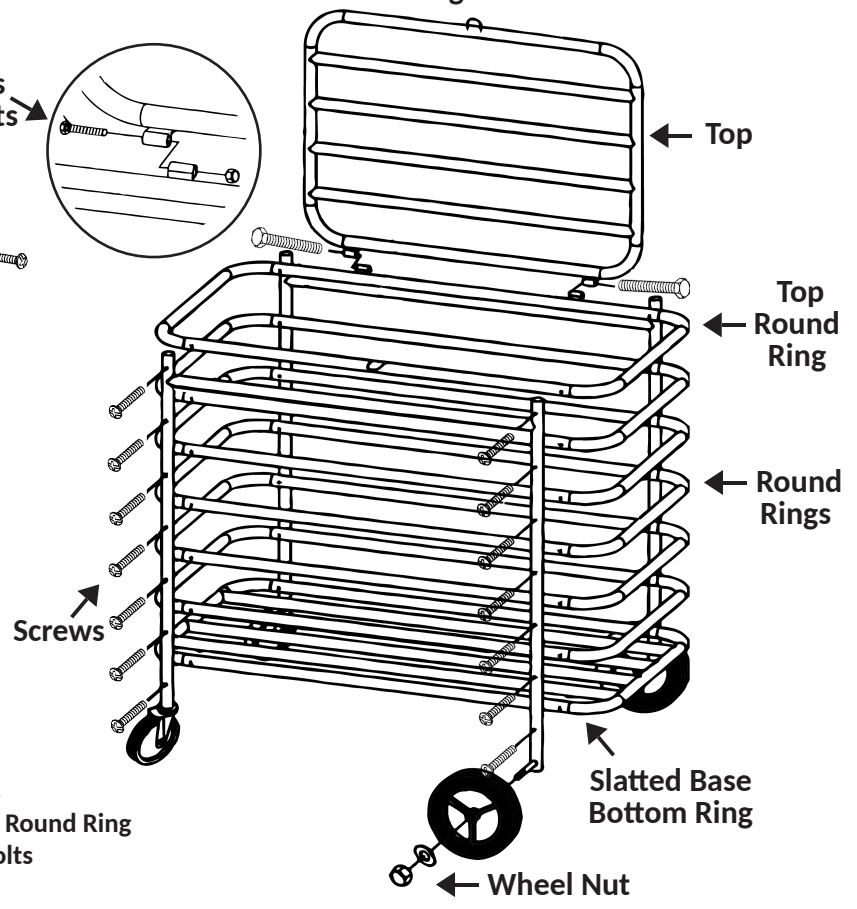

Figure 2



**PARTS:**

- 2 Upright Risers for Wheels
- 2 Wheels
- 2 Wheel Washer & Nuts
- 2 Upright Risers w/Swivel Casters
- 2 Plastic Plugs
- 1 Top
- 1 Top Round Ring
- 2 Crossbars
- 5 Round Rings
- 1 Slatted Base Round Ring
- 2 Large Hex Bolts
- 2 Large Nuts
- 32 Screws
- 28 Screw Nuts