

The lateral add-on blocks are mounted before the module
Monter les additifs latéraux avant le module
Die seitlichen Zusatzteile vor dem Modul einbauen
Montar los aditivos laterales antes del módulo
Montare gli additivi laterali prima del modulo
Montar os aditivos laterais antes do módulo

integral 18

LA1/LB1

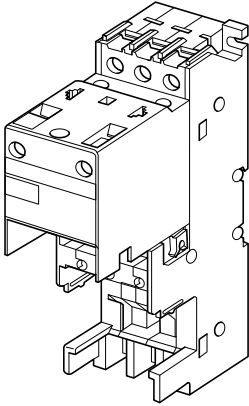

LD1 - LB030.

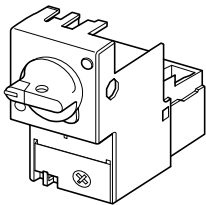
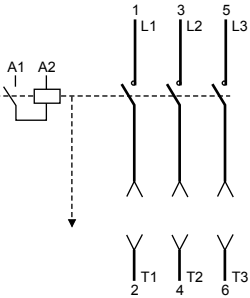

LB1 - LB03P

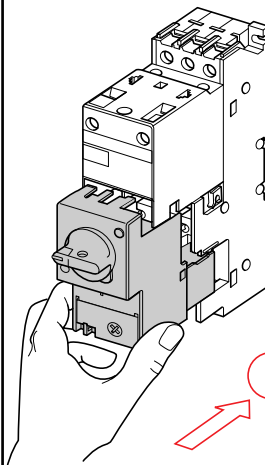
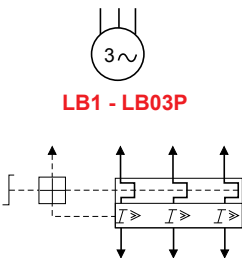

IMPORTANT
Il convient de vérifier à la mise en service et périodiquement, au moins une fois par an, le déclenchement de l'appareil.

IMPORTANT
Once a year at least, we advise during installation and periodically during service, to trip test the unit.

WICHTIG
Es empfiehlt sich, die Inbetriebnahme und das Auslösen in regelmäßigen Abständen mindestens einmal pro Jahr zu überprüfen

IMPORTANTE
Es importante comprobar al arranque y de vez en cuando al menos una vez por año, el lanzamiento del aparato.

IMPORTANTE
Convieni verificare, all'atto della messa in servizio e periodicamente almeno una volta all'anno, l'innesto dell'apparechio

IMPORTANTE
Convém verificar, ao colocar em serviço e periodicamente pelo menos uma vez por ano, o disparo do aparelho

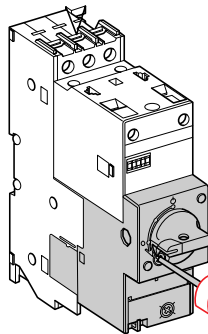

C = 1,1 N.m
C = 10 lb.in

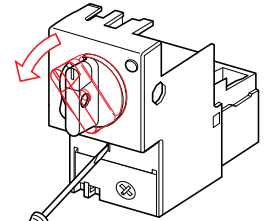
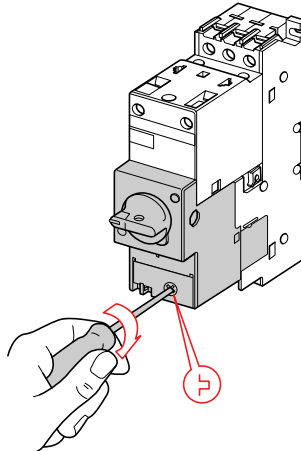

**LD1 - LB030.
+
LB1 - LB03P**

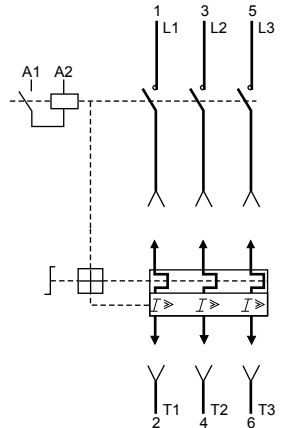

LX1

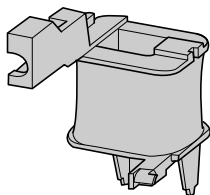

LD1

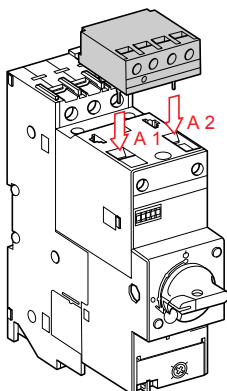
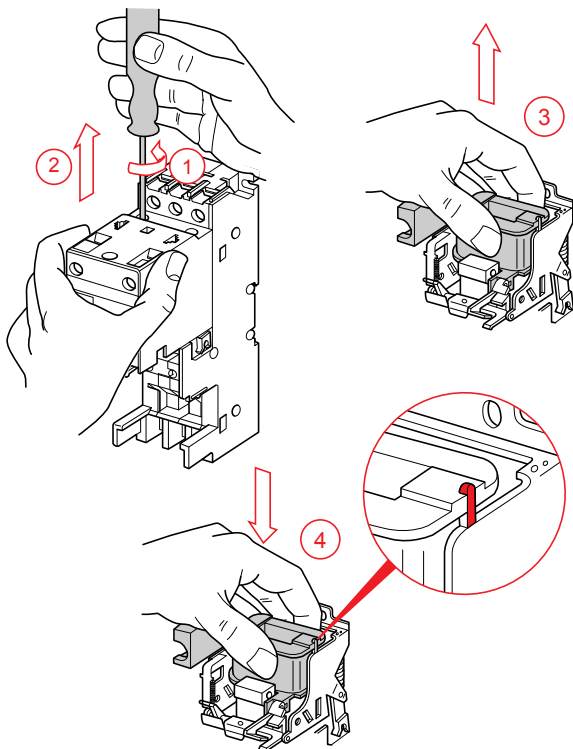
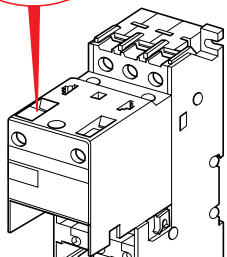

**LA4 DF. / LA4 DW. - LA4 DL
LA4 DM.
LA4 DR. / LA4 DT.**

Modules d'interface
INTERFACE MODULES
INTERFACE-MODULE
MÓDULOS DE INTERFACE
MODULO DE INTERFACCIA
MÓDULOS DE INTERFACE

Modules "AUTO-MAN" "I" "O"
"AUTO-MAN" "I" "O" INPUT MODULE
SCHALTMODUL "HAND-AUS" "I" "O"
MÓDULOS "AUTO-MAN" "I" "O"
MODULO "AUTO-MAN" "I" "O"
MÓDULOS "AUTO-MAN" "I" "O"

Retard à l'excitation ou à la désexcitation bobine
DELAY ON COIL ENERGISATION OR DENERGISATION
VERZÖGERUNGSBLÖCKE ANSPRECH, RÜCKFALLVER ZÖGERT
RITARDO ALL'ECCITAZIONE O ALLA DISECCITAZIONE BOBINA
RETRASO A LA CONEXION O A LA DESCONEXION DE LA BOBINA
ASTRASO NA EXCITAÇÃO OU DESEXCITAÇÃO DA BOBINA

integral 18

LA1/LB1

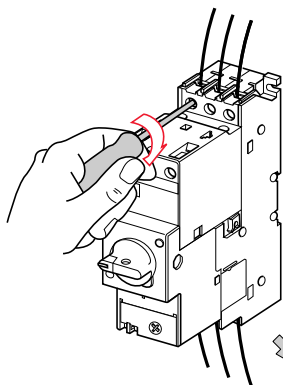

[mm ²]	[mm ²]	[mm ²]	[mm ²]	[mm ²]	[mm ²]	Philips	C N.m	C lb.in
1...6	1...4 + 1...4	1,5...6	1,5...6 + 1,5...6	1,5...6	1,5...6 + 1,5...6	Ø 6	2	1,7
1...2,5 + 1...2,5 LA1-LB	1...2,5 + 1...2,5	1...2,5 + 1...2,5	1...2,5 + 1...2,5	1...2,5	1...2,5 + 1...2,5	Ø 6	2	1,2

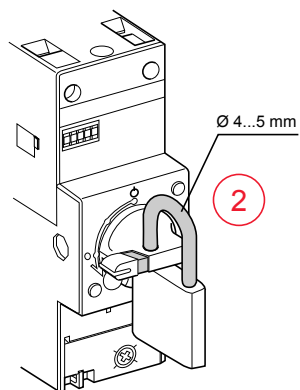
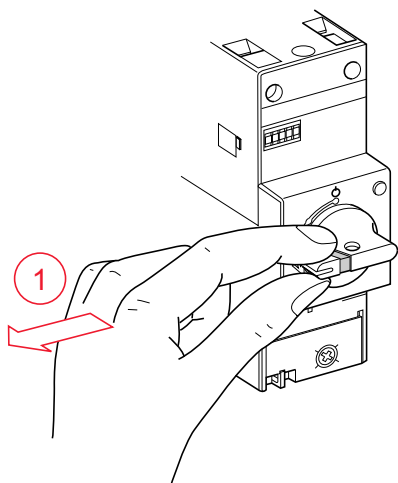
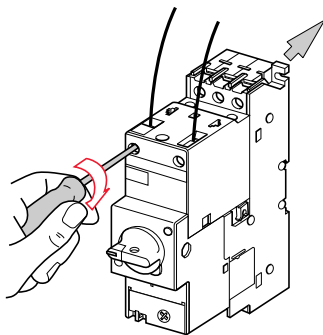

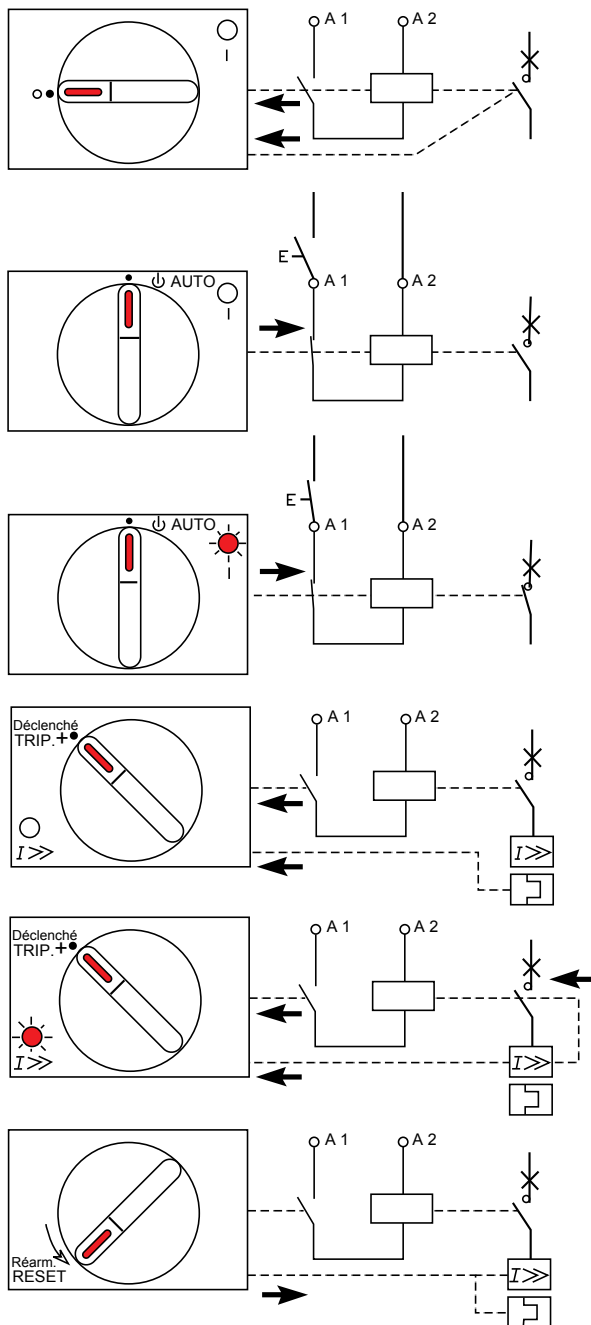

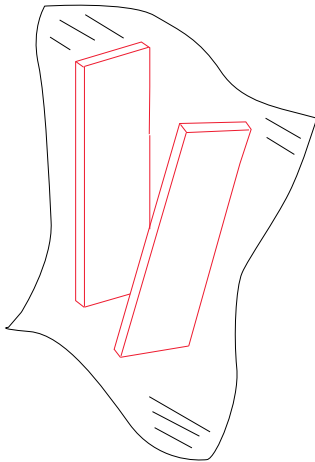

GA1 C6

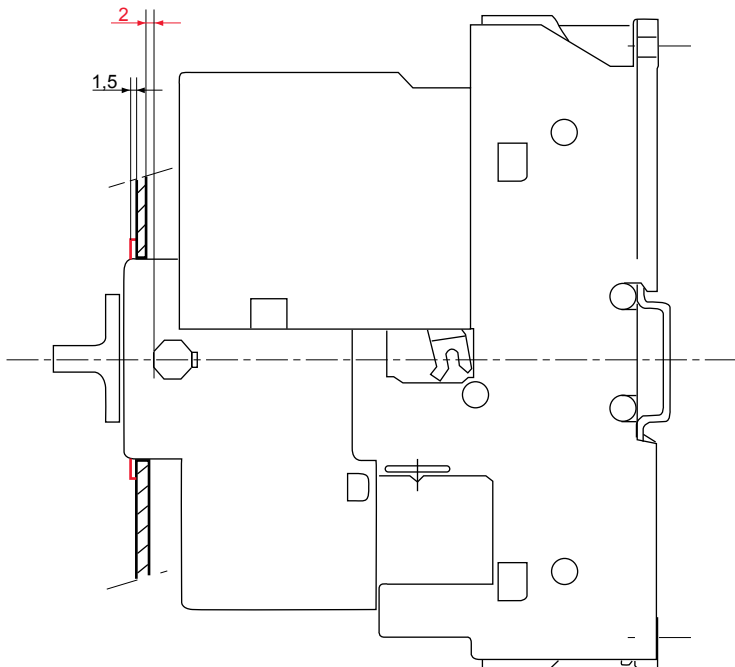
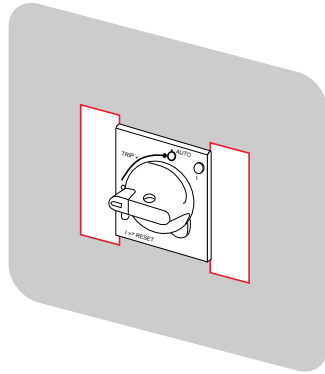

LA9 LB 910

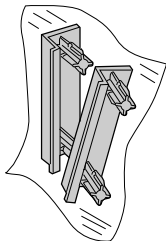

LD1

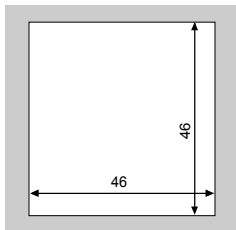

LD1 + 2 (LA1-LB 0●●)

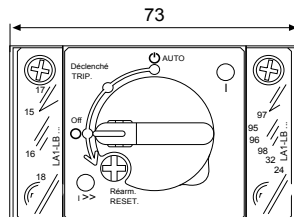

LD1 + 1 (LA1-LB 0●●)

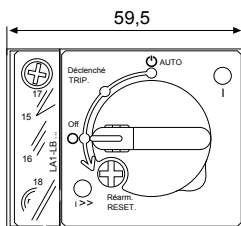

LD1 + 1 (GA1 C6)

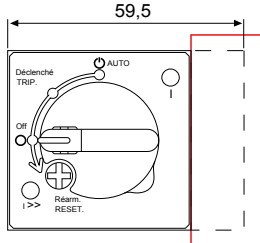

LD1 + 2 (GA1 C6)

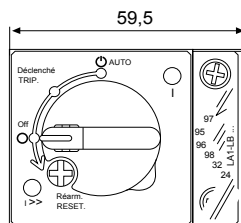
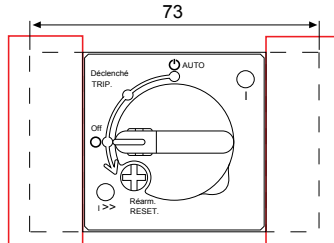

Avertissement

Pour assurer les protections de surcharge, de court-circuit et de défaut de terre, suivre les instructions du fabricant concernant la sélection des protections de surcharge et de court-circuit afin de réduire les risques de feu et de choc électrique.

WARNING

TO MAINTAIN OVERCURRENT, SHORT-CIRCUIT AND GROUND-FAULT PROTECTION, THE MANUFACTURER'S INSTRUCTIONS FOR SELECTION OF OVERLOAD AND SHORT-CIRCUIT PROTECTION MUST BE FOLLOWED TO REDUCE THE RISK OF FIRE OR ELECTRIC SHOCK.

WARNUNG:

UM DIE SCHUTZFUNKTIONEN BEI ÜBERLAST, KURZSCHLUSS UND ERDSCHLUSS ZU GEWÄHRLEISTEN SIND DIE ANGABEN DES HERSTELLERS ZUR AUSWAHL DER ÜBERLAST-UND KURZSCHLUSSSCHUTZES ZUR VERMEIDUNG VON FEUER UND ELEKTRISCHEN SCHLÄGEN ZU BEFOLGEN.

(AVISO)

(PARA DISPONER DE LA PROTECCIÓN CONTRA SOBRECARGAS, CORTOCIRCUITO Y DEFECTO A TIERRA DEBEN SEGUIRSE LAS INSTRUCCIONES DE SELECCIÓN DE PROTECCIONES INDICADAS POR EL FABRICANTE, REDUCIENDO ASÍ, EL RIESGO DE DESCARGA ELÉCTRICA O INCENDIO)

ATTENZIONE

PER RIDURRE IL RISCHIO DI INCENDIO O DI SHOCK ELETTRICO ATTENERSI ALLE ISTRUZIONI DEL COSTRUTTORE RIGUARDANTI LA PROTEZIONE CONTRO LE SOVRACORRENTI, IL CORTO CIRCUITO ED I GUASTI VERSO TERRA.

ATENÇÃO

PARA ASSEGURAR AS PROTECÇÕES CONTRA SOBRECARGAS, CURTO-CIRCUITOS E DEFEITO À TERRA É NECESSÁRIO SEGUIR AS INSTRUÇÕES DO FABRICANTE, RELATIVAS À SELEÇÃO DAS PROTECÇÕES CONTRA SOBRECARGAS E CURTO-CIRCUITOS, DE MANEIRA A REDUZIR OS RISCOS DE INCÊNDIO E DE CHOQUES ELÉTRICOS.

